

**SEWER VALVE LID**

"WATER" TO BE CAST IN COVER WHEN USED ON WATER MAIN OR "SEWER" WHEN USED ON FORCE MAIN

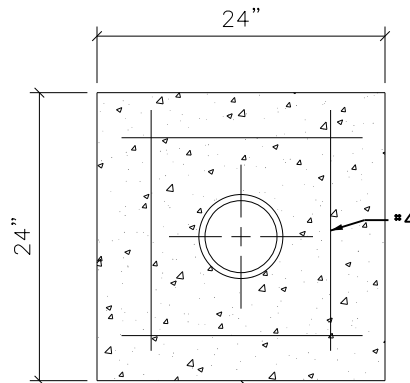

CONCRETE COLLAR  
6" THICK MINIMUM

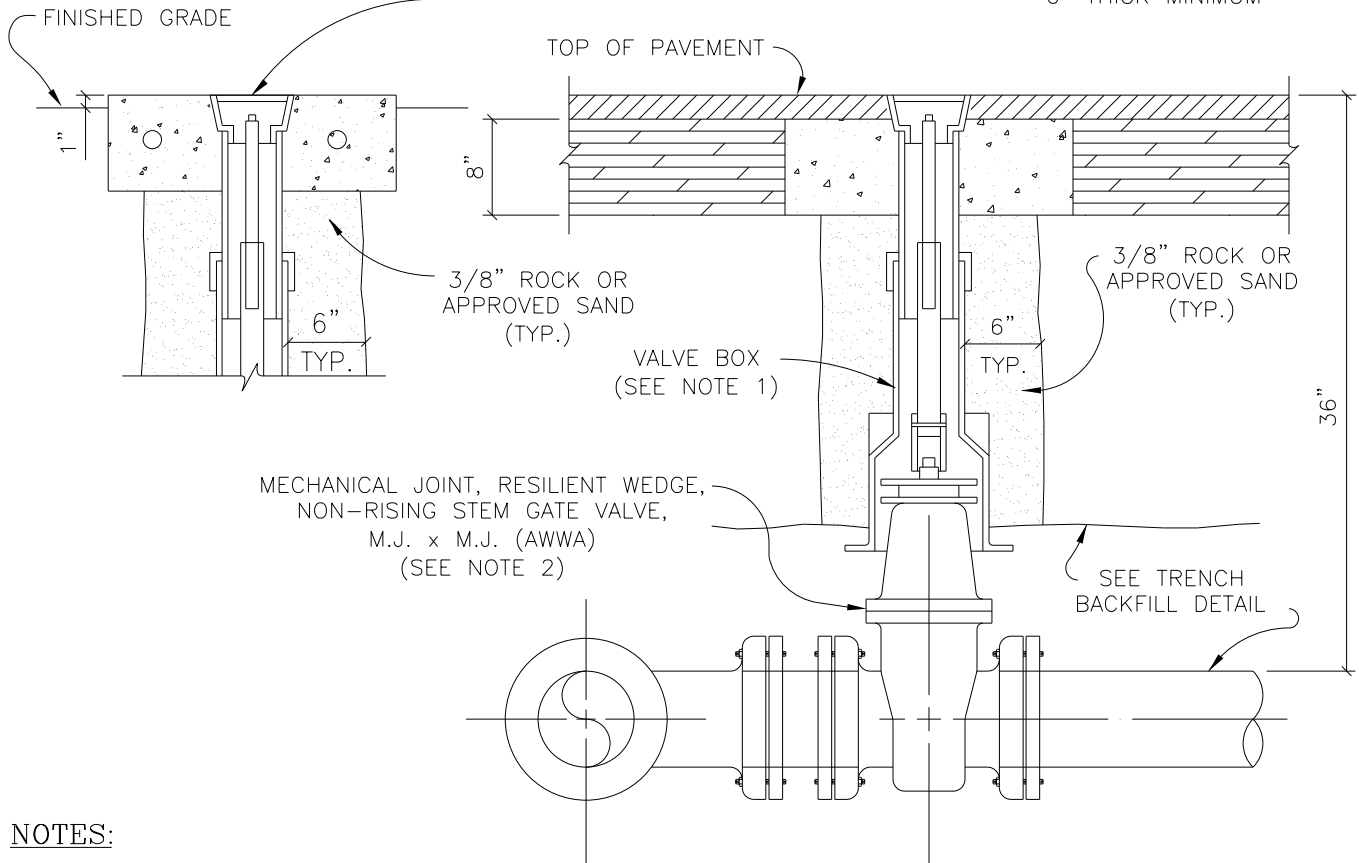

**NOTES:**

1. VALVE BOX SHALL BE DOMESTIC EAST JORDAN IRON WORKS OR APPROVED EQUAL HAVING AN ADJUSTABLE RANGE OF + OR - 6 INCHES FROM INSTALLED FINISH GRADE.
2. ACCEPTABLE GATE VALVES ARE:
  - A. N/A
  - B. MUELLER - 2360 SERIES
  - C. CLOW

SCALE: NOT TO SCALE



**MARBLE FALLS**  
800 THIRD STREET  
MARBLE FALLS, TX 78654  
PH: (830) 693-6737

These documents were prepared by,  
or under the supervision of:

ERIC BELAJ 107148 May 31, 2017  
Engineer's Name PE# Date

  
Engineer's Signature

SECTION

**WATER**

DETAIL NO.

**WT-17**

TITLE

WATER VALVE