

### RIBBON CURB

#### NOTES:

1. ALL WORK AND MATERIAL SHALL CONFORM TO ASTM A615, A615M, C309, AND D1752. BROOM FINISH EXPOSED SURFACE.
2. CONTRACTION JOINT SPACING 10' MAX.
3. EXPANSION JOINTS AS PER STD. ASTM D-1752.

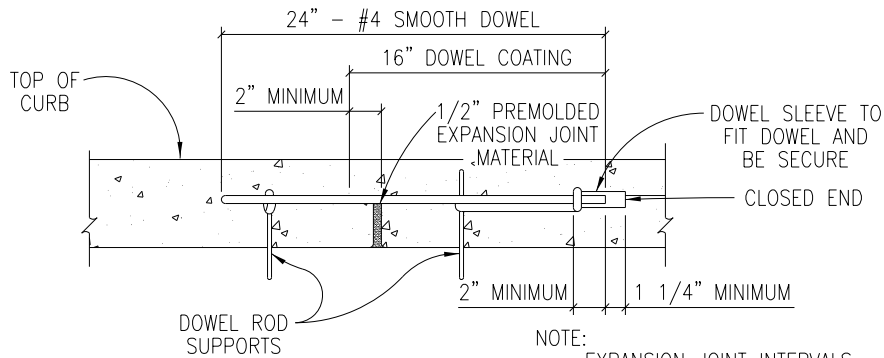

### CURB DOWEL DETAIL

#### NOTES:

1. EXPANSION JOINT INTERVALS NOT TO EXCEED 40'-0".
2. "SCORE" CURB AT 10'-0" INTERVALS.

SCALE: NOT TO SCALE



MARBLE FALLS  
800 THIRD STREET  
MARBLE FALLS, TX 78654  
PH: (830) 693-6737

These documents were prepared by,  
or under the supervision of:

ERIC BELAJ 107148 May 31, 2017  
Engineer's Name PE# Date

  
Engineer's Signature

SECTION

**PAVING**

DETAIL NO.

PV-8

TITLE

RIBBON CURB SECTION