

SECTION A-A

CONNECT ENDS OF THE SUCCESSIVE REINFORCEMENT SHEETS OR ROLLS A MIN. OF 6 TIMES WITH HOG RINGS.

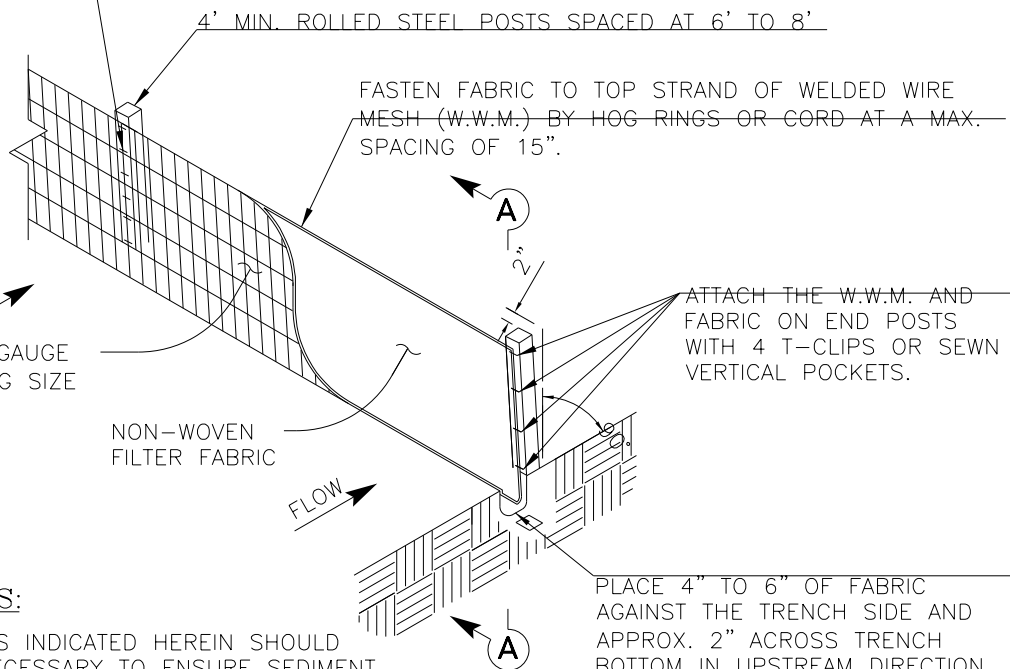

GALV. W.W.M. (12 GAUGE MIN.) MAX. OPENING SIZE SHALL BE 2"X4".

NON-WOVEN FILTER FABRIC

ATTACH THE W.W.M. AND FABRIC ON END POSTS WITH 4 T-CLIPS OR SEWN VERTICAL POCKETS.

PLACE 4" TO 6" OF FABRIC AGAINST THE TRENCH SIDE AND APPROX. 2" ACROSS TRENCH BOTTOM IN UPSTREAM DIRECTION. MIN. TRENCH SIZE SHALL BE 6" SQUARE. BACKFILL AND HAND TAMP.

SILT FENCE NOTES:

1. THE DESIGN DETAILS INDICATED HEREIN SHOULD BE MODIFIED AS NECESSARY TO ENSURE SEDIMENT DOES NOT LEAVE THE PROJECT SITE.

SILT FENCE USAGE GUIDELINES

A SILT FENCE MAY BE CONSTRUCTED NEAR THE DOWNSTREAM PERIMETER OF A DISTURBED AREA ALONG A CONTOUR TO INTERCEPT SEDIMENT FROM OVERLAND RUNOFF.

SCALE: NOT TO SCALE



MARBLE FALLS
 800 THIRD STREET
 MARBLE FALLS, TX 78654
 PH: (830) 693-6737

These documents were prepared by,
 or under the supervision of:

ERIC BELAJ 107148 May 31, 2017
 Engineer's Name PE# Date

[Signature]
 Engineer's Signature

SECTION	EROSION CONTROL
DETAIL NO.	EC-2
TITLE	SILT FENCE