



Standard Details

1st Edition August 2017

ORDINANCE NO. 2017-0-09D



CITY OF
Marble Falls
TEXAS

ORDINANCE NO. 2017-0-09D

AN ORDINANCE OF THE CITY OF MARBLE FALLS AMENDING CHAPTER 7, AND RENAMING SAME TO BUILDING, BUILDING REGULATIONS, AND TECHNICAL CONSTRUCTION STANDARD SPECIFICATIONS AND BY ADDING A NEW ARTICLE XIII, SECTION 7-331, TO ADOPT THE TECHNICAL CONSTRUCTION STANDARD SPECIFICATIONS MANUAL (“TCSS MANUAL”) OF THE CITY OF MARBLE FALLS, TEXAS, 1ST ED., DATED AUGUST 2017; AMENDING CHAPTER 11, “FLOOD DAMAGE PREVENTION,” SECTION 11-33 “STANDARDS FOR SUBDIVISION PROPOSALS,” BY REQUIRING SUBDIVISION PROPOSALS TO CONFORM TO THE TCSS MANUAL; AMENDING CHAPTER 28, “NONPOINT SOURCE POLLUTION CONTROL,” SECTION 28-53, “NONPOINT SOURCE POLLUTION CONTROL APPROVAL,” BY REQUIRING CERTAIN DEVELOPMENT TO COMPLY WITH THE TCSS MANUAL; AMENDING APPENDIX B, “LAND USE REGULATIONS,” REQUIRING COMPLIANCE WITH THE TCSS MANUAL AS IT RELATES TO LAND USE REGULATION AND DEFINING THE SAME; PROVIDING PENALTIES UP TO \$2000.00 PER VIOLATION; PROVIDING AN EFFECTIVE DATE, REPEALER, SEVERABILITY, AND PROPER NOTICE AND MEETING.

WHEREAS, The City Council of the City of Marble Falls, Texas (“City Council”), seeks to establish reasonable construction specifications to ensure that the installation of public infrastructure is of a quality acceptable to the City; and

WHEREAS, The City Council has caused to be prepared this ordinance calling for the implementation of certain construction specifications so as to implement and enforce certain necessary standards for the entire jurisdiction of the City of Marble Falls, Texas; and

WHEREAS, The City Council has set forth said construction specifications in the form of an ordinance, herein referred to as the Technical Construction Standard Specifications of the City of Marble Falls, 1st Ed., which Technical Construction Manual includes the Standard Specification and the Standard Details (collectively referred to as the “TCSS”); and

WHEREAS, The City Council seeks to update the City’s construction standards as needed in order to use the latest and most efficient methods of construction; and

WHEREAS, The City Council adopts this ordinance in order to promote the health, welfare, and safety of the City of Marble Falls and its citizens;

NOW, THEREFORE, BE IT ORDAINED BY THE COUNCIL OF THE CITY OF MARBLE FALLS, TEXAS:

SECTION I.

All of the above premises are hereby found to be true and correct legislative and factual findings of the City Council, and are hereby approved and incorporated into the body of this Ordinance as if copied in their entirety.

SECTION II.

A. The Code of Ordinances, Chapter 7, “Buildings and Building Regulations,” is hereby amended, by retitling the same as “Buildings, Building Regulations, and Technical Construction Standard Specification,” and by adding a new Article XIII, which shall be titled “Technical Construction Standard Specifications,” which shall read as follows:

ARTICLE XIII. - TECHNICAL CONSTRUCTION STANDARD SPECIFICATIONS

Sec. 7-331. – Adoption of Technical Construction Standard Specifications

- (a) The Technical Construction Standard Specifications of the City of Marble Falls, 1st Ed., consisting of the Standard Specifications and the Standard Details (collectively the “TCSS Manual”), dated August 2017, as may be amended from time-to-time, is hereby adopted.
- (b) One (1) copy of the TCSS Manual is incorporated herein by reference and shall be filed in the office of development services for permanent record and inspection and a copy shall be maintained on the City’s website.
- (c) All facilities constructed within the existing public right-of-way and utility easements, or newly dedicated right-of-way and utility easements which are intended to be dedicated to the City of Marble Falls, shall comply with the applicable provisions of the TCSS Manual as amended from time to time.
- (d) Unless deleted, amended, expanded, or otherwise changed herein, all provisions of the TCSS Manual shall be fully applicable and binding. In the event a conflict is determined to exist between the TCSS Manual and the laws of the State of Texas, or a federal requirement, the state or federal requirements shall be construed as controlling and taking precedence over this ordinance.
- (e) The TCSS Manual shall be comprised of the construction requirements and standard details for trenching and backfilling, concrete, water system, sewer system, streets, sidewalks, and driveways, storm drainage, and as otherwise set forth in the TCSS Manual. The TCSS may also include any additional provisions or requirements of the City of Marble Falls that pertain to the construction of site improvements such as streets, parking lots, driveways and sidewalk paving, storm

drainage structures, utility lines and facilities, screening walls/fences, retaining walls, landscaping and irrigation improvements, street lighting or signage, restricted access (gated) entrances to any type of development, and other similar improvements.

- (f) The City Manager or designee shall have the authority to determine whether or not the engineering plans for any type of site improvement are in conformance with the City's TCSS Manual.

B. The Code of Ordinances, Chapter 11, “Flood Damage Prevention,” section 11-33 “Standards for subdivision proposals,” is hereby amended by adding a new subsection (f), which shall read as follows:

- (f) All subdivision proposals shall comply with the TCSS Manual as adopted within section 7-331 of this code of ordinances, as may be amended from time to time.

C. The Code of Ordinances, Chapter 28, “Nonpoint Source Pollution Control,” section 28-53, “Nonpoint source pollution control approval,” is hereby amended by adding a new subsection (a)(3), which shall read as follows:

- (a)(3) All development, redevelopment, or other construction that occurs within the right of way, public easement, or construction that is, or is intended to be, dedicated to the City, shall comply with the TCSS Manual as adopted in section 7-331 of this code of ordinances, as may be amended from time to time.

D. The Code of Ordinances, Appendix B, “Land Use Regulations,” section 803, “Application of regulations,” is hereby amended by adding a new subsection b.8., which shall read as follows:

- b.8. The City of Marble Falls’ TCSS Manual, as adopted within section 7-331 of this code of ordinances, as may be amended from time to time.

E. The Code of Ordinances, Appendix B, “Land Use Regulations,” section 1007, “Access development (driveways and curb cuts)—title and purpose,” is hereby amended by adding a new subsection D.4., which shall read as follows:

- D.4. All construction within the right of way, and construction that is, or is intended to be, dedicated to the City, shall comply with the latest TCSS Manual, as adopted in section 7-331 of this code of ordinances, as may be amended from time to time.

F. The Code of Ordinances, Appendix B, “Land Use Regulations,” within the subchapter entitled “Definitions”, is hereby amended by adding a new subsection 394, which shall read as follows; all other definitions within said subchapter shall be re-numbered accordingly:

394. TCSS Manual. The City of Marble Falls Technical Construction Standard Specifications and the Standard Details (“TCSS” or “TCSS Manual”), as adopted within section 7-331 of this code of ordinances, as may be amended from time to time, for the construction standards and standard details associated with construction of improvements that shall be public infrastructure, or connecting to public infrastructure within the right-of-way, and/or connecting to public streets, alleys, or improved systems, or access points dedicated to the City.

III. SEVERABILITY

If any provision, section, sentence, clause or phrase of this Ordinance, or the application of same to any person or set of circumstances is for any reason held to be unconstitutional, void, invalid, or unenforceable, the validity of the remaining portions of this Ordinance or its application to other persons or sets of circumstances shall not be affected thereby, it being the intent of the City Council of the City of Marble Falls in adopting, and of the Mayor in approving this Ordinance, that no portion hereof or provision or regulation contained herein shall become inoperative or fail by reason of any unconstitutionality or invalidity of any portion, provision or regulation.

IV. REPEALER

All ordinances and parts of ordinances that are in conflict with this ordinance are hereby repealed.

V. PENALTY

A violation of any section of this ordinance shall be punishable as a misdemeanor under the provisions stated in Chapter 1, Section 1-9 of the Code of Ordinances of the City of Marble Falls.

VI. EFFECTIVE DATE

This Ordinance shall be and become effective immediately upon and after its passage and publication as may be required by governing law.

VII. PROPER NOTICE AND MEETING

It is hereby officially found and determined that the meeting at which this Ordinance was adopted was open to the public and that public notice of the time, place and purpose of said meeting was given as required by the Open Meetings Act, Chapter 551 of the Texas Government Code.

ADOPTED AND APPROVED on this 19th day of September, 2017 by a vote of the City Council of the City of Marble Falls, Texas.

CITY OF MARBLE FALLS, TEXAS



John Packer
John Packer, Mayor

ATTEST:

APPROVED AS TO FORM:

Christina McDonald
Christina McDonald, TRMC, City Secretary

Patty L. Akers
Patty L. Akers, City Attorney

STANDARD DETAILS

CITY OF MARBLE FALLS, TX

ENGINEERING DEPARTMENT

FIRST EDITION - AUGUST, 2017

EFFECTIVE DATE - SEPTEMBER, 2017

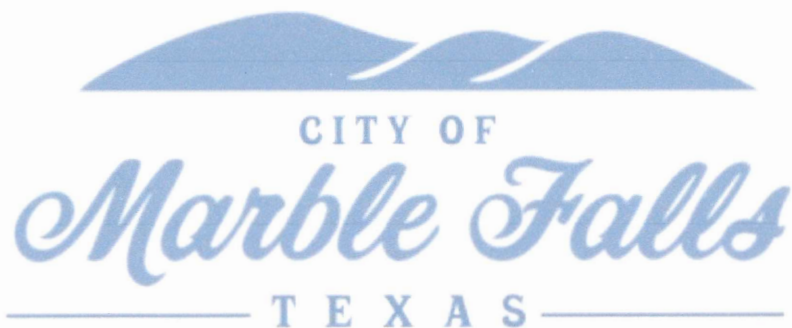

800 Third Street
Marble Falls, Texas 78654

These Documents were prepared by
or under the supervision of:



[Handwritten Signature] 9/8/17

TABLE OF CONTENTS

I - TABLE OF CONTENTS	I
II - INTRODUCTION	
Authorization II.1	V
Scope II.2	V
Design Responsibility II.3.....	V
Methods of Use II.4	VI
III – STANDARD DETAILS	
Tree Protection Details:	
Tree Protection – Chain Link Fence	TP01
Tree Protection – Wood Slats	TP02
Erosion Control Details:	
Temporary Erosion and Sedimentation Guidelines	EC01
Silt Fence	EC02
Silt Fence - J-Hook	EC03
Triangular Filter Dike	EC04
Rock Berm	EC05
Channel Rock Berm	EC06
Curb Inlet Protection	EC07
Area Inlet Protection	EC08
Sediment Trap	EC09
Construction Exit	EC10
Concrete Washout.....	EC11
Construction Staging	EC12
Level Spreader	EC13
Sanitary Sewer Details:	
Embedment Under Unpaved Areas.....	WW01
Embedment Under Proposed Pavement	WW02
Embedment Under Existing Pavement	WW03
Concrete Cap Embedment.....	WW04
Standard 48” Flat Lid Manhole	WW05
Manhole Vent	WW06
Flexible “Seal Boot” Connector.....	WW07
Type 4 - Pickbar	WW08
Service Connection to Existing Lines	WW09
Service Line	WW10
Standard Manhole - Plan.....	WW11
Standard Manhole - Section	WW12
Concentric Top Section	WW13
Force Main Connection to Existing Manhole.....	WW14
Drop Connection Manhole - Type ‘A’	WW15
Drop Connection Manhole - Type ‘B’	WW16
Manhole Concrete Apron	WW17
Invert Flow Patterns	WW18
Clean Out	WW19
Wastewater Valve	WW20
In-Line Valve.....	WW21

Air Release/Vacuum Valve	WW22
Flush Connection	WW23
Long Residential FM Service Line (Plan)	WW24
Long Residential FM Service Line (Section)	WW25
Long Non-Residential FM Service Line (Plan)	WW26
Long Non-Residential FM Service Line (Section)	WW27
Short Residential FM Service Line (Plan)	WW28
Short Residential FM Service Line Plan (Section)	WW29
Short Non-Residential FM Service Line (Plan)	WW30
Short Non-Residential FM Service Line (Section)	WW31
Pipe Casing	WW32
Mandrel	WW33
FM Culvert Crossing	WW34
Proposed WW Over Water Main Crossing	WW35
Proposed FM Under Water Main Crossing	WW36
Check Valve Assembly	WW37
Lift Station Top Plan View (1 of 3)	WW38
Lift Station Top Bearing Ring (2 of 3)	WW39
Lift Station Top Bearing Ring (3 of 3)	WW40
Lift Station Foundation	WW41
Odor Control Slab	WW42
Proposed WW Line Under Proposed Water	WW43
Manhole O-Ring Joint	WW44
Manhole Wedge Seal Joint	WW45
Manhole Sealed Frame & Lid	WW46

Water Details:

Embedment Under Unpaved Areas	WT01
Embedment Under Proposed Pavement	WT02
Embedment Under Existing Pavement	WT03
Concrete Cap Embedment	WT04
Concrete Encased Pipe	WT05
Double Service Plan	WT06
Double Service Section	WT07
Single ¾" to 1" Service	WT08
Single 1.5" to 2" Service	WT09
Single 1.5" to 2" Service Material List	WT10
Single 2" Service	WT11
4" Compound Meter (1 of 2)	WT12
4" Compound Meter (2 of 2)	WT13
6" Compound Meter (1 of 2)	WT14
6" Compound Meter (2 of 2)	WT15
Service Cut-Off Section	WT16
Water Valve	WT17
In-Line Valve	WT18
Blow-Off Connection	WT19
Standard Fire Hydrant Assembly (1 of 2)	WT20
Parallel Fire Hydrant Assembly (2 of 2)	WT21
Air Release-Vacuum Valve (1 of 2)	WT22
Air Release-Vacuum Valve (2 of 2)	WT23
Flush Connection	WT24
Pressure Reducing Valve	WT25
Dual Pressure Reducing Valve	WT26

Double Check Backflow Preventer	WT27
Fire Department Connection	WT28
Fire Casing.....	WT29
Thrust Blocking	WT30
Fire Hydrant Sample Point	WT31
Bore Under Tree	WT32
Wastewater line Under Water Main Crossing	WT33

Pavement Details:

HMAC Pavement Section	PV01
Paving & Utility Layout Plan (1 of 2)	PV02
Paving & Utility Layout Section (2 of 2).....	PV03
Residential Cul-De-Sac	PV04
Commercial Cul-De-Sac.....	PV05
Standard Curb Section.....	PV06
Mountable Curb Section	PV07
Ribbon Curb Section.....	PV08
Driveway Approach Type 'A'	PV09
Driveway Approach Type 'B'	PV10
Ditch Driveway Approach Type 'C'	PV11
Driveway Section Type '1'	PV12
Curved Driveway Reinforcing Plan	PV13
Flared Driveway Reinforcing Plan.....	PV14
Typical Sidewalk Section	PV15
Perpendicular Ramp Layout (1 of 2).....	PV16
Perpendicular Ramp Section (2 of 2).....	PV17
Parallel Ramp	PV18
Corner Ramp.....	PV19
Ramp Truncated Dome Texturing	PV20
Ramp Handrail (1 of 2)	PV21
Ramp Handrail (2 of 2)	PV22
Valley Gutter.....	PV23
Sign Mount (1 of 2).....	PV24
Sign Mount (2 of 2).....	PV25
Fire Lane Striping (1 of 2)	PV26
Fire Lane Striping (2 of 2)	PV27
Wheelstop.....	PV28
Mailbox	PV29
Bollard	PV30
Barricade.....	PV31
Security Fence.....	PV32
Hike & Bike Trail Section (1 of 2)	PV33
Hike & Bike Trail Section (2 of 2)	PV34
Downtown Sidewalk Section.....	PV35
Cemetery Wall Section	PV36

Drainage Details:

Standard Curb Inlet	SD01
Extended Curb Inlet.....	SD02
Area Inlet.....	SD03
24" Manhole Cover (1 of 2)	SD04
24" Manhole Cover (2 of 2)	SD05
38" Manhole Cover	SD06

Residential Driveway Culvert	SD07
Non-Residential Driveway Culvert	SD08
French Drain	SD09
Concrete Valley Drain	SD10
Sloped End Treatment Type 'A'	SD11
Sloped End Treatment Type 'B' (1 of 2)	SD12
Sloped End Treatment Type 'B' (2 of 2)	SD13
Spillway Treatment.....	SD14
Pilot Channel.....	SD15
Headwall Riprap.....	SD16
Headwall Energy Dissipators.....	SD17
Junction Box (1 of 2).....	SD18
Junction Box (2 of 2).....	SD19

Electrical Details:

Street Light.....	EL01
Electrical & Comm. Pull Box (1 of 2)	EL02
Electrical & Comm. Pull Box (2 of 2)	EL03
Electrical & Comm. Manhole (1 of 2)	EL04
Electrical & Comm. Manhole (2 of 2)	EL05

II. Introduction

II.1 - Authorization

For public infrastructure projects, standard design and construction practices, when applied where appropriate, help to eliminate redundant and repeated designs for the same types of structures, to facilitate plan review, and to allow City personnel to develop in-depth experience with standard designs and practices. To that end, the City Council of the City of Marble Falls, Texas has adopted the Standard Construction Details contained in this Manual, in its capacity as the governing body of the City of Marble Falls, Texas and the area within its Extraterritorial Jurisdiction.

II.2 - Scope

These Standard Details are intended for use in public projects and in projects including infrastructure items which will be accepted for maintenance by the City of Marble Falls within:

- Areas within the City of Marble Falls.
- Areas where the City of Marble Falls owns and/or maintains property, right of way, or easements.
- Areas within the Extraterritorial Jurisdiction of the City of Marble Falls.

To any other projects where specifically required by regulations and/or ordinance of the City of Marble Falls.

These Standard Details have been compiled to provide guidance for engineers and designers within the City of Marble Falls and its ETJ. These Standard Details indicate the City's design preferences for each item, and shall be used unless the designer determines that such use is inappropriate for a specific condition. These Standard Details are intended to be used without modification where appropriate by engineers and designers by simply including a reference to the appropriate Standard Detail in individual sets of Construction Drawings.

II.3 - Design Responsibility

As stated above, these Standard Details are available for use without modification where applicable; however, the determination of whether a particular Standard Detail is applicable to a specific project is the full responsibility of the design professional who uses it. The engineer or designer who uses any Standard Detail(s) takes full responsibility for the use, inclusion, or reference to such detail(s). **The full responsibility for all designs, plans, and specifications will rest with the design professional who produced them.**

II.4 - Methods of Use

A given set of Construction Drawings may include details created specifically for the project at hand; the drawings may include or reference Standard Details; or, the drawings may include Standard Details that have been modified or revised as needed for a specific situation. In order to make full use of these Standard Details as intended, it is imperative that any details included in Construction Drawings be clearly used and referenced in a manner that allows plan reviewers and field personnel to distinguish between actual standards and details that are specific or have been revised. Therefore, for use of these Standard Details, the methodology to be used is described immediately below and illustrated in the examples that follow:

Each of the Standard Details included in this Manual is individually numbered, with the number shown in the lower right-hand corner of each drawing. Standard Details in this Manual that are being used without modification need not actually be included in Construction Drawings; the Construction Drawings shall reference the detail to be used by calling out the detail number. For example, to reference the Standard Detail for a Culvert Crossing for Sewer Lines, Detail no. WW26, a callout in the construction plans for: "WW26" should be used as shown in Figure 1a below.

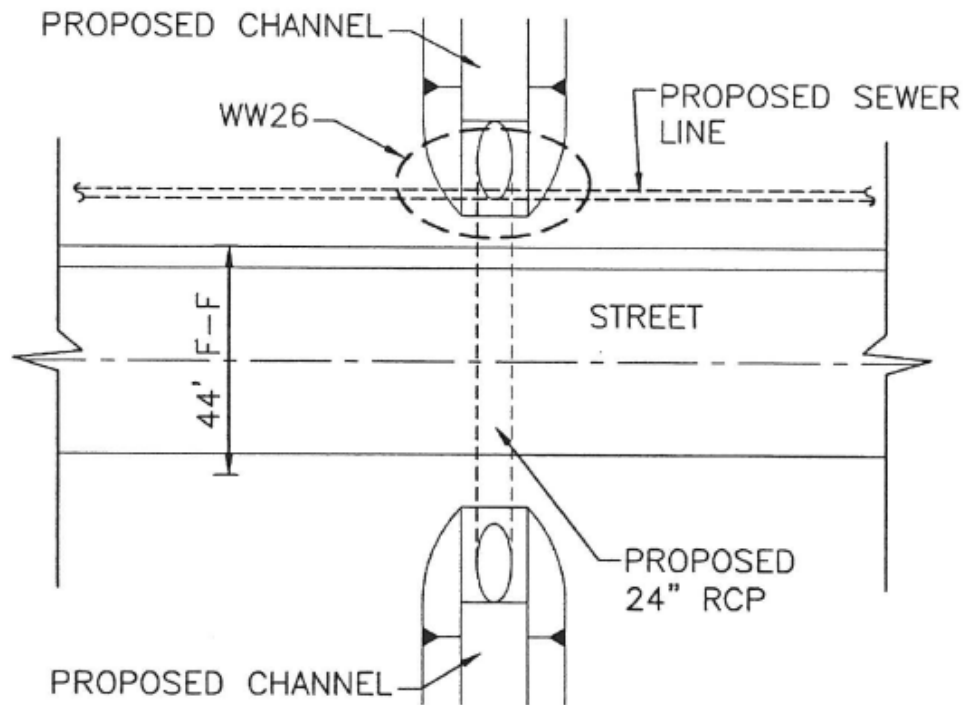

Figure 1a Typical Plan Sheet with Callout for Standard Detail

Figure 1b, below, is a copy of the Standard Detail in this Manual.

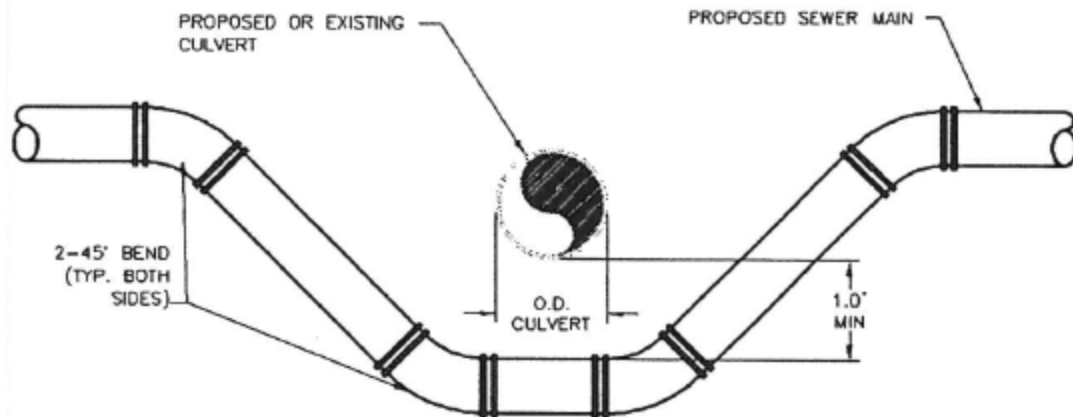

Figure 1b Standard Detail (from this Manual)

When a reference is made as shown in Figure 1a, the physical page containing the actual Standard Detail need not be actually included in the plans; however, in that case, it is imperative that this Manual in its entirety be made a part of the Construction Documents, both during the bidding process and during the construction process.

When a Standard Detail has been revised or modified, the revised or modified detail must be physically included in the details section of construction plans with the area of revision(s) clouded and clear notes attached that describe the revision(s). The revised detail shall be referenced in the construction plans by adding the letter: "R" to the detail number. For example, to revise the Culvert Crossing for Sewer Lines detail to provide for additional clearance between the culvert and the proposed sewer line, show the location of the detail in the construction plans called out as: "RWW26" and include the revised detail in the detail section of the Construction Drawings as shown in Figures 2a and 2b.

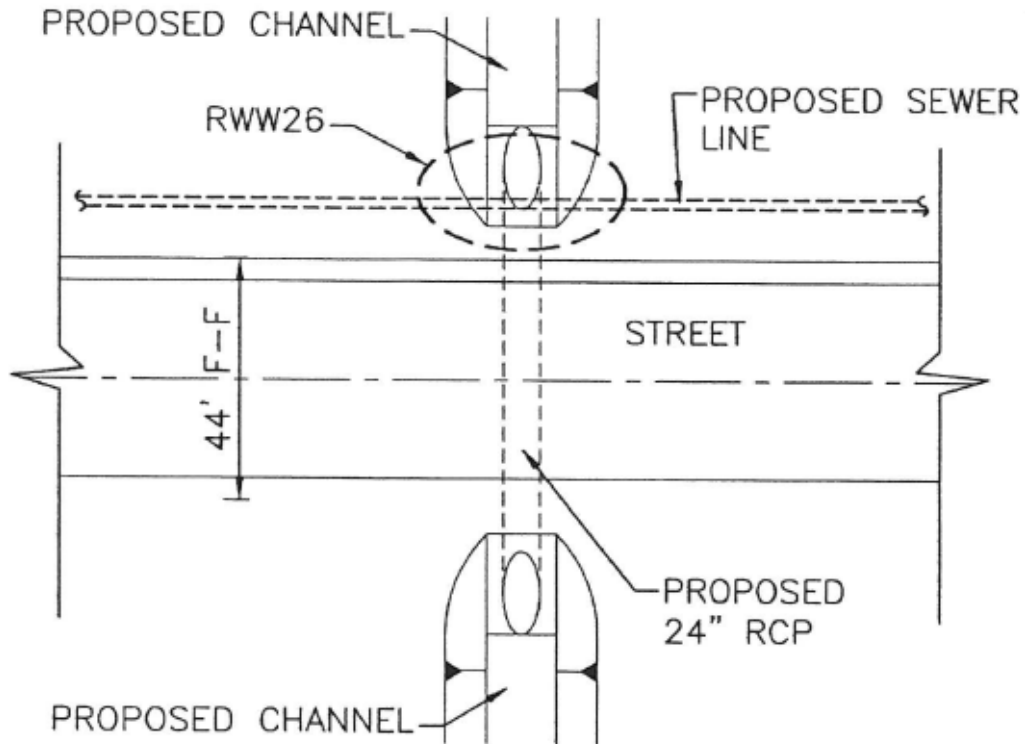

Figure 2a Typical Plan Sheet with Callout for Revised Detail

Figure 2b, on the following page, shows the revision, cloud, and note required for a revision to a Standard Detail. As noted above, the revised detail shall be included in the Construction Drawings. This allows plan reviewers and field personnel to quickly locate areas of revisions that may require additional review or discussion.

In addition, the Title Sheet, or General Notes Sheet of the construction plans must contain a prominent note listing all the Standard Details, including those that have been revised that are included in the plan set. The note must contain the following statement: "The following City of Marble Falls Standard Details have been included in this plan set and are applicable to this project." The note must list all Standard and Revised Details by number and include the signature of the design professional responsible for the plan set. For example, to include the two details used in Figures 1 and 2, the following note must be used:

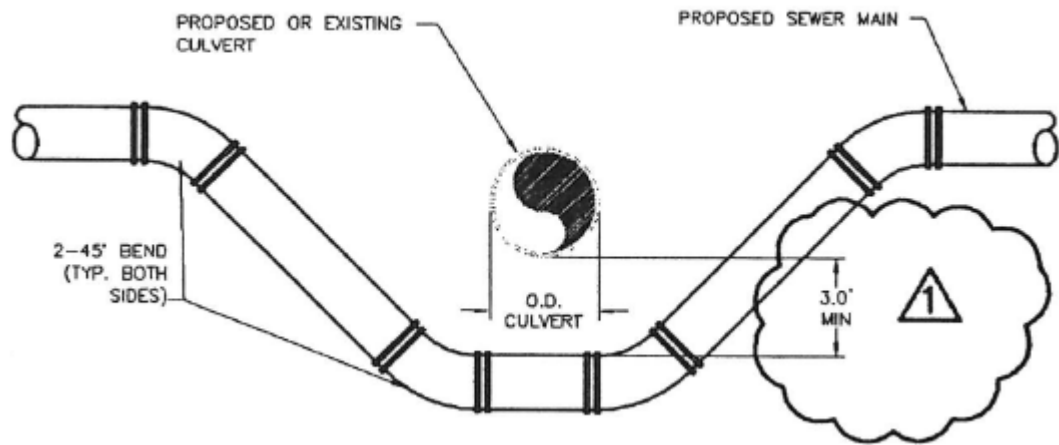
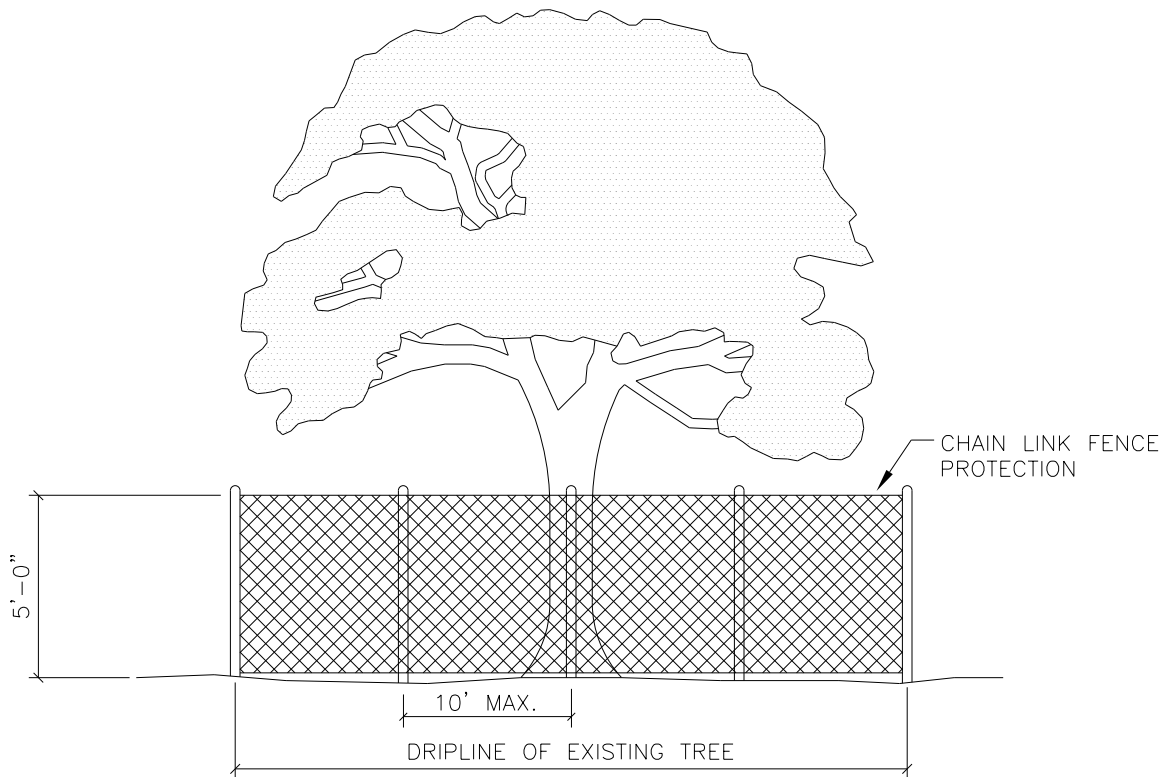

Figure 2b Revised Detail (must be included in Construction Drawings)

For use of any other details that are physically included in the Construction Drawings, the designer may use any appropriate means of calling out and locating such details.

The following City of Marble Falls Standard Details have been included or referenced in this plan set and are applicable to this project:



TREE PROTECTION NOTES:

1. TREE PROTECTION FENCES SHALL BE INSTALLED PRIOR TO THE COMMENCEMENT OF ANY SITE PREPARATION WORK (CLEARING, GRUBBING OR GRADING).
2. FENCES SHALL COMPLETELY SURROUND THE TREE, OR CLUSTERS OF TREES; WILL BE LOCATED AT THE OUTERMOST LIMIT OF THE TREE BRANCHES (DRIPLINE), AND WILL BE MAINTAINED THROUGHOUT THE CONSTRUCTION PROJECT IN ORDER TO PREVENT THE FOLLOWING:
 - A. SOIL COMPACTION IN THE ROOT ZONE AREA RESULTING FROM VEHICULAR TRAFFIC, OR STORAGE OF EQUIPMENT OR MATERIALS.
 - B. ROOT ZONE DISTURBANCES DUE TO GRADE CHANGES (GREATER THAN SIX INCHES (6") CUT OR FILL, OR TRENCHING NOT REVIEWED AND AUTHORIZED BY THE CITY.
 - C. WOUNDS TO EXPOSED ROOTS, TRUNKS OR LIMBS BY MECHANICAL EQUIPMENT.
 - D. OTHER ACTIVITIES DETRIMENTAL TO TREES, SUCH AS CHEMICAL STORAGE, CEMENT TRUCK CLEANING AND FIRE.
3. EXCEPTIONS TO INSTALLING FENCES AT TREE DRIPLINES MAY BE PERMITTED IN THE FOLLOWING CASES:
 - A. WHERE PERMEABLE PAVING IS TO BE INSTALLED, ERECT THE FENCE AT THE OUTER LIMITS OF THE PERMEABLE PAVING AREA.
 - B. WHERE TREES ARE CLOSE TO PROPOSED BUILDINGS, ERECT THE FENCE NO CLOSER THAN SIX FEET (6'-0") TO BUILDING.

SCALE: NOT TO SCALE



MARBLE FALLS
 800 THIRD STREET
 MARBLE FALLS, TX 78654
 PH: (830) 693-6737

These documents were prepared by,
 or under the supervision of:

ERIC BELAJ 107148 May 31, 2017
 Engineer's Name PE# Date

 Engineer's Signature

SECTION EROSION CONTROL
DETAIL NO. TP-1
TITLE TREE PROTECTION CHAIN LINK FENCE

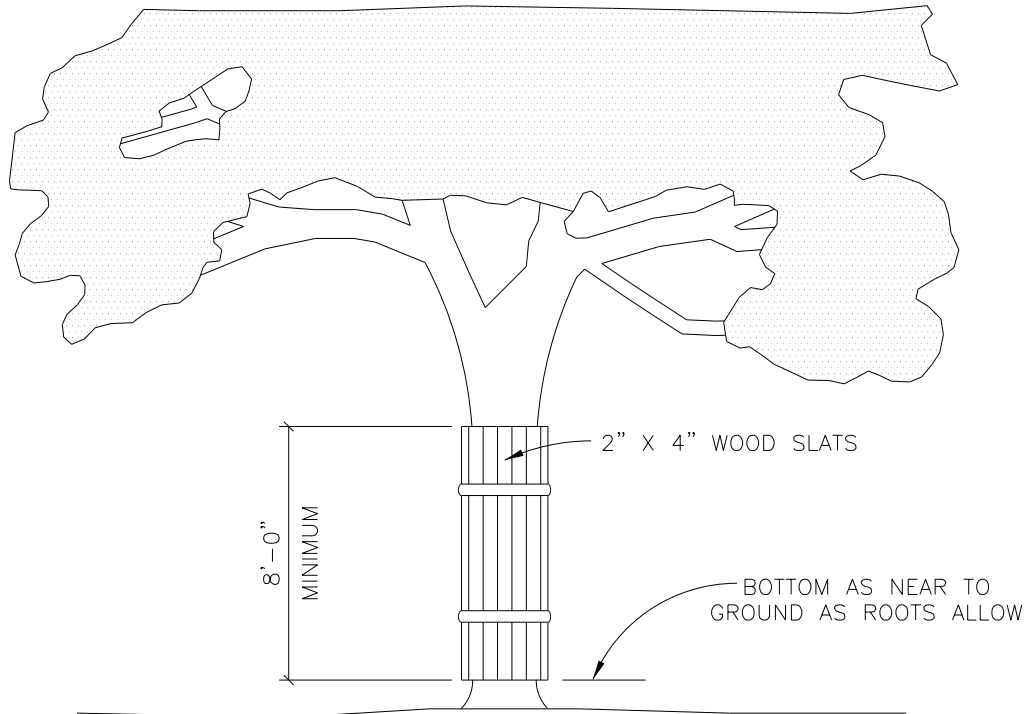

TREE PROTECTION NOTES:

1. WHERE ANY EXCEPTIONS RESULT IN A FENCE BEING CLOSER THAN FOUR FEET (4'-0") TO A TREE TRUNK; PROTECT THE TRUNK WITH STRAPPED-ON-PLANKING TO A HEIGHT OF EIGHT FEET (8'-0"), OR TO THE LIMITS OF LOWER BRANCHING IN ADDITION TO THE REDUCED FENCING PROVIDED.
2. ANY ROOTS EXPOSED BY CONSTRUCTION ACTIVITY SHALL BE PRUNED FLUSH WITH THE SOIL. BACKFILL ROOT AREAS WITH GOOD QUALITY TOP SOIL AS SOON AS POSSIBLE. IF EXPOSED ROOT AREAS ARE NOT BACKFILLED WITHIN TWO (2) DAYS, COVER THEM WITH ORGANIC MATERIAL IN A MANNER WHICH REDUCES SOIL TEMPERATURE, AND MINIMIZES WATER LOSS DUE TO EVAPORATION.
3. PRIOR TO EXCAVATION OR GRADE CUTTING WITHIN TREE DRIPLINE. MAKE A CLEAN CUT BETWEEN THE DISTURBED AND UNDISTURBED ROOT ZONES WITH A ROCK SAW OR SIMILAR EQUIPMENT, TO MINIMIZE DAMAGE TO REMAINING ROOTS.
4. TREES MOST HEAVILY IMPACTED BY CONSTRUCTION ACTIVITIES SHOULD BE WATERED DEEPLY ONCE A WEEK DURING PERIODS OF HOT, DRY WEATHER. TREE CROWNS SHOULD BE SPRAYED WITH WATER PERIODICALLY TO REDUCE DUST ACCUMULATION ON THE LEAVES.
5. ANY TRENCHING REQUIRED FOR THE INSTALLATION OF LANDSCAPE IRRIGATION SHALL BE PLACED AS FAR FROM EXISTING TREE TRUNKS AS POSSIBLE.
6. NO LANDSCAPE TOPSOIL DRESSING GREATER THE FOUR INCHES (4") SHALL BE PERMITTED WITHIN THE DRIPLINE OF A TREE. NO SOIL IS PERMITTED ON THE ROOT FLARE OF ANY TREE.
7. PRUNING TO PROVIDE CLEARANCE FOR STRUCTURES, VEHICULAR TRAFFIC AND EQUIPMENT SHALL TAKE PLACE BEFORE CONSTRUCTION BEGINS.

SCALE: NOT TO SCALE



MARBLE FALLS
 800 THIRD STREET
 MARBLE FALLS, TX 78654
 PH: (830) 693-6737

These documents were prepared by,
 or under the supervision of:

ERIC BELAJ 107148 May 31, 2017
 Engineer's Name PE# Date

Engineer's Signature

SECTION	EROSION CONTROL
DETAIL NO.	TP-2
TITLE	TREE PROTECTION WOOD SLATS

Guidelines for Selection of Temporary Erosion and Sedimentation Controls

CONTROL TYPE	APPLICATION	DRAINAGE AREA	SLOPE	SPACING
SILT FENCE (Interior)	Areas of sheet flow or very minor channel flow	2 Acres	<20%	200 ft.
SILT FENCE (Perimeter)	Downslope borders of site; upslope border if necessary to divert offsite drainage	N/A	N/A	200 ft.
TRIANGULAR FILTER DIKE	Areas within site requiring frequent vehicular access	1 Acre	<10%	N/A
ROCK BERM	Drainage swales and ditches within and below site	5 Acres	<30%	150 ft.
HIGH SERVICE ROCK BERM	Near critical features, high flow areas within and below site	5 Acres	<30%	150 ft.
INLET PROTECTION	Storm sewer inlets receiving drainage	N/A	N/A	N/A
SEDIMENT BASIN	Appropriate for large disturbed areas	5-100 Acres	N/A	N/A
CONSTRUCTION EXIT	Should be used at all designated access points	N/A	N/A	N/A
CONCRETE WASHOUT	Use on all concrete pouring operations	N/A	N/A	N/A

SCALE: NOT TO SCALE



MARBLE FALLS
800 THIRD STREET
MARBLE FALLS, TX 78654
PH: (830) 693-6737

These documents were prepared by,
or under the supervision of:

ERIC BELAJ 107148 May 31, 2017
Engineer's Name PE# Date

A handwritten signature in black ink, appearing to read "Eric Belaj", is written over a horizontal line.

Engineer's Signature

SECTION

EROSION CONTROL

DETAIL NO.

EC-1

TITLE

TEMPORARY EROSION AND
SEDIMENTATION GUIDELINES

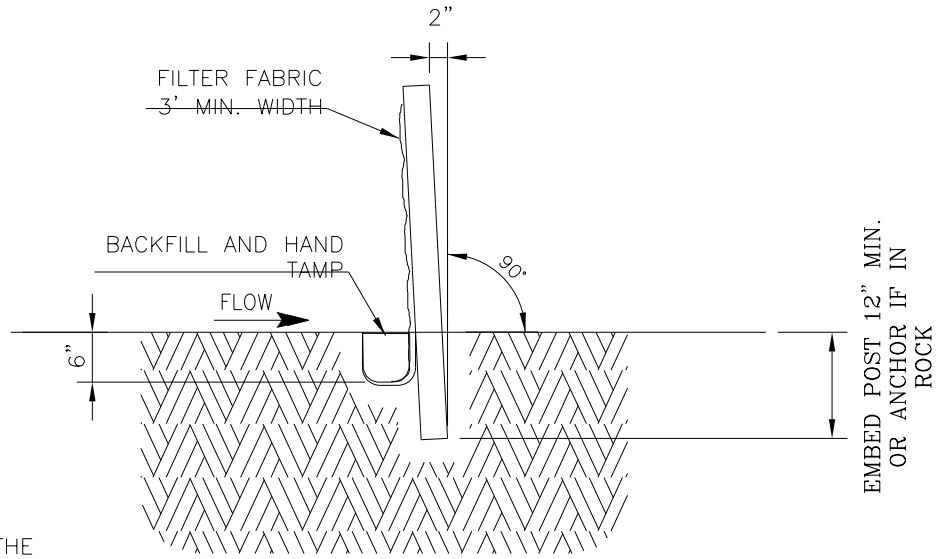

SECTION A-A

CONNECT ENDS OF THE SUCCESSIVE REINFORCEMENT SHEETS OR ROLLS A MIN. OF 6 TIMES WITH HOG RINGS.

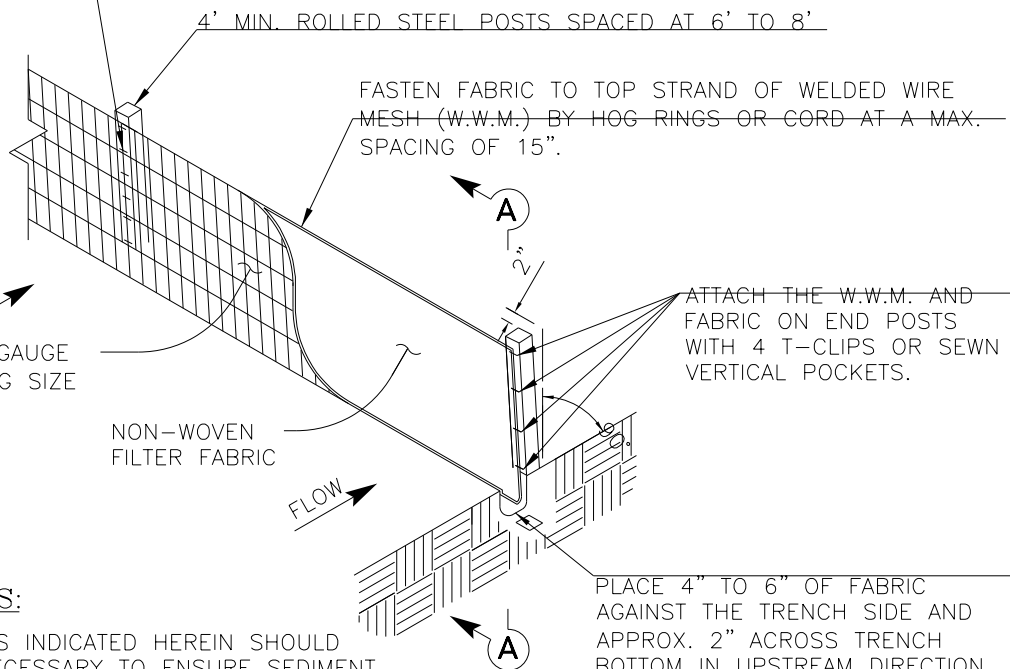

GALV. W.W.M. (12 GAUGE MIN.) MAX. OPENING SIZE SHALL BE 2"x4".

NON-WOVEN FILTER FABRIC

ATTACH THE W.W.M. AND FABRIC ON END POSTS WITH 4 T-CLIPS OR SEWN VERTICAL POCKETS.

PLACE 4" TO 6" OF FABRIC AGAINST THE TRENCH SIDE AND APPROX. 2" ACROSS TRENCH BOTTOM IN UPSTREAM DIRECTION. MIN. TRENCH SIZE SHALL BE 6" SQUARE. BACKFILL AND HAND TAMP.

SILT FENCE NOTES:

1. THE DESIGN DETAILS INDICATED HEREIN SHOULD BE MODIFIED AS NECESSARY TO ENSURE SEDIMENT DOES NOT LEAVE THE PROJECT SITE.

SILT FENCE USAGE GUIDELINES

A SILT FENCE MAY BE CONSTRUCTED NEAR THE DOWNSTREAM PERIMETER OF A DISTURBED AREA ALONG A CONTOUR TO INTERCEPT SEDIMENT FROM OVERLAND RUNOFF.

SCALE: NOT TO SCALE



MARBLE FALLS
800 THIRD STREET
MARBLE FALLS, TX 78654
PH: (830) 693-6737

These documents were prepared by,
or under the supervision of:

ERIC BELAJ 107148 May 31, 2017
Engineer's Name PE# Date

[Signature]
Engineer's Signature

SECTION EROSION CONTROL
DETAIL NO. EC-2
TITLE SILT FENCE

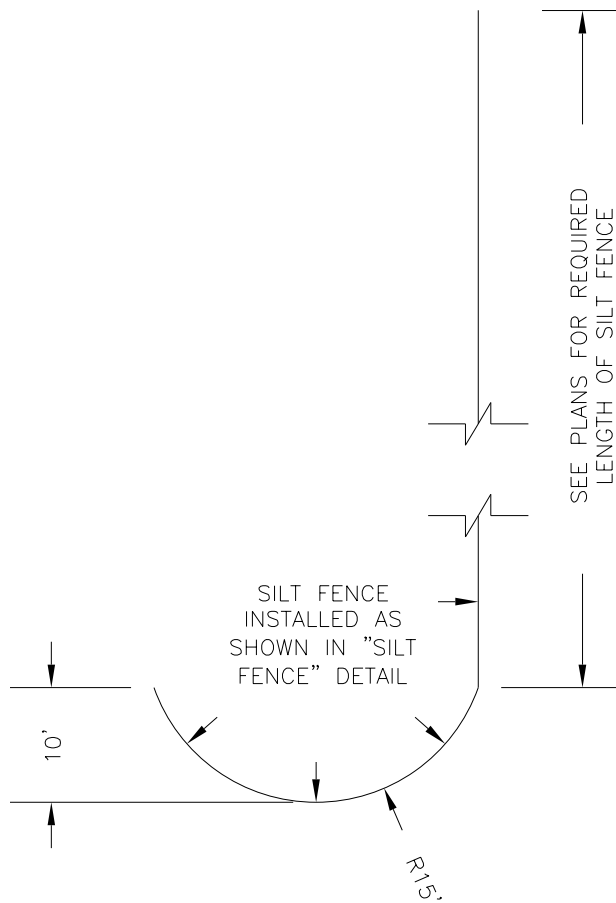

PLAN

SCALE: NOT TO SCALE



MARBLE FALLS
 800 THIRD STREET
 MARBLE FALLS, TX 78654
 PH: (830) 693-6737

These documents were prepared by,
 or under the supervision of:

ERIC BELAJ 107148 May 31, 2017
 Engineer's Name PE# Date

Engineer's Signature

SECTION

EROSION CONTROL

DETAIL NO.

EC-3

TITLE

SILT FENCE - J HOOK

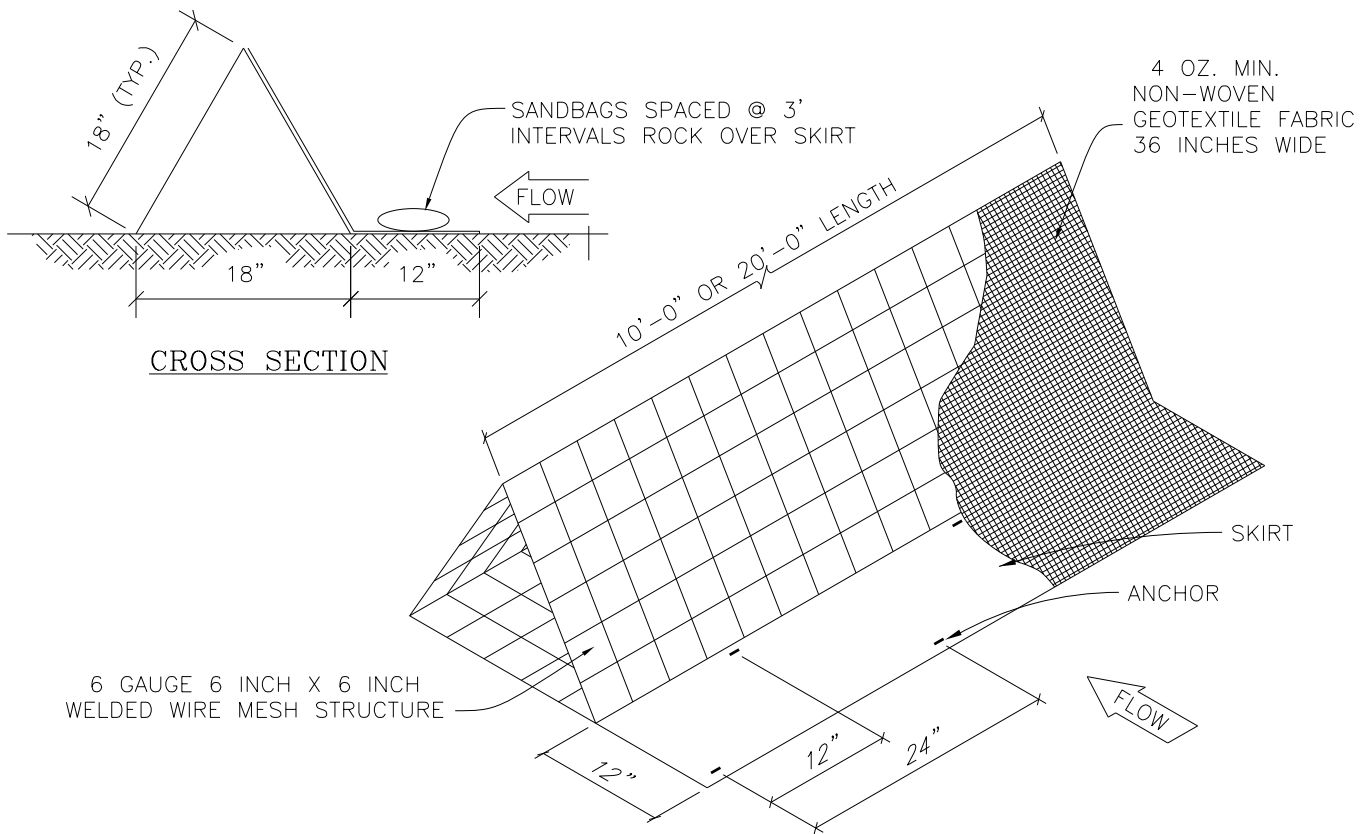

CROSS SECTION

INSTALLATION:

- LAYOUT THE FILTER DIKE FOLLOWING AS CLOSELY AS POSSIBLE TO THE CONTOUR.
- CLEAR THE GROUND OF DEBRIS, ROCKS OR PLANTS THAT WILL INTERFERE WITH INSTALLATION.
- PLACE THE FILTER DIKE SECTIONS ONE AT A TIME, WITH THE SKIRT ON THE UPHILL SIDE TOWARDS THE DIRECTION OF FLOW, ANCHORING EACH SECTION TO THE GROUND BEFORE THE NEXT SECTION IS PLACED.
- SANDBAGS SHOULD BE PLACED ON 3' CENTERS BETWEEN ANCHORS.
- SECURELY FASTEN THE SKIRT FROM ONE SECTION OF FILTER DIKE TO THE NEXT.
- FILTER DIKES MUST MAINTAIN CONTINUOUS CONTACT WITH THE GROUND.
- AFTER THE SITE IS COMPLETELY STABILIZED, THE DIKES AND ANY REMAINING SILT SHOULD BE REMOVED. SILT SHOULD BE DISPOSED OF IN A MANNER THAT WILL NOT CONTRIBUTE TO ADDITIONAL SILTATION.

INSPECTION AND MAINTENANCE GUIDELINES:

- INSPECTION SHOULD BE MADE WEEKLY OR AFTER EACH RAINFALL EVENT AND REPAIR OR REPLACEMENT SHOULD BE MADE PROMPTLY AS NEEDED BY THE CONTRACTOR.
- INSPECT AND REALIGN BERMS AS NEEDED TO PREVENT GAPS BETWEEN THE SECTIONS.
- ACCUMULATED SILT SHOULD BE REMOVED AFTER EACH RAINFALL EVENT, AND DISPOSED OF IN A MANNER WHICH WILL NOT CAUSE ADDITIONAL SILTATION.

SCALE: NOT TO SCALE



MARBLE FALLS
 800 THIRD STREET
 MARBLE FALLS, TX 78654
 PH: (830) 693-6737

These documents were prepared by,
 or under the supervision of:

ERIC BELAJ 107148 May 31, 2017
 Engineer's Name PE# Date

Engineer's Signature

SECTION
EROSION CONTROL

DETAIL NO.
EC-4

TITLE
 TRIANGULAR FILTER DIKE

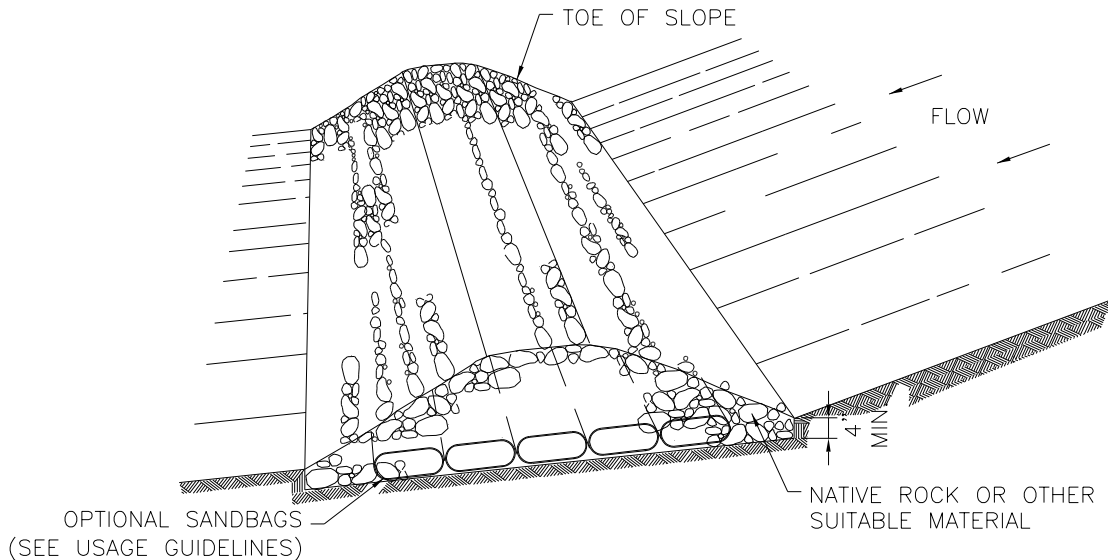

ROCK BERM NOTES:

1. IF SHOWN ON THE PLANS OR AS REQUIRED TO PREVENT OFF-SITE SEDIMENTATION, BERMS SHALL BE PLACED NEAR THE TOE OF SLOPES WHERE EROSION IS ANTICIPATED, UPSTREAM AND/OR DOWNSTREAM AT DRAINAGE STRUCTURES, AND IN ROADWAY DITCHES AND CHANNELS TO COLLECT SEDIMENT.
2. THE ROCK BERMS DIMENSIONS SHALL BE AS INDICATED ON THE DETAIL SHEETS.
3. SIDE SLOPES TO BE 2:1 OR FLATTER.
4. MAINTAIN A MIN. OF 1' BETWEEN TOP OF ROCK BERMS WEIR AND TOP OF EMBANKMENT FOR BERMS.
5. BERMS SHALL BE EMBEDDED A MINIMUM OF 4" INTO EXISTING GROUND.
6. ROCK BERMS TYPE 2 & 3 SHALL BE SECURED WITH 20 GAUGE GALVANIZED WOVEN WIRE MESH WITH 1" DIAMETER HEXAGONAL OPENINGS. THE AGGREGATE SHALL BE PLACED ON THE MESH TO THE HEIGHT & SLOPE SPECIFIED. THE MESH SHALL BE FOLDED AT THE UPSTREAM SIDE OVER THE AGGREGATE AND TIGHTLY SECURED TO ITSELF ON THE DOWNSTREAM SIDE USING WIRE TIES OR HOG RINGS. IN STREAMS THE MESH SHOULD BE SECURED OR STAKED TO THE STREAM BED PRIOR TO AGGREGATE PLACEMENT.
7. SACK GABIONS SHOULD BE STAKED DOWN WITH 3/4" DIA. REBAR STAKES.
8. FLOW OUTLET SHOULD BE ON A STABILIZED AREA (VEGETATION, ROCK, ETC.)
9. THE DESIGN DETAILS INDICATED HEREIN SHOULD BE MODIFIED AS NECESSARY TO ENSURE SEDIMENT DOES NOT LEAVE THE PROJECT SITE.

ROCK BERMS SHOULD BE CONSTRUCTED DOWNSTREAM FROM UNDISTURBED AREAS TO INTERCEPT SEDIMENT FROM OVERLAND RUNOFF AND/OR CONCENTRATED FLOW.

TYPE 1 (18" HIGH WITH NO WIRE MESH): TYPE 1 MAY BE USED AT THE TOE OF SLOPES, AROUND INLETS, IN SMALL DITCHES, AND AT DIKE OR SWALE OUTLETS. THIS TYPE OF DAM IS RECOMMENDED TO CONTROL EROSION FROM DRAINAGE AREAS OF 5 ACRES OR LESS. TYPE 1 SHOULD NOT BE USED IN CONCENTRATED HIGH VELOCITY FLOWS (APPROX. 8 FT/SEC OR MORE) IN WHICH AGGREGATE WASH OUT MAY OCCUR. SANDBAGS SHOULD BE USED AT THE EMBEDDED FOUNDATION (4" DEEP MIN.) FOR BETTER FILTERING EFFICIENCY OF LOW FLOWS IF CALLED FOR ON THE PLANS OR AS A RESULT OF ROUTINE INSPECTIONS

TYPE 2 (18" HIGH WITH WIRE MESH): TYPE 2 MAY BE USED IN DITCHES AND AT DIKE OR SWALE OUTLETS.

TYPE 3 (36" HIGH WITH WIRE MESH): TYPE 3 MAY BE USED IN STREAM FLOW AND SHOULD BE SECURED TO THE STREAM BED.

TYPE 4 (SACK GABIONS): TYPE 4 MAY BE USED IN DITCHES AND SMALLER CHANNELS TO FORM AN EROSION CONTROL DAM. SCALE: NOT TO SCALE



MARBLE FALLS
 800 THIRD STREET
 MARBLE FALLS, TX 78654
 PH: (830) 693-6737

These documents were prepared by,
 or under the supervision of:

ERIC BELAJ 107148 May 31, 2017
 Engineer's Name PE# Date

Engineer's Signature

SECTION

EROSION CONTROL

DETAIL NO.

EC-5

TITLE

ROCK BERM

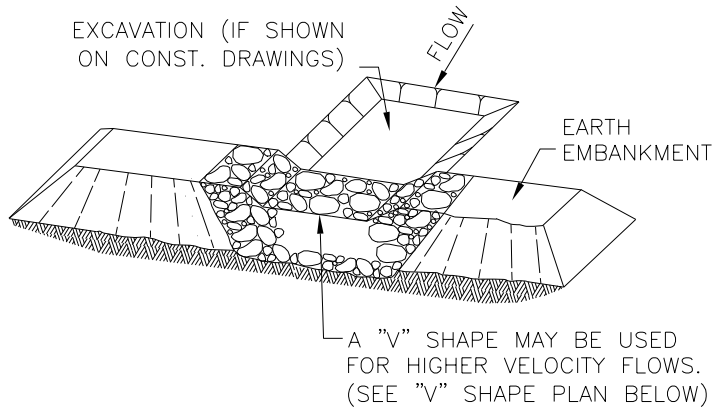

ROCK BERM AT SEDIMENT TRAP
TYPE 1 OR TYPE 2

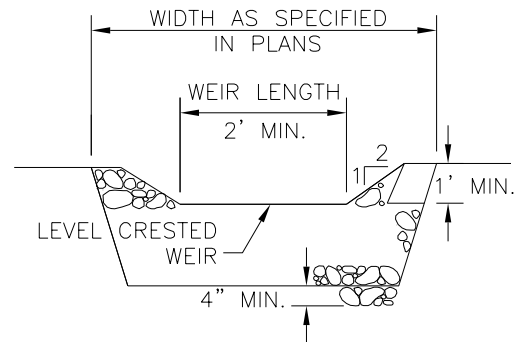

PROFILE OF ROCK BERM AT SEDIMENT TRAP

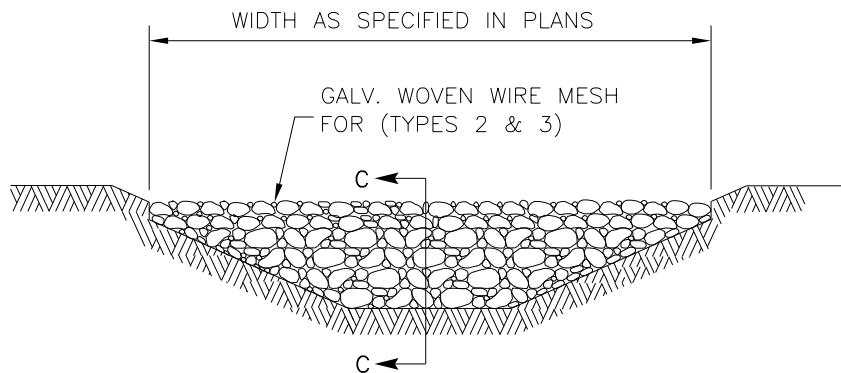

ROCK BERM AT CHANNEL SECTIONS
TYPE 1 OR TYPE 2

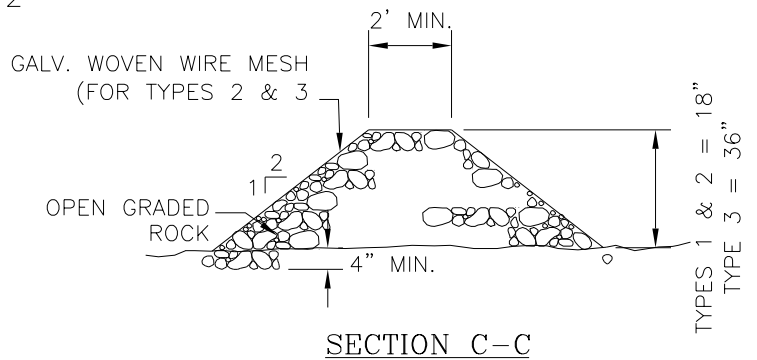

SCALE: NOT TO SCALE



MARBLE FALLS
800 THIRD STREET
MARBLE FALLS, TX 78654
PH: (830) 693-6737

These documents were prepared by,
or under the supervision of:

ERIC BELAJ 107148 May 31, 2017
Engineer's Name PE# Date

Engineer's Signature

SECTION
EROSION CONTROL

DETAIL NO.
EC-6

TITLE
CHANNEL ROCK BERM

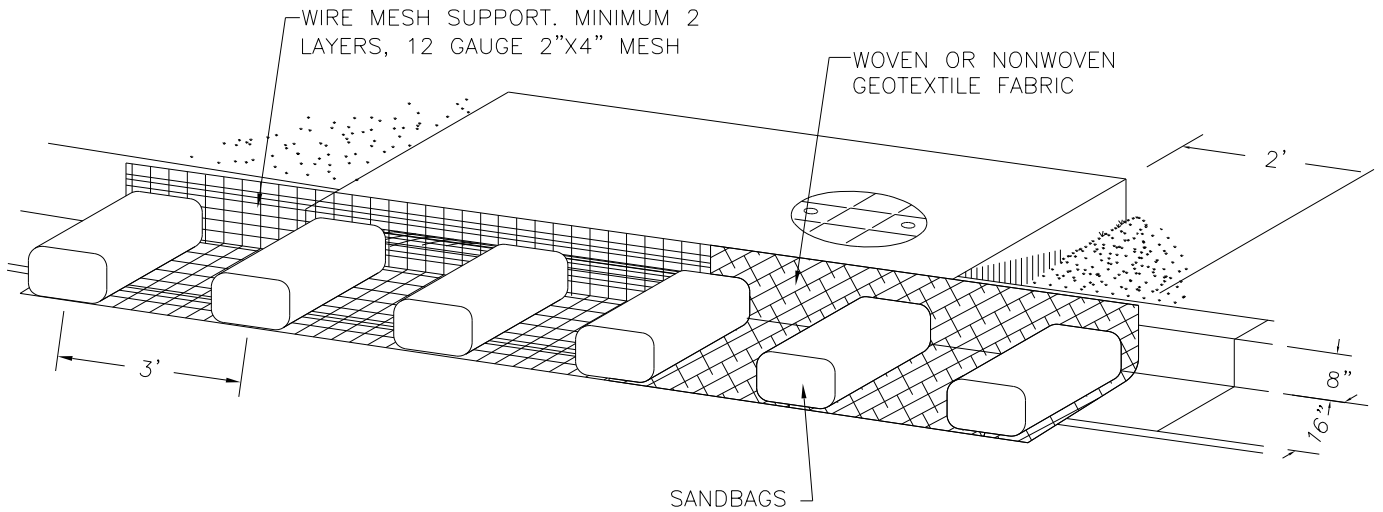

CURB INLET PROTECTION NOTES:

1. WHEN A SANDBAG IS FILLED WITH MATERIAL, THE OPEN END OF THE SANDBAG SHOULD BE STAPLED OR TIED WITH NYLON OR POLY CHORD.
2. INLET PROTECTION SHALL BE PLACED OVER THE MOUTH OF THE INLET WITH A 2 FOOT OVERLAP ON EITHER SIDE.
3. THE FABRIC SHALL COVER AND BE A CONTINUOUS WRAPPING OF GEOTEXTILE FABRIC.
4. THE SKIRT SHALL BE WEIGHTED WITH ONE MINIMUM 18"x24"x6" SANDBAG EVERY 3 FEET.
5. INSPECTION SHALL BE MADE WEEKLY OR AFTER EACH RAINFALL EVENT AND REPAIR OR REPLACEMENT SHALL BE MADE PROMPTLY AS NEEDED BY THE CONTRACTOR.
6. ACCUMULATED SILT SHALL BE REMOVED WHEN IT REACHES A DEPTH OF FOUR INCHES, AND DISPOSED OF IN A MANNER WHICH WILL NOT CAUSE ADDITIONAL SILTATION.
7. AFTER THE DEVELOPMENT SITE IS COMPLETELY STABILIZED, THE INLET PROTECTION AND ANY REMAINING SILT SHALL BE REMOVED. SILT SHALL BE DISPOSED OF AS INDICATED IN NOTE 6 ABOVE.

SCALE: NOT TO SCALE



MARBLE FALLS
 800 THIRD STREET
 MARBLE FALLS, TX 78654
 PH: (830) 693-6737

These documents were prepared by,
 or under the supervision of:

ERIC BELAJ 107148 May 31, 2017
 Engineer's Name PE# Date

Engineer's Signature

SECTION
EROSION CONTROL

DETAIL NO.
 EC-7

TITLE
 CURB INLET PROTECTION

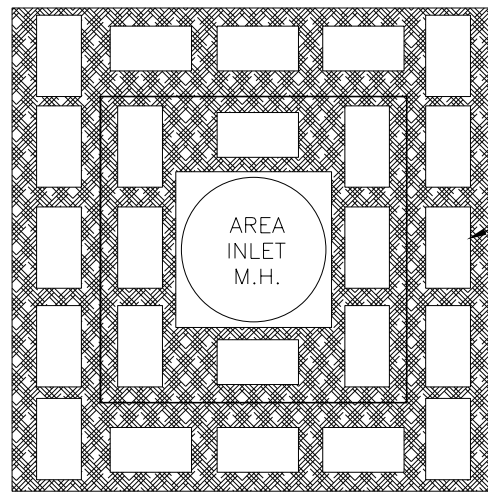

40 LB. SANDBAGS @3' O.C.
(SEE NOTE 1)

12 GAUGE, 2" x 4"
WIRE FABRIC STRUCTURE
(ALL 4 SIDES OF INLET)

PLAN

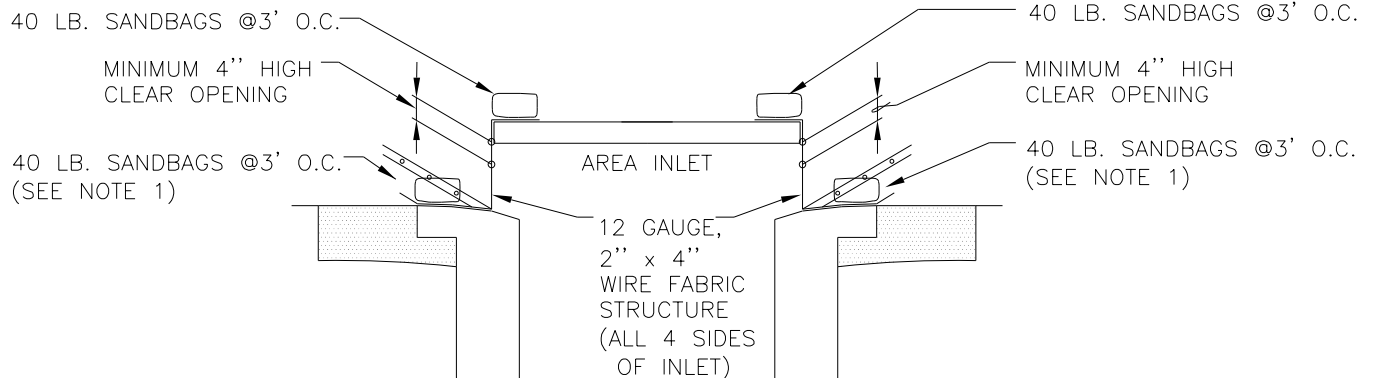

40 LB. SANDBAGS @3' O.C.

MINIMUM 4" HIGH
CLEAR OPENING

40 LB. SANDBAGS @3' O.C.
(SEE NOTE 1)

AREA INLET

12 GAUGE,
2" x 4"
WIRE FABRIC
STRUCTURE
(ALL 4 SIDES
OF INLET)

40 LB. SANDBAGS @3' O.C.

MINIMUM 4" HIGH
CLEAR OPENING

40 LB. SANDBAGS @3' O.C.
(SEE NOTE 1)

SECTION

AREA/GRATE INLET PROTECTION:

1. WHERE MINIMUM CLEARANCES CAUSE TRAFFIC TO DRIVE IN THE GUTTER, THE CONTRACTOR MAY SUBSTITUTE A 1"x4" BOARD SECURED WITH CONCRETE NAILS 3' O.C. NAILED INTO THE GUTTER IN LIEU OF SANDBAGS TO HOLD THE FILTER DIKE IN PLACE. UPON REMOVAL, CLEAN ANY DIRT/DEBRIS FROM NAILING LOCATIONS, APPLY CHEMICAL SANDING AGENT AND APPLY NON-SHRINK GROUT FLUSH WITH SURFACE OF GUTTER.
2. A SECTION OF FILTER FABRIC SHALL BE REMOVED AS SHOWN ON THIS DETAIL OR AS DIRECTED BY THE ENGINEER OR DESIGNATED REPRESENTATIVE. FABRIC MUST BE SECURED TO WIRE BACKING WITH CLIPS OR HOG RINGS AT THIS LOCATION.
3. DAILY INSPECTION SHALL BE MADE BY THE CONTRACTOR AND SILT ACCUMULATION MUST BE REMOVED WHEN DEPTH REACHES 2".
4. CONTRACTOR SHALL MONITOR THE PERFORMANCE OF INLET PROTECTION DURING EACH RAINFALL EVENT AND IMMEDIATELY REMOVE THE INLET PROTECTIONS IF THE STORM-WATER BEGINS TO OVERTOP THE CURB.
5. INLET PROTECTIONS SHALL BE REMOVED AS SOON AS THE SOURCE OF SEDIMENT IS STABILIZED.

SCALE: NOT TO SCALE



MARBLE FALLS

800 THIRD STREET
MARBLE FALLS, TX 78654

PH: (830) 693-6737

These documents were prepared by,
or under the supervision of:

ERIC BELAJ 107148 May 31, 2017
Engineer's Name PE# Date

Engineer's Signature

SECTION

EROSION CONTROL

DETAIL NO.

EC-8

TITLE

AREA INLET PROTECTION

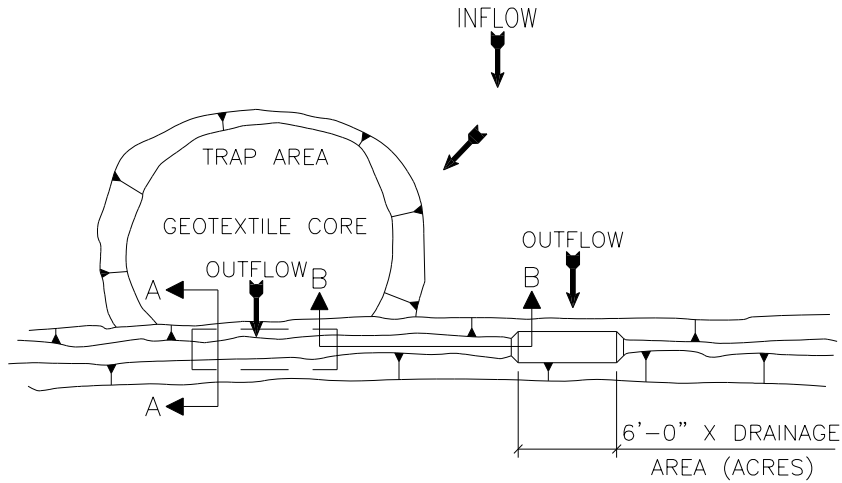

PLAN VIEW

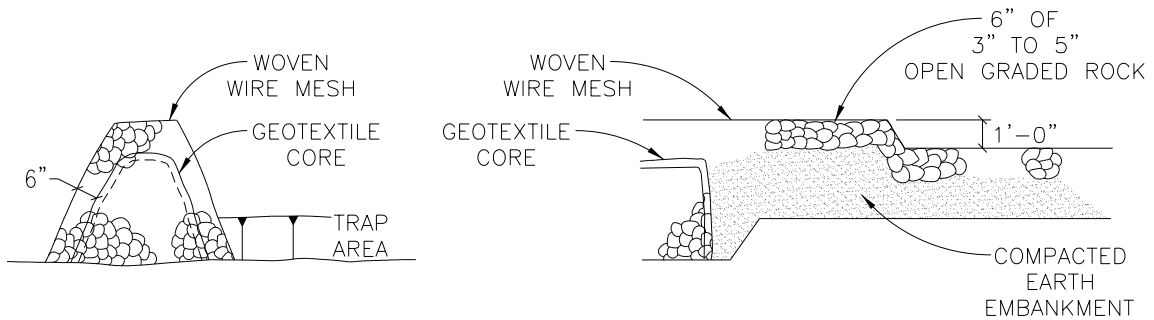

SECTION A-A

SECTION B-B

INSTALLATION:

- LOCATE THE SEDIMENT TRAP SO AS TO DISTURB AS FEW TREES AS POSSIBLE.
- CLEAR AND GRUB THE AREA UNDER THE EMBANKMENT OF ALL VEGETATION AND ROOT MATS.
- LAYOUT THE WIRE MESH AND THEN THE GEOTEXTILE FABRIC.
- CONSTRUCT THE GEOTEXTILE CORE AND CORRESPONDING ROCK EMBANKMENT TO THE DESIGNATED HEIGHT AND CONFIGURATION.
- WRAP THE STRUCTURE WITH THE PREVIOUSLY PLACED WIRE MESH SECURE ENOUGH SO THAT WHEN WALKED ACROSS THE STRUCTURE RETAINS IT'S SHAPE. SECURE WITH TIE WIRE.
- PLACE THE EMBANKMENT MATERIAL IN 8 TO 12 INCH LIFTS AND MACHINE COMPACT.

INSPECTION AND MAINTENANCE GUIDELINES:

- INSPECTION SHOULD BE MADE WEEKLY AND AFTER EACH RAINFALL. CHECK THE EMBANKMENT, SPILLWAYS, AND OUTLET FOR EROSION DAMAGE AND INSPECT THE EMBANKMENT FOR PIPING AND SETTLEMENT. REPAIR SHOULD BE MADE PROMPTLY AS NEEDED BY THE CONTRACTOR.
- TRASH AND OTHER DEBRIS SHOULD BE REMOVED AND THE TRAP RESTORED TO ITS ORIGINAL DIMENSIONS WHEN THE SEDIMENT HAS ACCUMULATED TO HALF OF THE DESIGN DEPTH OF THE TRAP.
- SEDIMENT REMOVED FROM THE TRAP SHOULD BE DEPOSITED IN AN APPROVED SPOILS AREA AND IN SUCH A MANNER THAT IT WILL NOT CAUSE ADDITIONAL SILTATION.

SCALE: NOT TO SCALE



MARBLE FALLS
800 THIRD STREET
MARBLE FALLS, TX 78654
PH: (830) 693-6737

These documents were prepared by,
or under the supervision of:

ERIC BELAJ 107148 May 31, 2017
Engineer's Name PE# Date

Engineer's Signature

SECTION
EROSION CONTROL

DETAIL NO.
EC-9

TITLE
SEDIMENT TRAP

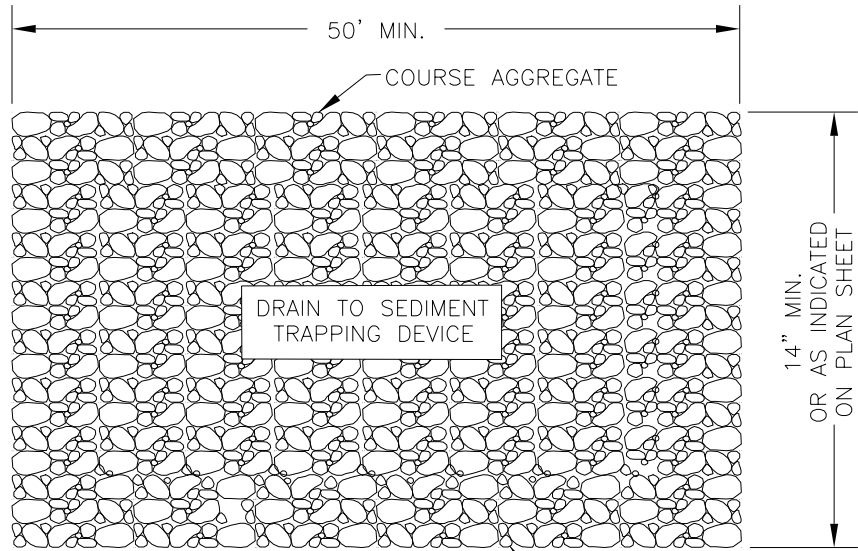

PLAN COURSE AGGREGATE

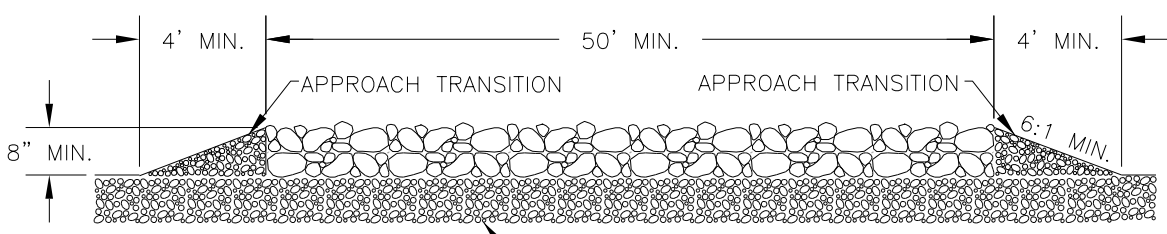

PROFILE

CONSTRUCTION EXIT NOTES:

1. THE LENGTH OF THE ROCK CONSTRUCTION EXIT SHALL BE AS INDICATED ON THE PLANS, BUT NOT LESS THAN 50'.
2. THE COARSE AGGREGATE SHOULD BE OPEN GRADED WITH A SIZE OF 4" TO 8".
3. THE APPROACH TRANSITION SHOULD BE NO STEEPER THAN 6:1.
4. THE CONSTRUCTION EXIT SHALL BE GRADED TO ALLOW FOR POSITIVE DRAINAGE.
5. THE DESIGN DETAILS INDICATED HEREIN SHOULD BE MODIFIED AS NECESSARY TO ENSURE SEDIMENT DOES NOT LEAVE PROJECT SITE.

SCALE: NOT TO SCALE



MARBLE FALLS
 800 THIRD STREET
 MARBLE FALLS, TX 78654
 PH: (830) 693-6737

These documents were prepared by,
 or under the supervision of:

ERIC BELAJ 107148 May 31, 2017
 Engineer's Name PE# Date

Engineer's Signature

SECTION
EROSION CONTROL

DETAIL NO.
EC-10

TITLE
 CONSTRUCTION EXIT

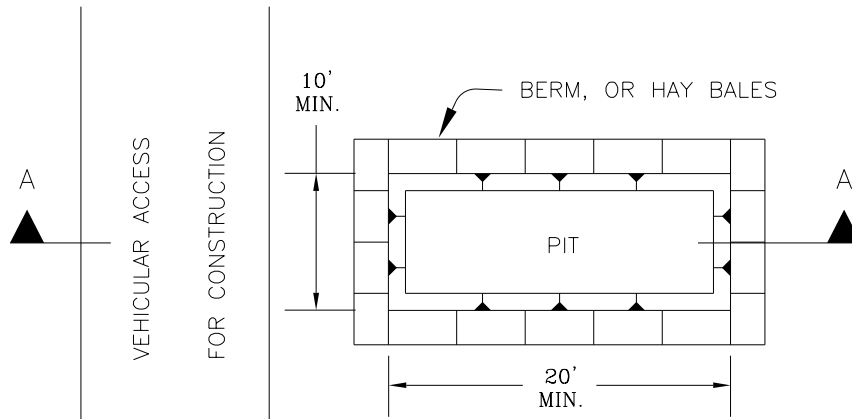

PLAN

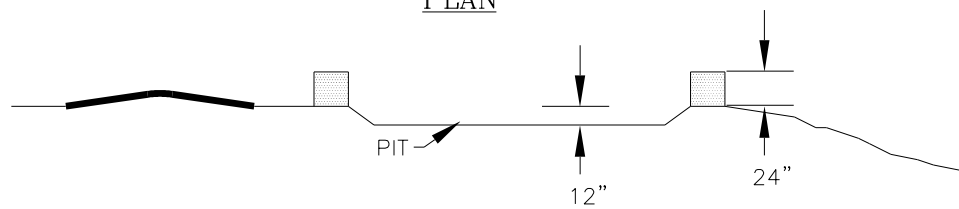

SECTION A-A

CONCRETE WASHOUT NOTES:

1. DETAIL ILLUSTRATES MINIMUM DIMENSIONS. PIT CAN BE INCREASED IN SIZE DEPENDING ON EXPECTED FREQUENCY OF USE.
2. IF HAY BALES ARE USED, THEY SHALL BE PLACED IN ACCORDANCE WITH DETAILS SHOWN ON EXHIBIT FOR HAY BALES.
3. WASHOUT PIT SHALL BE LOCATED IN AN AREA EASILY ACCESSIBLE TO CONSTRUCTION TRAFFIC.
4. WASHOUT PIT SHALL NOT BE LOCATED IN AREAS SUBJECT TO INUNDATION FROM STORM WATER RUNOFF.

SCALE: NOT TO SCALE



MARBLE FALLS
 800 THIRD STREET
 MARBLE FALLS, TX 78654
 PH: (830) 693-6737

These documents were prepared by,
 or under the supervision of:

ERIC BELAJ 107148 May 31, 2017
 Engineer's Name PE# Date



 Engineer's Signature

SECTION
EROSION CONTROL

DETAIL NO.
 EC-11

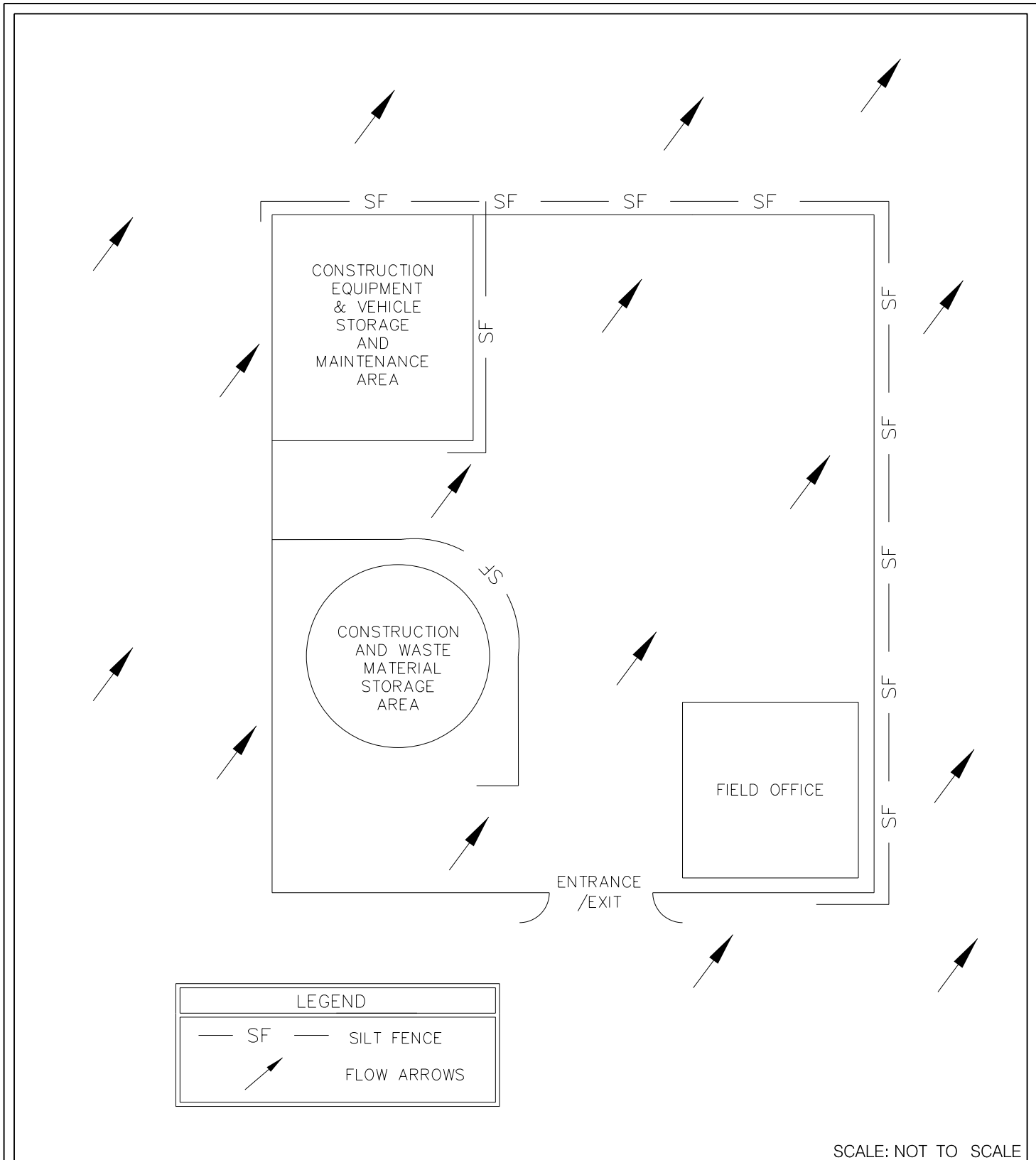
TITLE
 CONCRETE WASHOUT



LEGEND	
— SF —	SILT FENCE
	FLOW ARROWS

SCALE: NOT TO SCALE



MARBLE FALLS
 800 THIRD STREET
 MARBLE FALLS, TX 78654
 PH: (830) 693-6737

These documents were prepared by,
 or under the supervision of:

ERIC BELAJ	107148	May 31, 2017
Engineer's Name	PE#	Date



Engineer's Signature

SECTION	EROSION CONTROL
DETAIL NO.	EC-12
TITLE	CONSTRUCTION STAGING

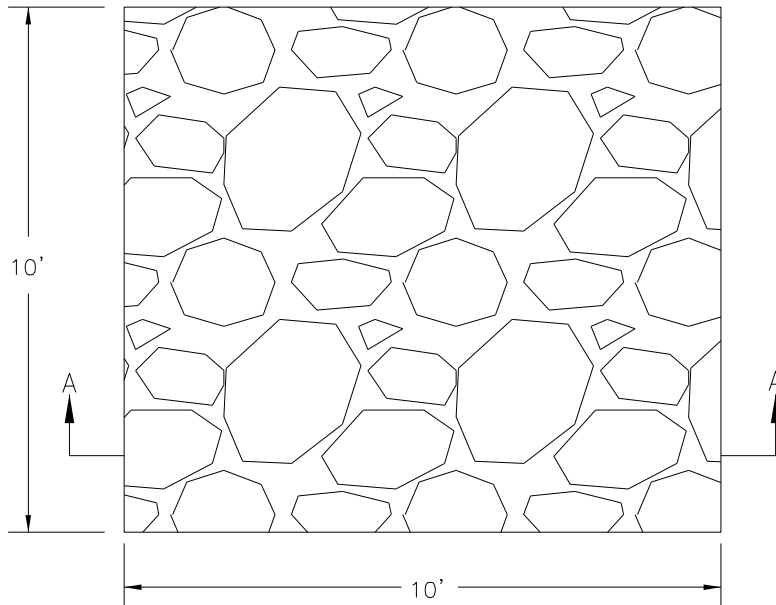

PLAN

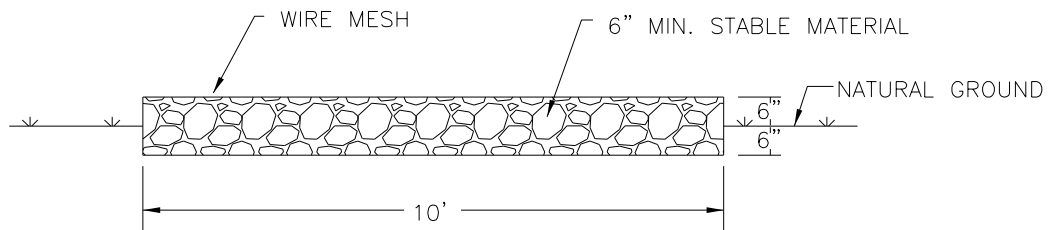

SECTION "A"

SCALE: NOT TO SCALE



MARBLE FALLS
 800 THIRD STREET
 MARBLE FALLS, TX 78654
 PH: (830) 693-6737

These documents were prepared by,
 or under the supervision of:

ERIC BELAJ 107148 May 31, 2017
 Engineer's Name PE# Date

Engineer's Signature

SECTION
EROSION CONTROL

DETAIL NO.
 EC-13

TITLE
 LEVEL SPREADER

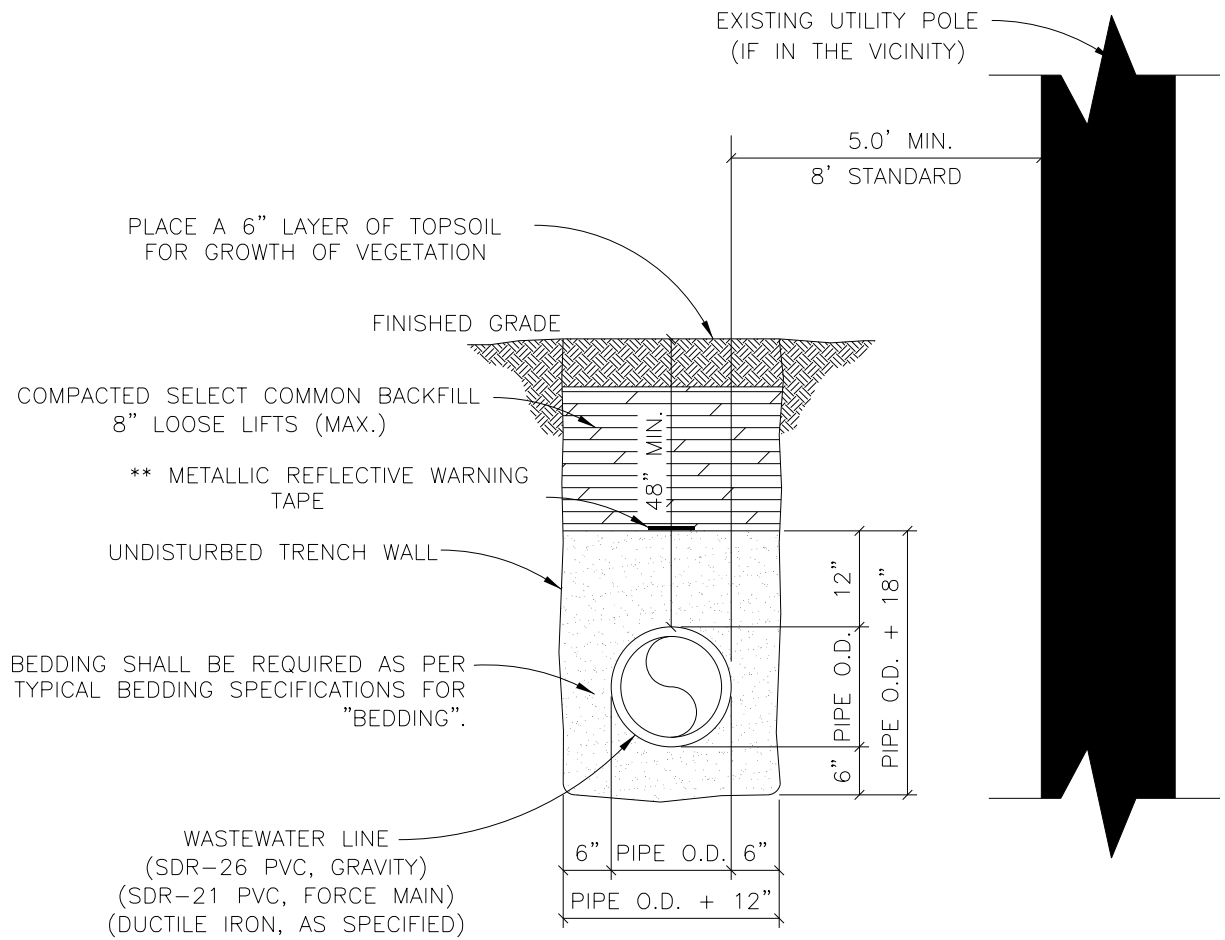

** REFLECTIVE WARNING TAPE SHALL INDICATE "PRESSURIZED WASTEWATER" FOR PRESSURE LINES IN AT LEAST 1.5" LETTERS CONTINUOUSLY REPEATED. REFLECTIVE WARNING TAPE SHALL INDICATE "BURIED SEWER LINE BELOW" FOR GRAVITY SEWER LINES.

SCALE: NOT TO SCALE



MARBLE FALLS
800 THIRD STREET
MARBLE FALLS, TX 78654
PH: (830) 693-6737

These documents were prepared by,
or under the supervision of:

ERIC BELAJ 107148 May 31, 2017
Engineer's Name PE# Date

Engineer's Signature

SECTION

WASTEWATER

DETAIL NO.

WW-1

TITLE

EMBEMENT UNDER
UNPAVED AREAS

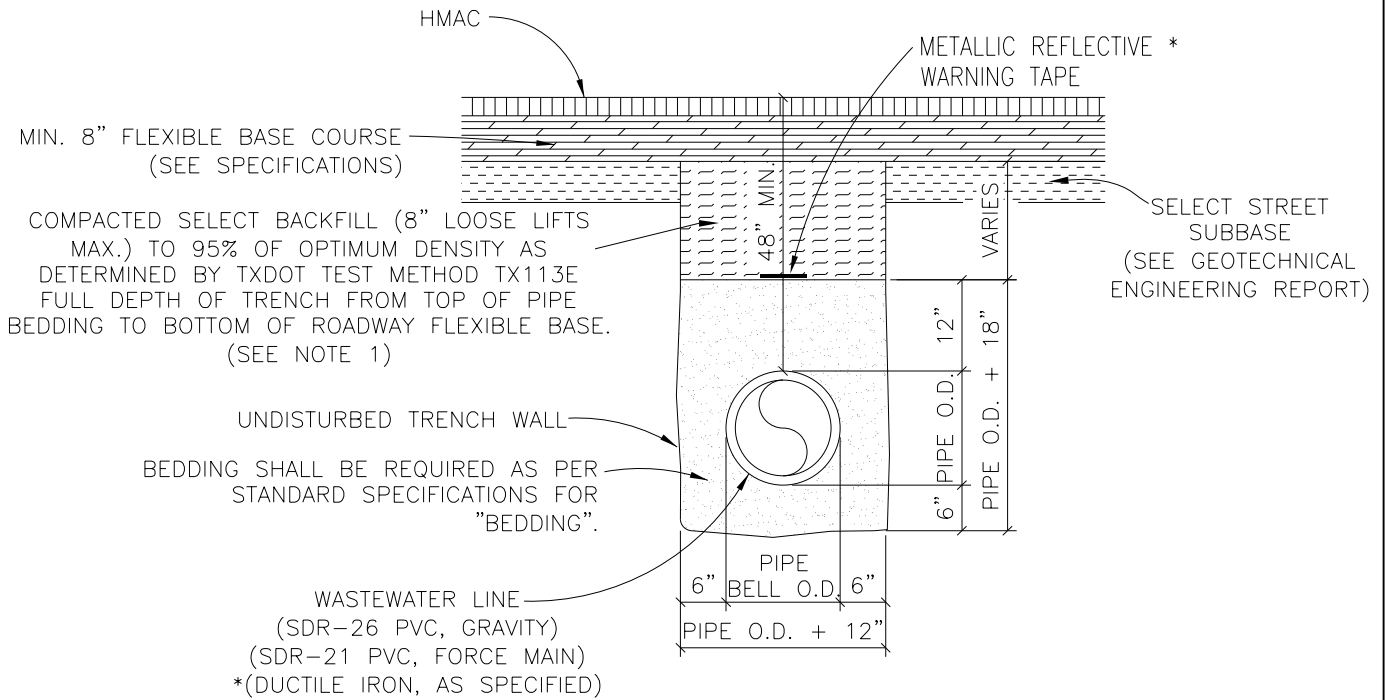

NOTES:

1. A MINIMUM OF ONE DENSITY TEST SHALL BE TAKEN EVERY TWO HUNDRED (200) FEET FOR EACH EIGHT (8) INCH LOOSE LIFT OF SELECT BACKFILL. PROCTORS FOR MATERIALS USED IN BACKFILLING SHALL BE OBTAINED BY A CERTIFIED LABORATORY. DENSITY TESTS SHALL BE CONDUCTED BY A CERTIFIED LABORATORY OR THE PERMITTEE'S CONSULTANTS. ALL DENSITY TESTS SHALL BE COMPLETED AND ACCEPTED ON EACH LAYER PRIOR TO ADDITIONAL BACKFILLING. A COPY OF ALL COMPLETED AND ACCEPTED DENSITY TESTS SHALL BE FURNISHED TO THE OWNER. BACKFILL COMPACTION SHALL BE A MINIMUM 95% OF OPTIMUM DENSITY AS DETERMINED BY TXDOT 113E TEST METHOD.
 2. CONTRACTOR OR ENGINEER MAY REQUEST FOR USE OF ALTERNATE BACKFILL MATERIAL. ALTERNATE MATERIALS AND TESTING PROTOCOL MUST BE SUBMITTED TO AND APPROVED BY THE CITY ENGINEER PRIOR TO USE.
 3. REFER TO GEOTECHNICAL REPORT FOR ADDITIONAL SUBGRADE, FLEXIBLE BASE AND PAVEMENT REQUIREMENTS.
- * REFLECTIVE WARNING TAPE SHALL INDICATE "PRESSURIZED WASTEWATER" FOR PRESSURE LINES IN AT LEAST 1.5" LETTERS CONTINUOUSLY REPEATED. REFLECTIVE WARNING TAPE SHALL INDICATE "BURIED SEWER LINE BELOW" FOR GRAVITY SEWER LINES.
- * THIS DETAIL HAS BEEN MODIFIED TO INCLUDE DUCTILE IRON PIPE.

SCALE: NOT TO SCALE



MARBLE FALLS
800 THIRD STREET
MARBLE FALLS, TX 78654
PH: (830) 693-6737

These documents were prepared by,
or under the supervision of:

ERIC BELAJ 107148 May 31, 2017
Engineer's Name PE# Date

Engineer's Signature

SECTION
WASTEWATER

DETAIL NO.
WW-2

TITLE
EMBEDMENT UNDER
PROPOSED PAVEMENT

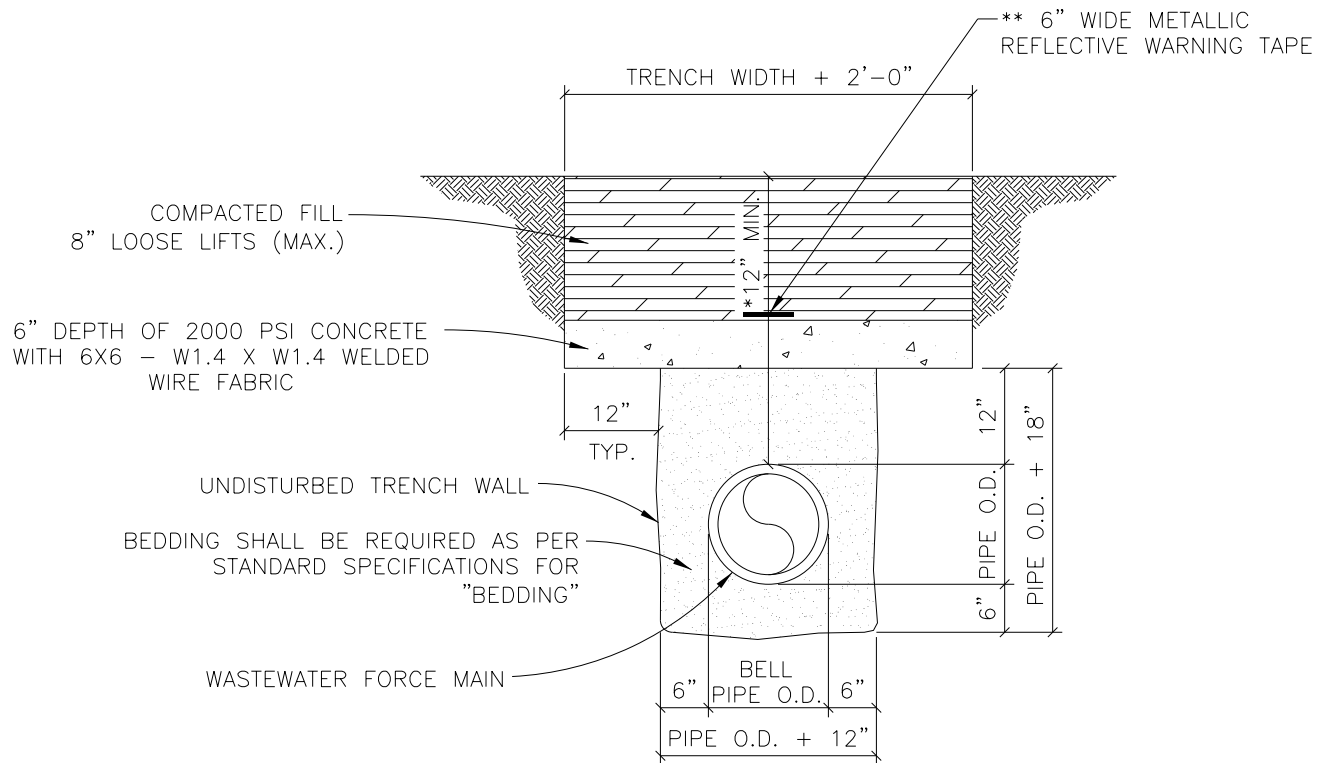

* WHERE 48" MINIMUM COVER CAN NOT BE OBTAINED OR DUE TO POTENTIAL SURFACE LOADING THE CITY MAY REQUIRE A CAP TO BE INSTALLED.

** REFLECTIVE WARNING TAPE SHALL INDICATE "PRESSURIZED WASTEWATER" FOR PRESSURE LINES IN AT LEAST 1.5" LETTERS CONTINUOUSLY REPEATED. REFLECTIVE WARNING TAPE SHALL INDICATE "BURIED SEWER LINE BELOW" FOR GRAVITY SEWER LINES.

SCALE: NOT TO SCALE



MARBLE FALLS
800 THIRD STREET
MARBLE FALLS, TX 78654
PH: (830) 693-6737

These documents were prepared by,
or under the supervision of:

ERIC BELAJ 107148 May 31, 2017
Engineer's Name PE# Date

Engineer's Signature

SECTION

WASTEWATER

DETAIL NO.

WW-4

TITLE

CONCRETE CAP
EMBEDMENT

M.F.G. PER ASTM-C478
 5000 P.S.I. CONCRETE
 TRAFFIC BEARING
 O-RING JOINT PER C443

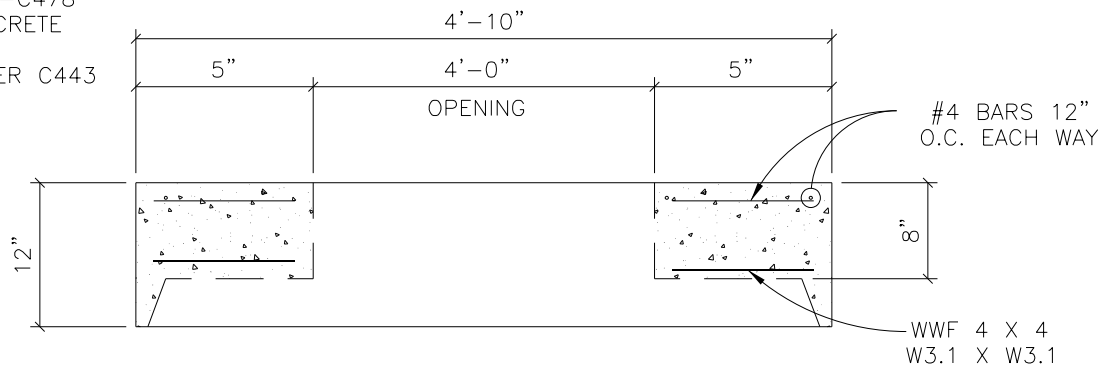

NOTES:

1. AVAILABLE WITH CAST IRON RING AND COVER CAST IN PLACE.
2. PERMITTED ONLY WITH WRITTEN APPROVAL FROM CITY OF MARBLE FALLS

SCALE: NOT TO SCALE



MARBLE FALLS
 800 THIRD STREET
 MARBLE FALLS, TX 78654
 PH: (830) 693-6737

These documents were prepared by,
 or under the supervision of:

ERIC BELAJ 107148 May 31, 2017
 Engineer's Name PE# Date

Engineer's Signature

SECTION
WASTEWATER

DETAIL NO.
 WW-5

TITLE
 STANDARD 48"
 FLAT LID MANHOLE

A	B	C	D	E
4"	9"	11 1/8"	12 1/4"	4 3/4"

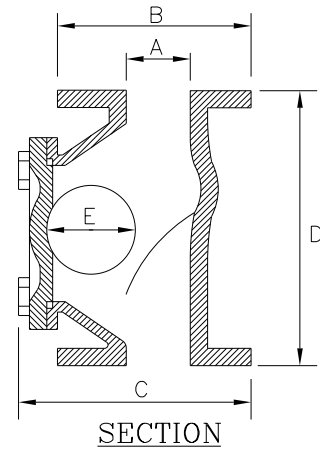

FLOMATIC MODEL 408F BALL CHECK VALVE

SCALE: N.T.S.
(SEE NOTE 4 BELOW)

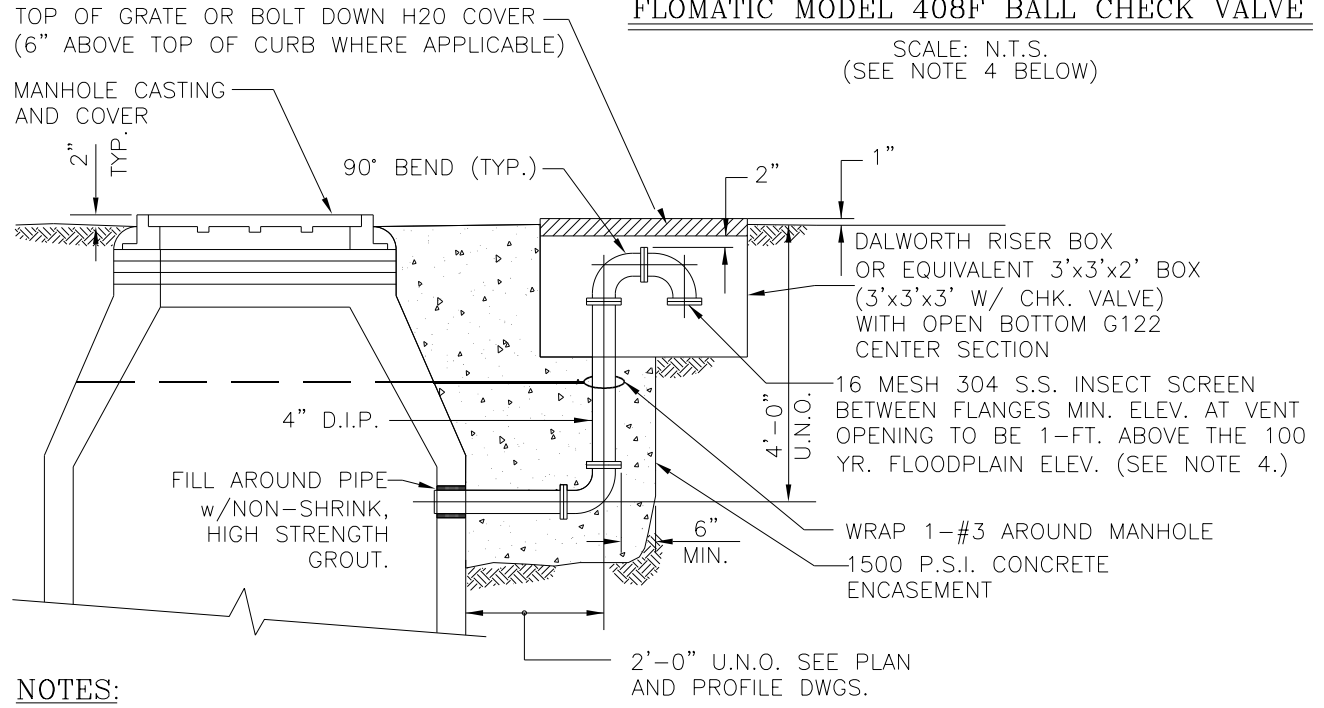

- NOTES:**
- AIR INTAKE PIPE TO BE D.I.P., CLASS 53 WITH FLANGED CONNECTIONS.
 - ALL FITTINGS TO BE 150 PSIG RATED & ANSI/AWWA C110/A21.10.
 - SURFACE PREP ABOVE GROUND PIPING TO SSPC10-63, N.A.C.E. NO.2 STANDARD. APPLY EPOXY PRIMER 2-4 MIL, DFT FOLLOWED BY 2 COATS OF AMINE ADDUCT CURED, HIGH-BUILD EPOXY (TWO COMPONENT EPOXY POLYAMIDE) 8-10 MIL DFT, NON-LEAD CEDAR GREEN COLOR.
 - IF ELEVATION OF VENT OPENING IS LESS THAN 1-FT. ABOVE 100 YR. FLOODPLAIN, FLOMATIC MODEL 408F BALL CHECK VALVE OR EQUAL WITH FLOATING TYPE BALL TO BE INSTALLED AT DOWNTURNED OPENING OF VENT. (SEE DIMENSIONAL DETAIL ABOVE RIGHT). 16 MESH 304 S.S. INSECT SCREEN TO BE PLACED IN THE OPENING.

SCALE: NOT TO SCALE



MARBLE FALLS
800 THIRD STREET
MARBLE FALLS, TX 78654
PH: (830) 693-6737

These documents were prepared by,
or under the supervision of:

ERIC BELAJ 107148 May 31, 2017
Engineer's Name PE# Date

[Signature]
Engineer's Signature

SECTION
WASTEWATER

DETAIL NO.
WW-6

TITLE
MANHOLE VENT

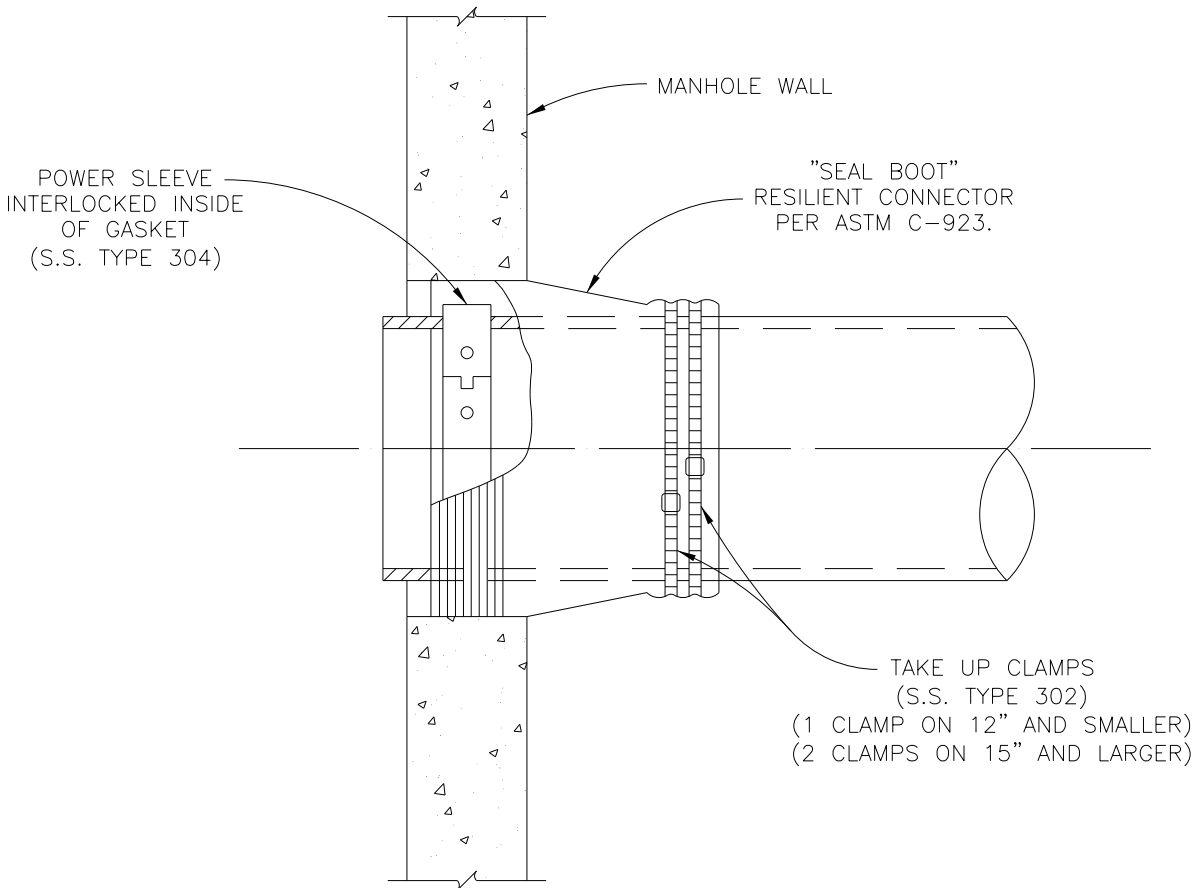

SCALE: NOT TO SCALE



MARBLE FALLS
800 THIRD STREET
MARBLE FALLS, TX 78654
PH: (830) 693-6737

These documents were prepared by,
or under the supervision of:

ERIC BELAJ 107148 May 31, 2017
Engineer's Name PE# Date

Engineer's Signature

SECTION
WASTEWATER

DETAIL NO.
WW-7

TITLE
FLEX SEAL BOOT
CONNECTION

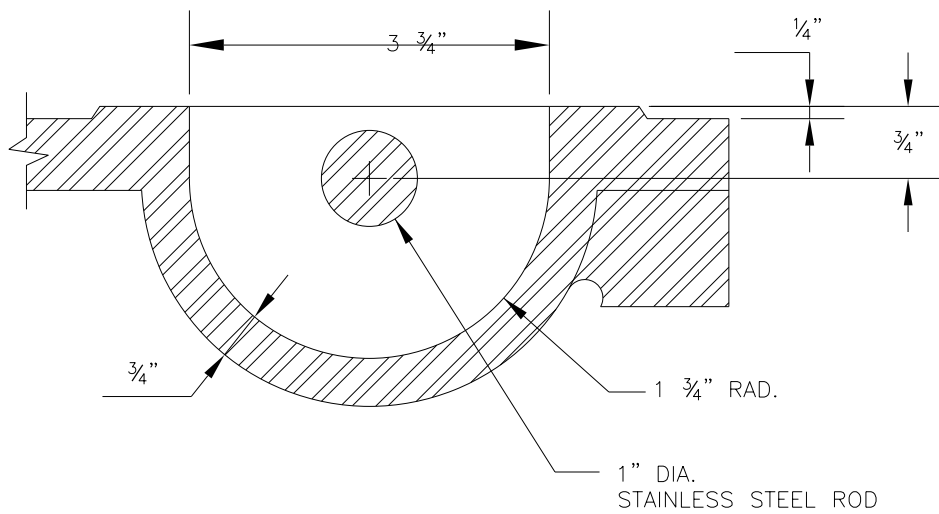
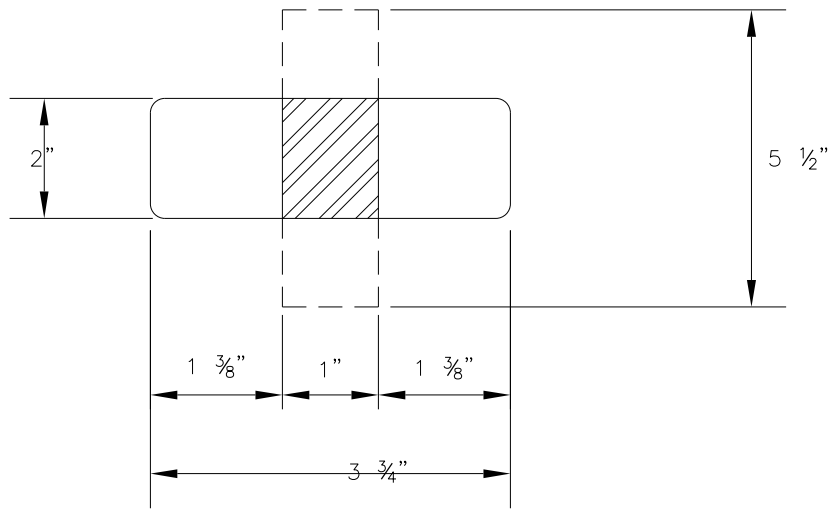

SCALE: NOT TO SCALE



MARBLE FALLS
 800 THIRD STREET
 MARBLE FALLS, TX 78654
 PH: (830) 693-6737

These documents were prepared by,
 or under the supervision of:

ERIC BELAJ 107148 May 31, 2017
 Engineer's Name PE# Date

 Engineer's Signature

SECTION
WASTEWATER

DETAIL NO.
 WW-8

TITLE
 TYPE 4 PICKBAR

GASKETED SEWER FITTING
NO. 52635 (6") AS
MANUFACTURED BY
VASSALLO, INC. OR
APPROVED EQUAL

PVC SERVICE
SDR-26 OR
SCH-40

1/8 BEND-SPIGOT

PVC SERVICE
SDR-26 OR
SCH-40

SADDLE TEE

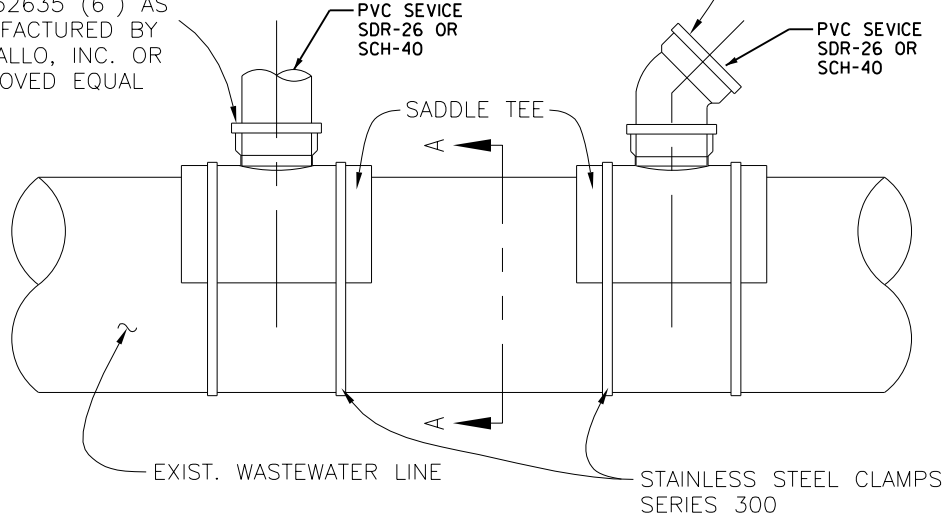

PLAN VIEW

SADDLE TEE				
PART NO.	SIZE	L1	H	P
52635	8"x6"	5.625	5.659	1.448

PLASTIC TRENDS INC. - 1/8 BEND - SPIGOT					
PART NO.	SIZE	A	B	C	D
G 406	6	11.270	6.146	1.870	6.090

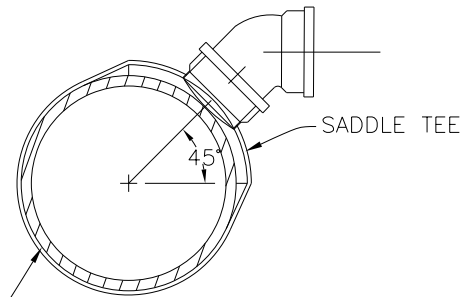

EXIST. WW LINE

SECTION A-A

NOTES:

1. FLEXIBLE SADDLE TO BE INSTALLED IN ACCORDANCE WITH MANUFACTURER'S REQUIREMENTS.
2. SADDLE TEE SHALL BE ORIENTATED 45°D TO MAIN. (SEE SEWER SERVICE CONNECTIONS DETAIL).
3. EXCAVATE AROUND EXISTING 8-INCH PIPE, EXPOSING SUFFICIENT ROOM FOR S.S. CLAMPS.
4. THOROUGHLY CLEAN AND DRY THE MATING SURFACE WITH RAG OR PAPER TOWEL MAKE SURE THEY ARE FREE OF DUST AND MOISTURE.
5. MARK THE SIZE OF THE HOLE TO BE CUT USING THE GASKET SKIRT OR THE SADDLE ITSELF AS THE TEMPLATE.
6. SAW OUT THE SECTION OF THE PIPE WHERE THE SADDLE WILL BE LOCATED, WITH A SABER, KEY HOLE SAW, OR CORE DRILL.
7. TEST TO MAKE SURE SADDLE FITS HOLE PROPERLY.
8. SERVICE PIPE SHALL NOT EXTEND MORE THAN ONE-HALF INCH INTO THE MAIN.
9. PLACE GASKET SKIRT AND SADDLE OVER OPENING AND TIGHTEN BAND CLAMPS EVENLY UNTIL SADDLE IS FIRMLY ATTACHED TO THE PIPE. APPLY PRESSURE ON THE SADDLE AGAINST THE PIPE WHILE TIGHTENING THE CLAMPS AS INDICATED ABOVE. DO NOT OVER TIGHTEN, DO NOT STRIP THREAD.
10. REPLACE THE BEDDING AND BACKFILL IN ACCORDANCE WITH THE TRENCH EMBEDMENT DETAIL.
11. THE SERVICE LINE SHALL BE MINIMUM SDR-26 (GREEN), OR SCH-40.

SCALE: NOT TO SCALE



MARBLE FALLS

800 THIRD STREET
MARBLE FALLS, TX 78654

PH: (830) 693-6737

These documents were prepared by,
or under the supervision of:

ERIC BELAJ 107148 May 31, 2017
Engineer's Name PE# Date

Engineer's Signature

SECTION

WASTEWATER

DETAIL NO.

WW-9

TITLE

SERVICE CONNECTION
TO EXISTING LINES

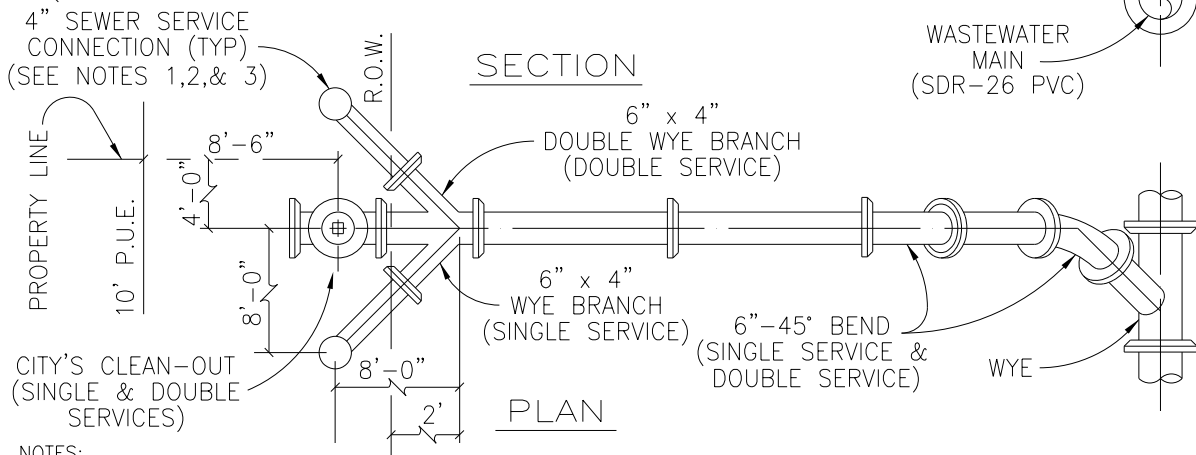
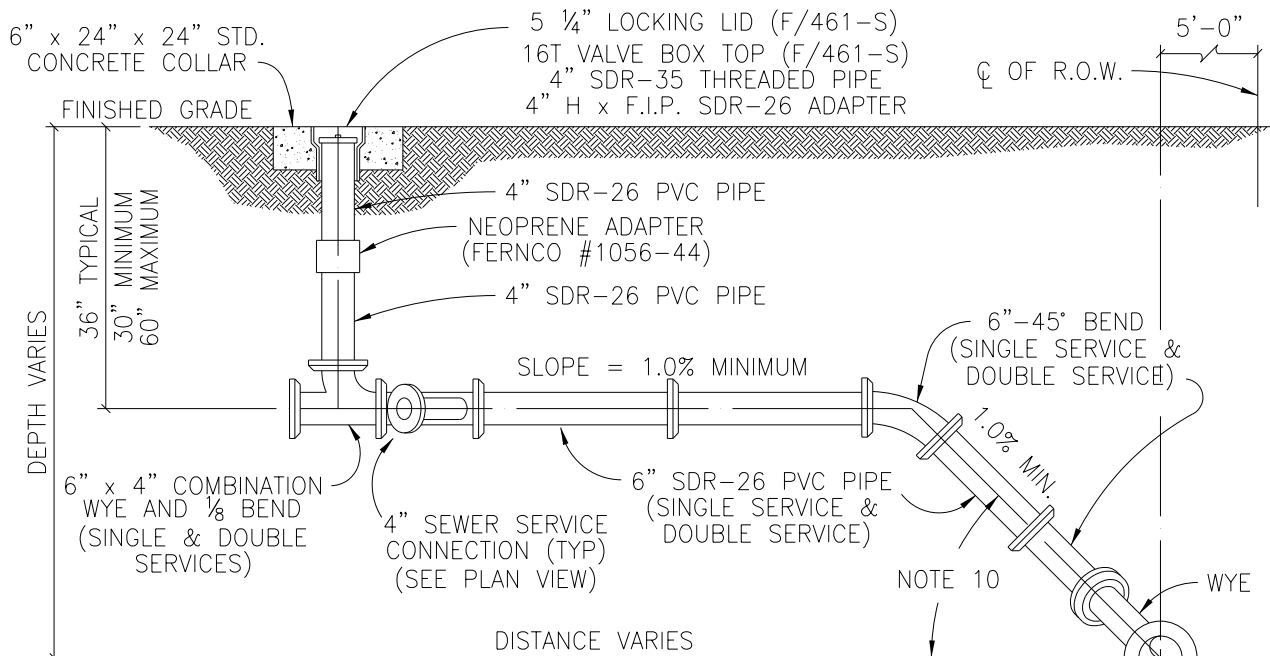

NOTES:

1. SERVICE CONNECTION RISERS SHALL TERMINATE 6' INSIDE THE PROPERTY LINE.
2. THE END OF EACH SERVICE CONNECTION RISER SHALL BE EXTENDED 12" ABOVE FINISH GRADE.
3. EACH SERVICE CONNECTION SHALL BE PLUGGED WATER-TIGHT WITH AN APPROVED CAP OR PLUG.
4. CUT OFF BELL END WHEN USING FERCO COUPLING FOR V.C.P. (FOR EXISTING SERVICES ONLY).
5. FOR P.V.C. INSTALLATIONS, CONNECT TO EXISTING "BELL END" AND CONNECT OPPOSITE END WITH P.V.C. TO P.V.C. KNOCK ON SLEEVE.
6. SOLIDLY TAMP BACKFILL AT LEAST ONE FOOT (1'-0") ABOVE TOP OF PIPE. SERVICES UNDER PAVED AREAS SHALL BE BACKFILLED TO THE SAME SPECIFICATIONS AS SHOWN ON PAVEMENT REPLACEMENT DETAIL.
7. CONTRACTOR SHALL MARK ON A CLEAN SET OF PLANS THE FINAL STATIONING OR DISTANCE AND DIRECTION FROM MANHOLE TO EACH SERVICE LATERAL AND GIVE TO ENGINEER FOR RECORD DRAWING PURPOSES.
8. ANY DEVIATION FROM THESE METHODS SHOULD BE APPROVED BY THE CITY OF MARBLE FALLS PUBLIC WORKS DEPARTMENT.
9. SERVICE LINE MATERIAL SHALL BE P.V.C., SDR-26.
10. SEWER SERVICE SLOPE TO BE 45° OFF THE MAIN PIPE CENTERLINE
11. ALL NON-RESIDENTIAL SERVICE LINES 6" OR GREATER MUST DISCHARGE TO A NEW MANHOLE ON THE MAIN PIPE.
12. ALL NON-RESIDENTIAL DOUBLE SERVICE LINES SHALL BE 8" OR LARGER.

SCALE: NOT TO SCALE



MARBLE FALLS
800 THIRD STREET
MARBLE FALLS, TX 78654
PH: (830) 693-6737

These documents were prepared by,
or under the supervision of:

ERIC BELAJ 107148 May 31, 2017
Engineer's Name PE# Date

Engineer's Signature

SECTION
WASTEWATER

DETAIL NO.
WW-10

TITLE
SERVICE LINE

STANDARD CASTING AND COVER, AS SPECIFIED.
(BOLTED WHEN INDICATED ON PLANS)

* MAXIMUM MANHOLE SPACING	
PIPE DIAMETER (IN)	MAXIMUM MANHOLE SPACING (FEET)
6 - 15	500
18 - 30	800
36 - 48	1000
54 OR LARGER	2000

* SEE TCEQ CHAPTER 217 FOR ADDITIONAL
MANHOLE LOCATION REQUIREMENTS.

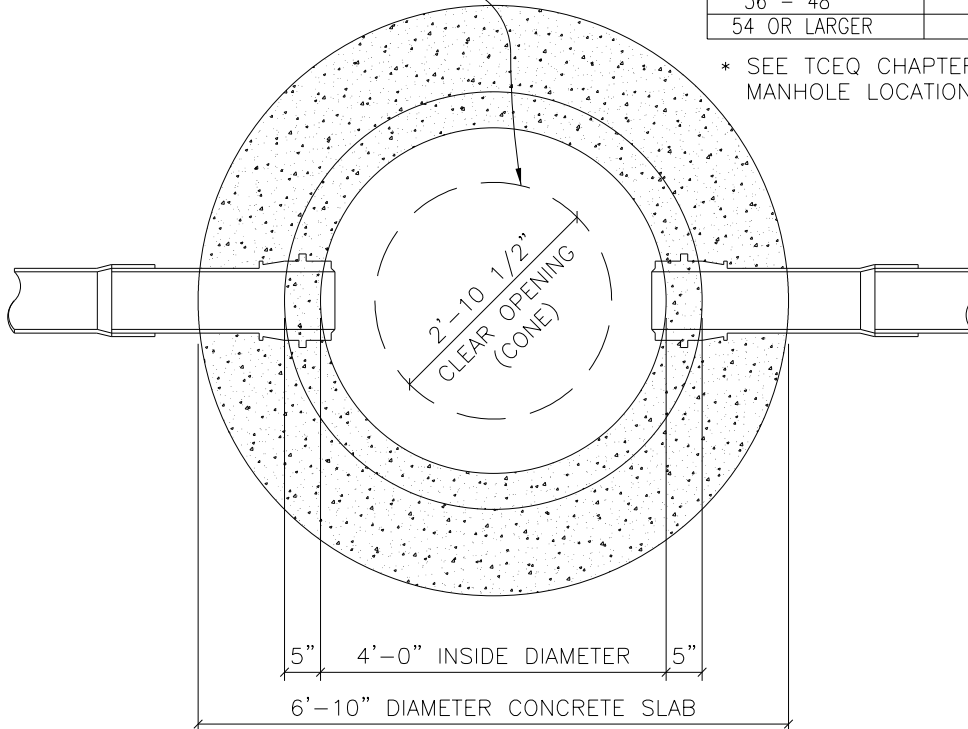

MANHOLE PLAN

NOTES:

MANHOLE DETAILS SHALL REFLECT THE CITY'S MINIMUM SPECIFICATIONS, AS STATED BELOW:

- A. ALL MANHOLES SHALL BE 48" I.D., R.C.P., CLASS III, WITH RUBBER O-RING GASKET JOINTS CONFORMING TO ASTM C478, C433 AND C76.
- B. ALL MANHOLES SHALL HAVE WATER-TIGHT FRAME AND COVER, WITH A MINIMUM 30" CLEAR OPENING, AS MANUFACTURED BY EAST JORDAN IRON WORKS (AS PER CONCRETE APRON AROUND MANHOLE RING & COVER DETAIL) OR APPROVED EQUAL.
- C. ALL MANHOLES SHALL BE CONCRETE WITH CAST IRON FRAME AND BOLTED COVER.
- D. ALL MANHOLES SHALL HAVE A CONCENTRIC LID.
- E. MANHOLES MAY HAVE A FLAT LID, IF APPROVED BY CITY OF MARBLE FALLS, BEING 12" THICK WITH A MINIMUM 30" OPENING, AS MANUFACTURED BY CALVERT CONCRETE OR APPROVED EQUAL M.F.G. CONFORMING TO ASTM C478, 5000 P.S.I. CONCRETE, TRAFFIC BEARING, AND O-RING JOINT CONFORMING TO ASTM C443.
- F. INVERTS AND FLEXIBLE SEAL BOOTS, PER ASTM C-923, SHALL BE CAST INTO BASE SECTION.
- G. MINIMUM DROP BETWEEN INVERTS SHALL BE ONE-TENTH OF A FOOT (0.1').
- H. TWO (2") INCH GRADE RINGS WITH AN I.D. TO MATCH FRAMES CLEAR OPENING, MINIMUM OF TWO (2), MAXIMUM OF FIVE (5) GRADE RINGS REQUIRED.
- I. ALL MANHOLES SHALL COMPLY WITH AND BE TESTED IN ACCORDANCE WITH CURRENT TCEQ REGULATIONS.

SCALE: NOT TO SCALE



MARBLE FALLS
800 THIRD STREET
MARBLE FALLS, TX 78654
PH: (830) 693-6737

These documents were prepared by,
or under the supervision of:

ERIC BELAJ 107148 May 31, 2017
Engineer's Name PE# Date

Engineer's Signature

SECTION
WASTEWATER

DETAIL NO.
WW-11

TITLE
STANDARD MANHOLE PLAN

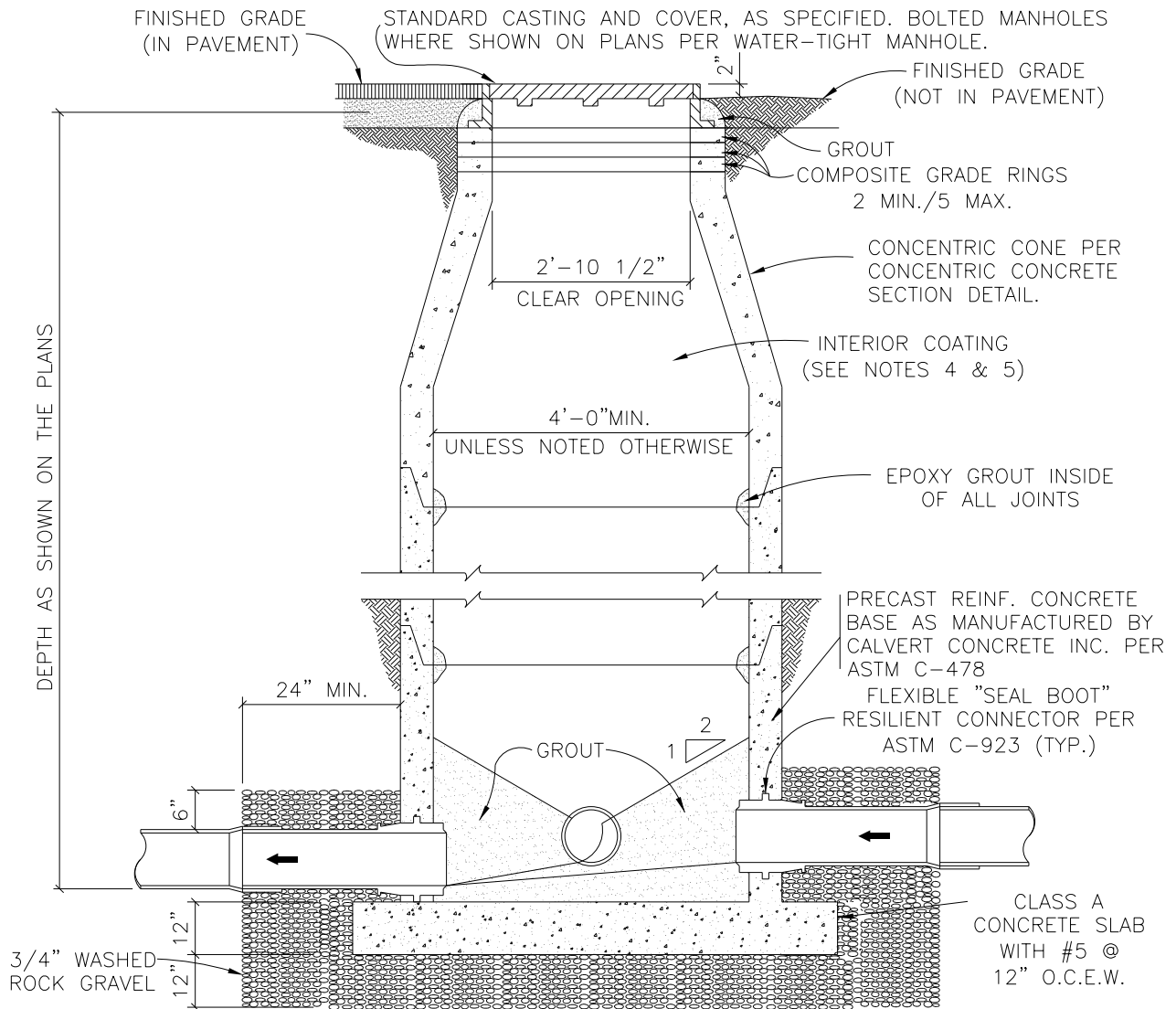

NOTES:

1. MANHOLES SHALL BE PRECAST ASTM C-478 BELL AND SPIGOT WITH "O" RING JOINTS.
2. SEE PLANS & MANHOLE SCHEDULE, FOR MANHOLE SIZE, LOCATION, CONFIGURATION, TYPE OF TOP SECTION, VENTING REQUIREMENTS, PIPE SIZE AND TYPES.
3. SEE SPECIFICATIONS ON MATERIALS AND CONSTRUCTION.
4. ENTIRE INTERIOR OF WASTEWATER MANHOLES AND UNDERSIDE OF FLAT TOPS TO BE "POLIBRID" COATED: 5 MIL DFT POLIBRID 672 PRIMER AND 75 MIL DFT POLIBRID 705 TOPCOAT.
5. AN 80 MIL COAT OF FOSROC EPOXY LINER HBS IS EQUIVALENT TO THE POLIBRID PRIMER / TOPCOAT.
6. ALL MANHOLE COVERS SHALL BE BOLTED AND GASKETED WHEN MANHOLES LOCATED OUTSIDE OF PAVEMENT.
7. MANHOLES TO BE VENTED ARE IDENTIFIED ON MANHOLE SCHEDULE. REFERENCE MANHOLE VENT DETAIL.
8. MANHOLES TO BE DESIGNED TO RESIST LATERAL AND VERTICAL SOIL FORCES RESULTING FROM MANHOLE DEPTH. ADDITIONALLY, MANHOLES LOCATED IN PAVEMENT TO BE DESIGNED FOR HS-20 TRAFFIC LOADS.
9. MANHOLES LOCATED IN PAVEMENT SHALL HAVE BACKFILL COMPACTED TO 95% OF OPTIMUM AS DETERMINED BY TXDOT TEST METHOD TX114E. DENSITY REPORTS SHALL BE PROVIDED TO CITY FOR CERTIFICATION. AS AN ALTERNATIVE FLOWABLE FILL MATERIAL HAVING A STRENGTH F'_c RANGING FROM 300 TO 500 PSI MAY BE USED FOR BACKFILL.
10. COMPOSITE RINGS SHALL BE RUBBER COMPOSITE RISERS MANUFACTURED BY INFRA-RISER.

SCALE: NOT TO SCALE



MARBLE FALLS
 800 THIRD STREET
 MARBLE FALLS, TX 78654
 PH: (830) 693-6737

These documents were prepared by,
 or under the supervision of:

ERIC BELAJ 107148 May 31, 2017
 Engineer's Name PE# Date

[Handwritten Signature]
 Engineer's Signature

SECTION
WASTEWATER

DETAIL NO.
WW-12

TITLE
 STANDARD MANHOLE
 SECTION

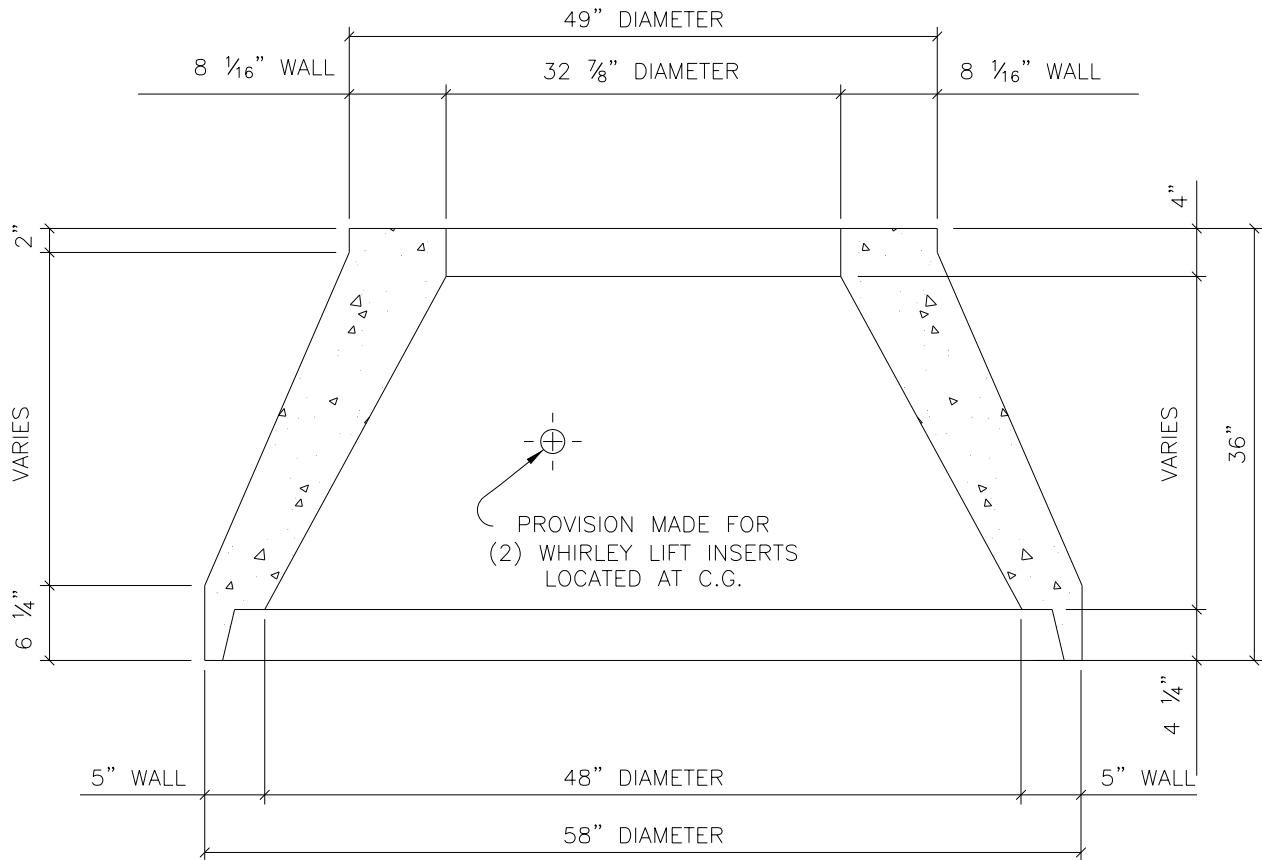

IF ANY, COMPOSITE RINGS SHALL BE RUBBER COMPOSITE RISERS MANUFACTURED BY INFRA-RISER.

SCALE: NOT TO SCALE



MARBLE FALLS
800 THIRD STREET
MARBLE FALLS, TX 78654
PH: (830) 693-6737

These documents were prepared by,
or under the supervision of:

ERIC BELAJ 107148 May 31, 2017
Engineer's Name PE# Date

Engineer's Signature

SECTION
WASTEWATER

DETAIL NO.
WW-13

TITLE
CONCENTRIC TOP
SECTION

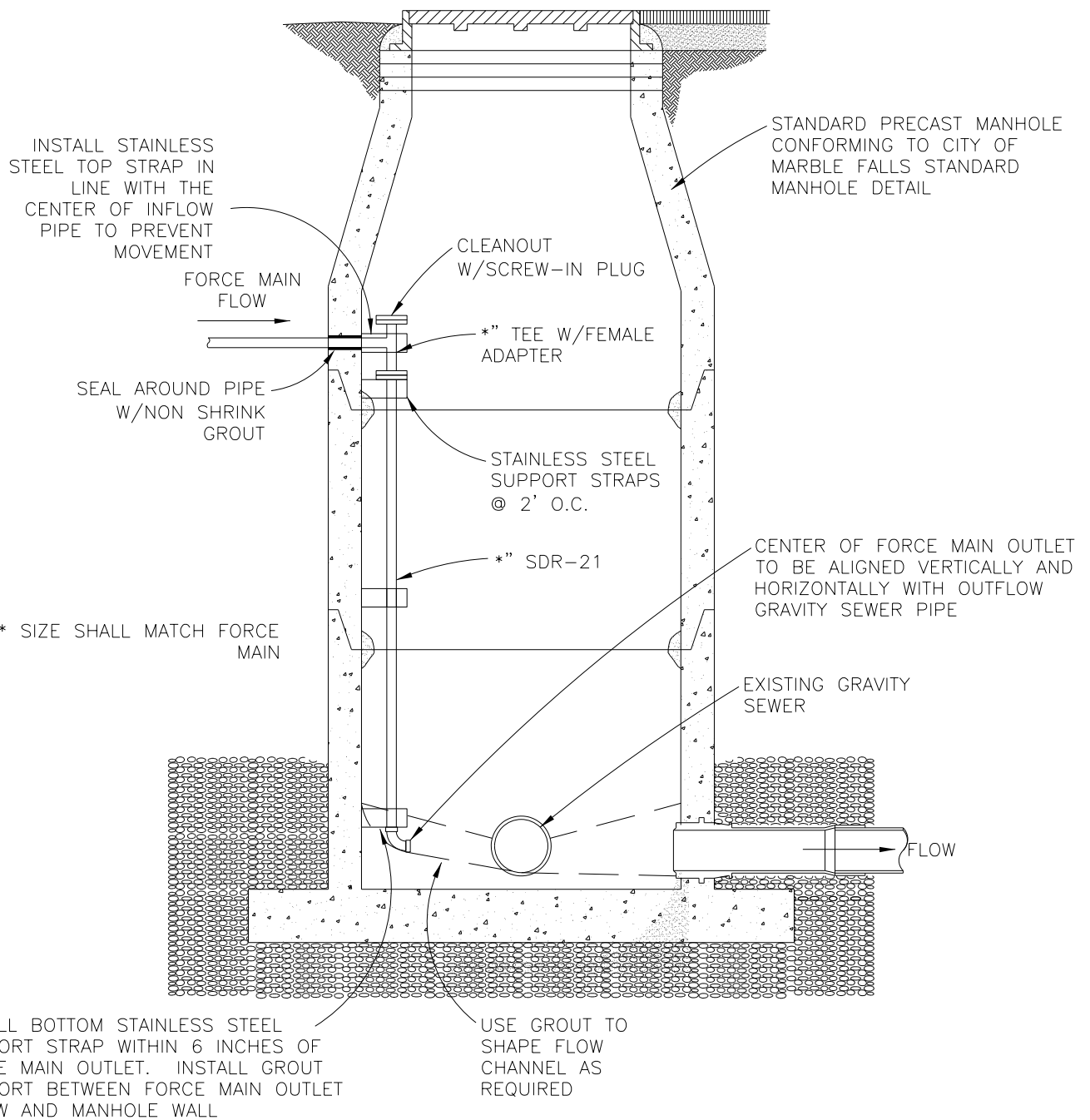

SCALE: NOT TO SCALE



MARBLE FALLS
 800 THIRD STREET
 MARBLE FALLS, TX 78654
 PH: (830) 693-6737

These documents were prepared by,
 or under the supervision of:

ERIC BELAJ 107148 May 31, 2017
 Engineer's Name PE# Date

Engineer's Signature

SECTION

WASTEWATER

DETAIL NO.

WW-14

TITLE

FORCE MAIN CONNECTION
 TO EXISTING MANHOLE

FINISHED GRADE
(IN PAVEMENT)

FINISHED GRADE
(NOT IN PAVEMENT)

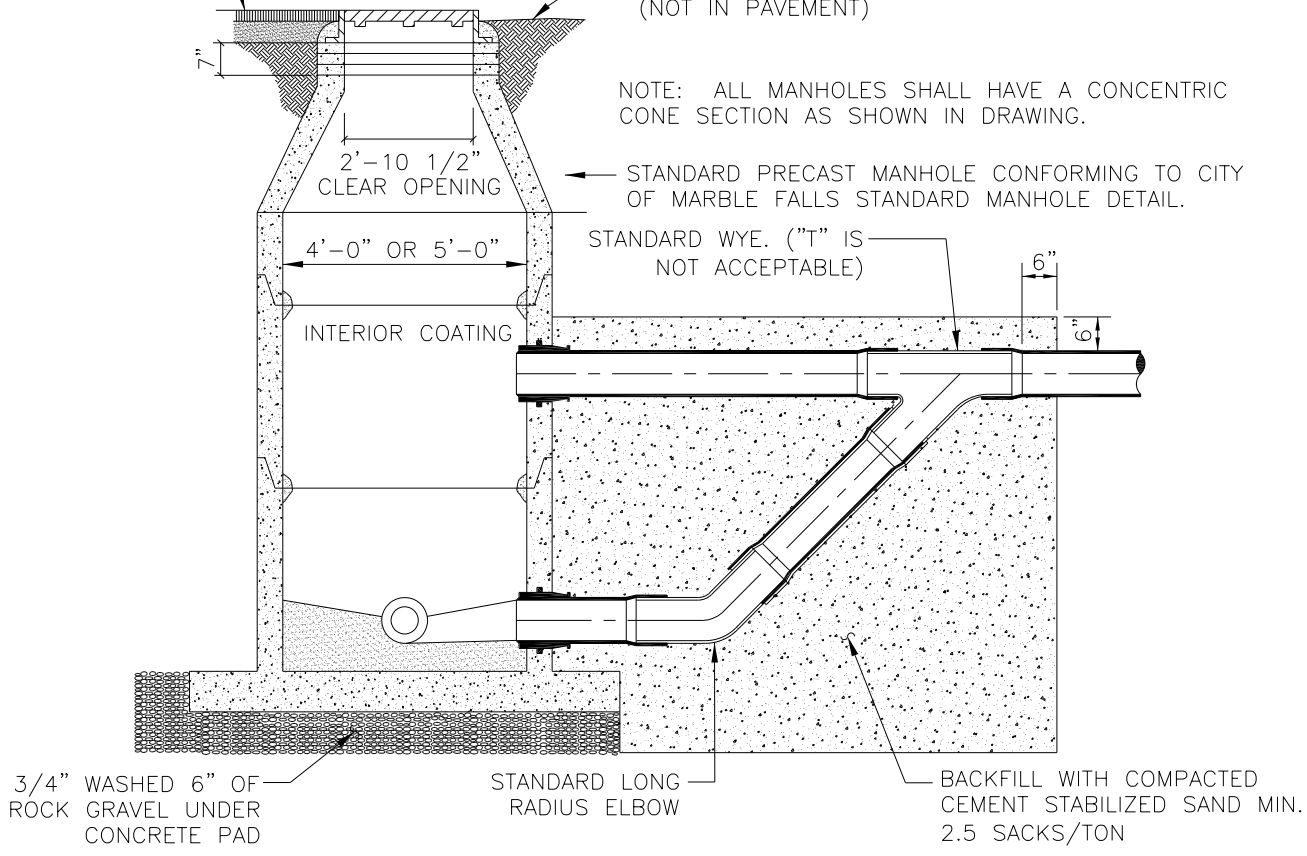

NOTES:

1. DROP CONNECTIONS SHALL BE REQUIRED WHENEVER AN INFLUENT SEWER IS LOCATED TWO (2') OR MORE ABOVE THE MAIN INVERT CHANNEL.
2. A FLOW CHANNEL SHALL BE CONSTRUCTED INSIDE MANHOLE TO DIRECT INFLUENT INTO THE FLOW STREAM.
3. WHEN P.V.C. IS USED IN SANITARY SEWER LINES, SOLVENT TYPE JOINT P.V.C. FITTINGS MAY BE UTILIZED IN THE DROP ASSEMBLY ONLY.
4. MINIMUM PIPE SIZE FOR DROP IS EIGHT INCHES (8").
5. SEE STANDARD DETAIL (STANDARD MANHOLE SECTION) FOR ADDITIONAL REQUIREMENTS.

SCALE: NOT TO SCALE



MARBLE FALLS
 800 THIRD STREET
 MARBLE FALLS, TX 78654
 PH: (830) 693-6737

These documents were prepared by,
or under the supervision of:

ERIC BELAJ 107148 May 31, 2017
 Engineer's Name PE# Date

Engineer's Signature

SECTION
WASTEWATER

DETAIL NO.
 WW-15

TITLE
 DROP CONNECTION
 MANHOLE - TYPE 'A'

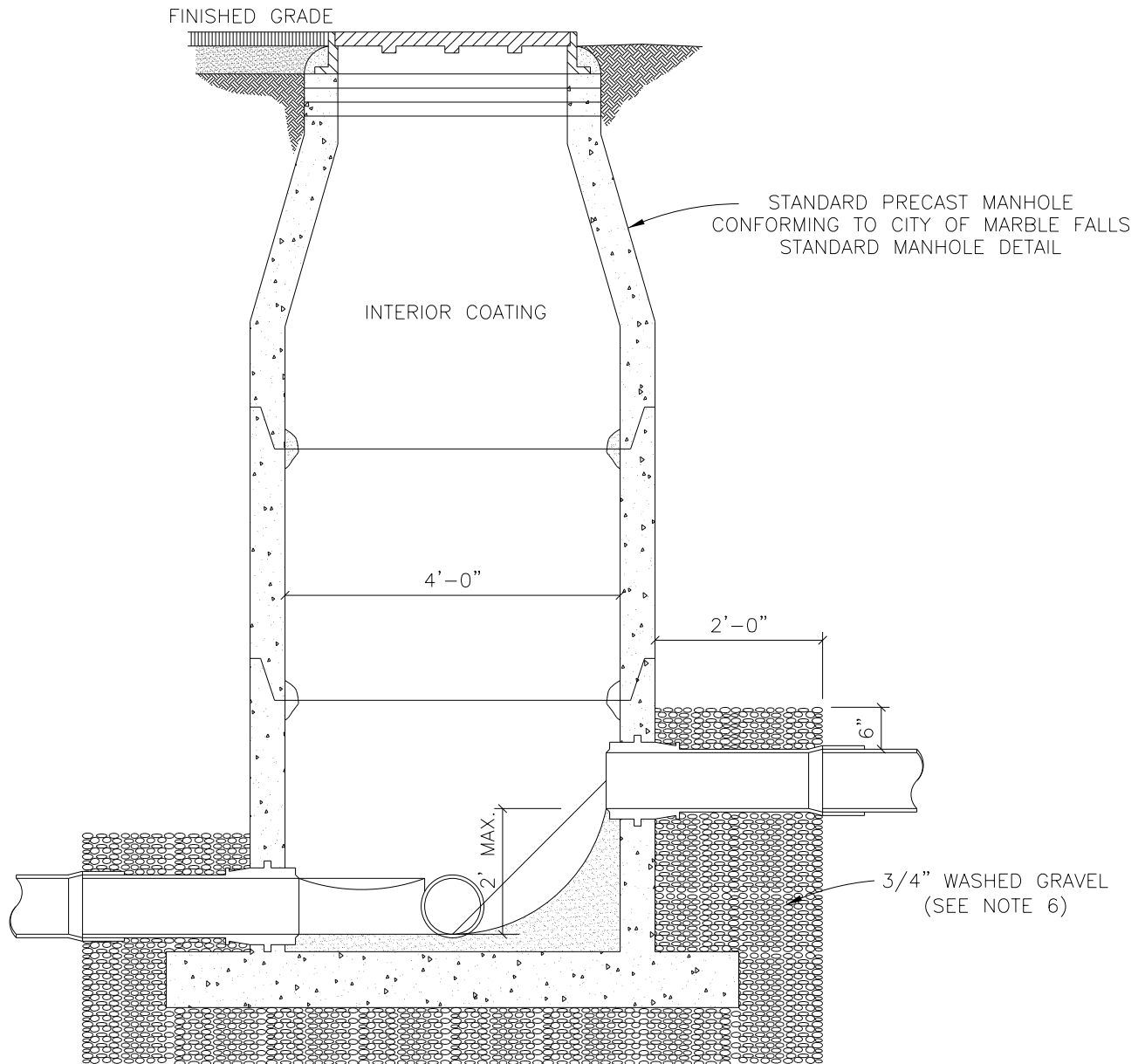

NOTES:

1. TO BE USED WHERE DROP IS SIX INCHES (6") TO TWO FEET (2'-0").
2. A FLOW CHANNEL SHALL BE CONSTRUCTED INSIDE MANHOLE TO DIRECT INFLUENT INTO FLOW STREAM.
3. MINIMUM PIPE SIZE FOR DROP IS EIGHT INCHES (8").
4. SEE STANDARD DETAIL (STANDARD MANHOLE SECTION) FOR ADDITIONAL REQUIREMENTS.

SCALE: NOT TO SCALE



MARBLE FALLS
800 THIRD STREET
MARBLE FALLS, TX 78654
PH: (830) 693-6737

These documents were prepared by,
or under the supervision of:

ERIC BELAJ 107148 May 31, 2017
Engineer's Name PE# Date

Eric Belaj
Engineer's Signature

SECTION
WASTEWATER

DETAIL NO.
WW-16

TITLE
DROP CONNECTION
MANHOLE - TYPE 'B'

CONCRETE COLLAR
(MIN. 3,000 PSI) WITH 6X6 -
W1.4 X W1.4 WELDED WIRE
FABRIC OVER BACKFILL

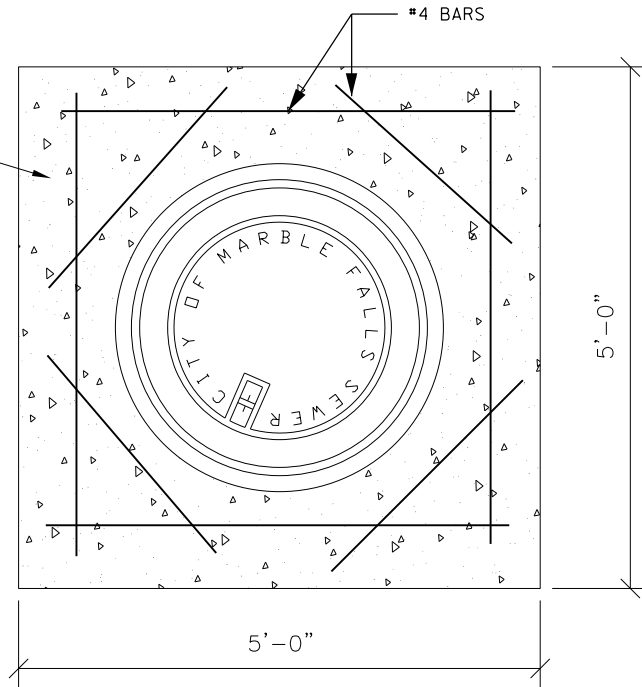

PLAN

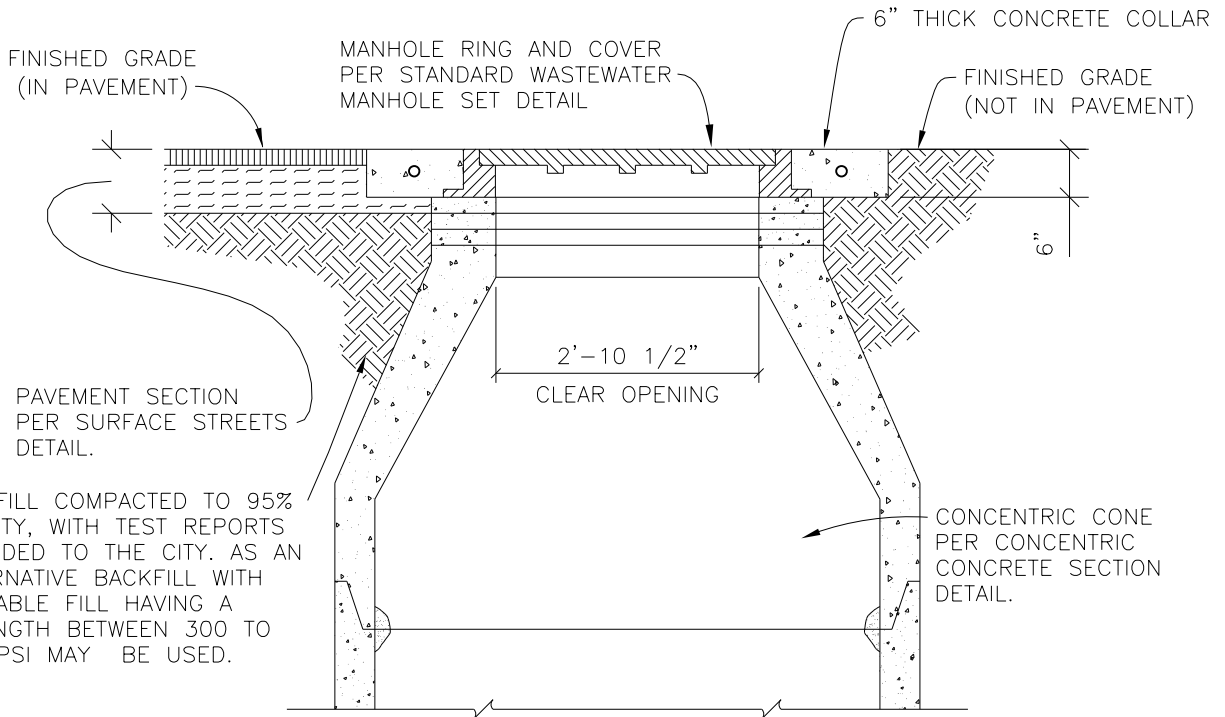

SECTION

SCALE: NOT TO SCALE



MARBLE FALLS
800 THIRD STREET
MARBLE FALLS, TX 78654
PH: (830) 693-6737

These documents were prepared by,
or under the supervision of:

ERIC BELAJ 107148 May 31, 2017
Engineer's Name PE# Date



Engineer's Signature

SECTION
WASTEWATER

DETAIL NO.
WW-17

TITLE
MANHOLE CONCRETE
APRON

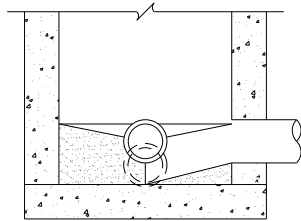
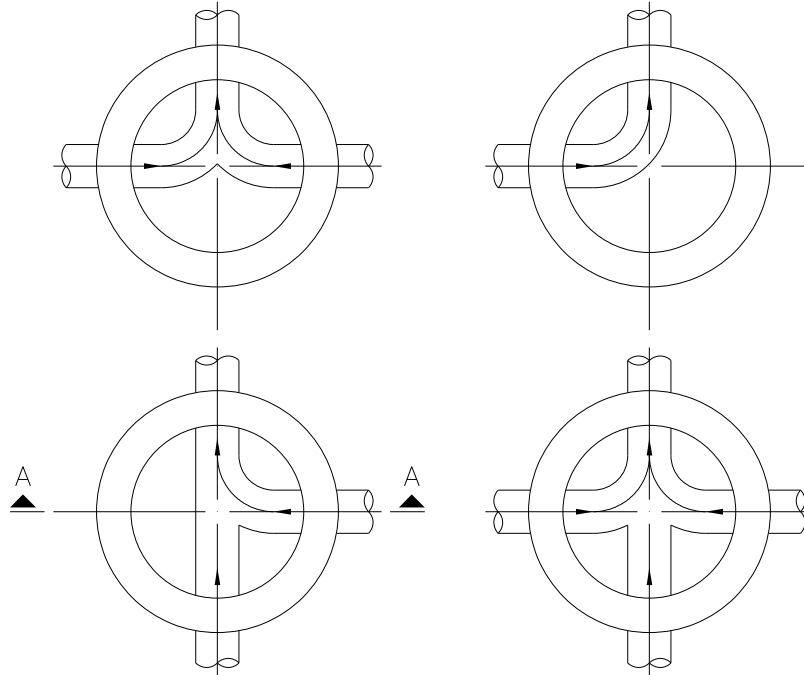
FLOW PATTERNS FOR INVERT CHANNELS



SECTION "A-A"

NOTES:

1. INVERT CHANNELS TO BE CONSTRUCTED FOR SMOOTH FLOW WITH NO OBSTRUCTIONS.
2. SPILLWAYS SHALL BE CONSTRUCTED BETWEEN PIPES WITH DIFFERENT INVERT ELEVATIONS PROVIDING FOR SMOOTH FLOW.
3. CHANNELS FOR FUTURE CONSTRUCTIONS (STUBS) SHALL BE CONSTRUCTED, FILLED WITH SAND, AND COVERED WITH 1" OF MORTAR.
4. SLOPE MANHOLE ITSELF WITH A 1:2 SLOPE FROM MANHOLE WALL TO CHANNEL.
5. INVERT SHALL BE A MINIMUM OF 1/2 THE DIAMETER OF THE LARGEST PIPE OR 4" DEEP.

SCALE: NOT TO SCALE



MARBLE FALLS
800 THIRD STREET
MARBLE FALLS, TX 78654
PH: (830) 693-6737

These documents were prepared by,
or under the supervision of:

ERIC BELAJ 107148 May 31, 2017
Engineer's Name PE# Date

Engineer's Signature

SECTION

WASTEWATER

DETAIL NO.

WW-18

TITLE

INVERT FLOW PATTERNS

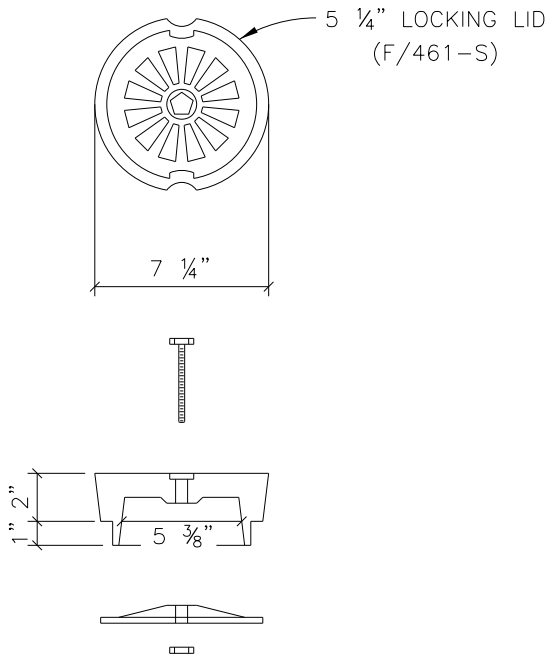

5 1/4" LOCKING LID
(F/461-S)

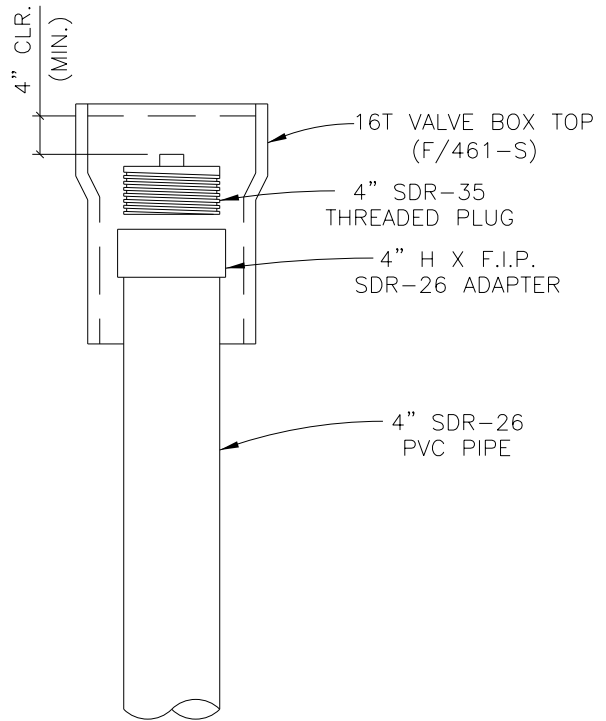

SEWER CLEAN-OUT
CITY OF MARBLE FALLS
(RESIDENTIAL SERVICE)

SCALE: NOT TO SCALE



MARBLE FALLS
800 THIRD STREET
MARBLE FALLS, TX 78654
PH: (830) 693-6737

These documents were prepared by,
or under the supervision of:

ERIC BELAJ 107148 May 31, 2017
Engineer's Name PE# Date

Engineer's Signature

SECTION
WASTEWATER

DETAIL NO.
WW-19

TITLE
CLEAN - OUT



SEWER VALVE LID

"WATER" TO BE CAST IN COVER WHEN USED ON WATER MAIN OR "SEWER" WHEN USED ON FORCE MAIN

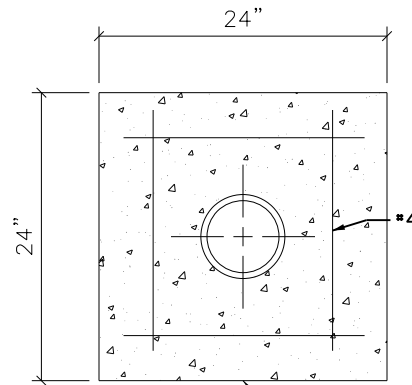

CONCRETE COLLAR
6" THICK MINIMUM

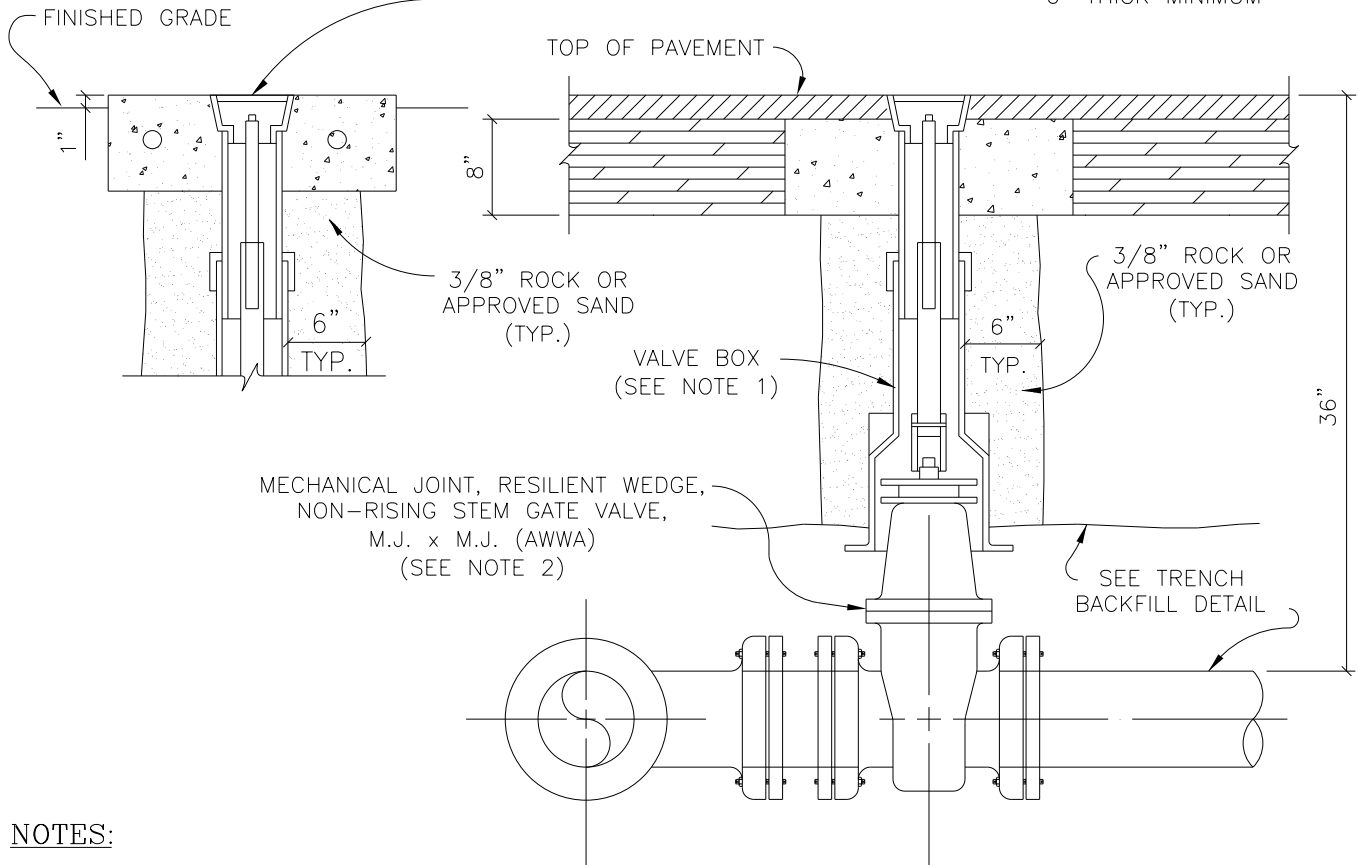

NOTES:

1. VALVE BOX SHALL BE AMERICAN FLOW CONTROL TRENCH ADAPTER OR APPROVED EQUAL HAVING AN ADJUSTABLE RANGE OF + OR - 6 INCHES FROM INSTALLED FINISH GRADE.
2. ACCEPTABLE GATE VALVES ARE:
 - A. AMERICAN FLOW CONTROL - SERIES 2550
 - B. MUELLER - 2360 SERIES
 - C. CLOW

SCALE: NOT TO SCALE



MARBLE FALLS
800 THIRD STREET
MARBLE FALLS, TX 78654
PH: (830) 693-6737

These documents were prepared by,
or under the supervision of:

ERIC BELAJ 107148 May 31, 2017
Engineer's Name PE# Date

[Handwritten Signature]
Engineer's Signature

SECTION
WASTEWATER

DETAIL NO.
WW-20

TITLE
WASTEWATER VALVE



SEWER VALVE LID

"WATER" TO BE CAST IN COVER WHEN USED ON WATER MAIN OR "SEWER" WHEN USED ON FORCE MAIN

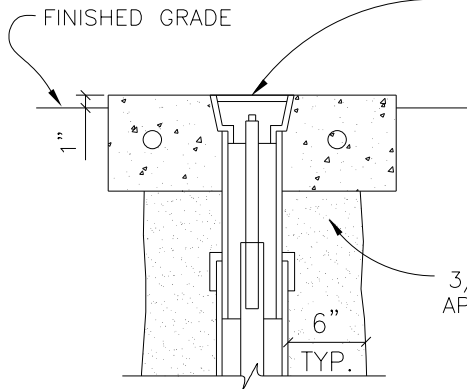

"SEWER" TO BE CAST IN COVER WHEN USED ON FORCE MAIN

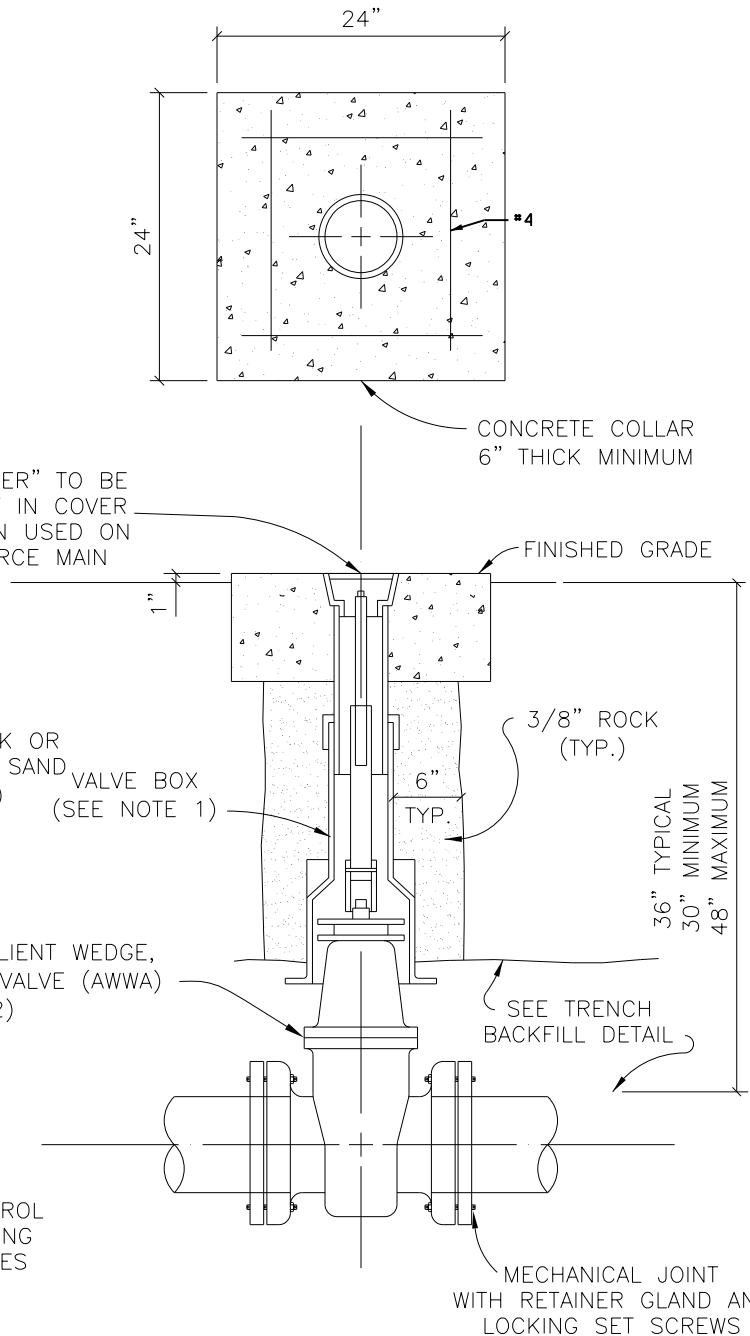

MECHANICAL JOINT, RESILIENT WEDGE, NON-RISING STEM GATE VALVE (AWWA) (SEE NOTE 2)

MECHANICAL JOINT WITH RETAINER GLAND AND LOCKING SET SCREWS

36" TYPICAL
30" MINIMUM
48" MAXIMUM

NOTES:

1. VALVE BOX SHALL BE AMERICAN FLOW CONTROL TRENCH ADAPTER OR APPROVED EQUAL HAVING AN ADJUSTABLE RANGE OF + OR - 6 INCHES FROM INSTALLED FINISH GRADE. (SEE TYPICAL SEWER VALVE SETTING)
2. ACCEPTABLE GATE VALVES ARE:
 - A. AMERICAN FLOW CONTROL - SERIES 2500
 - B. MUELLER - 2360 SERIES
 - C. CLOW

SCALE: NOT TO SCALE



MARBLE FALLS
800 THIRD STREET
MARBLE FALLS, TX 78654
PH: (830) 693-6737

These documents were prepared by,
or under the supervision of:

ERIC BELAJ 107148 May 31, 2017
Engineer's Name PE# Date

[Signature]
Engineer's Signature

SECTION
WASTEWATER

DETAIL NO.
WW-21

TITLE
IN-LINE VALVE

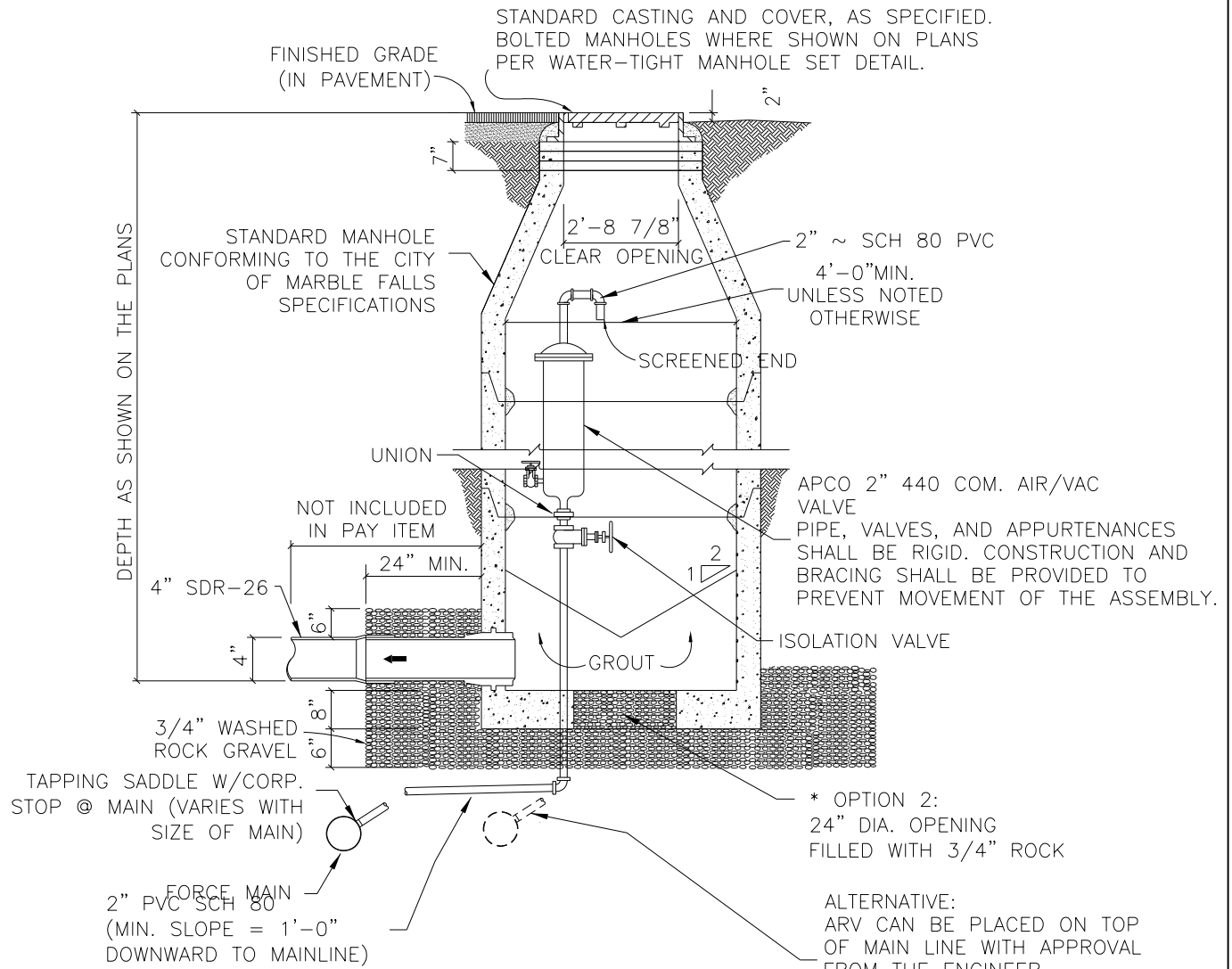

*WHERE AIR RELEASE/VACUUM VALVE CANNOT BE TIED BACK INTO A WASTEWATER MANHOLE USE OPTION 2.

LIMITS OF PAY FOR THIS ITEM INCLUDES THE FOLLOWING:

1. INSTALLING THE TAPPING SADDLE AND CORP. STOP ONTO THE MAIN.
2. INSTALLING THE 2" PVC SCH. 80 FROM MAIN TO MANHOLE LOCATION.
3. INSTALLING THE MANHOLE (SEE STANDARD MANHOLE DETAIL).
4. INSTALLING THE AIR/VAC VALVE.

SCALE: NOT TO SCALE



MARBLE FALLS
800 THIRD STREET
MARBLE FALLS, TX 78654
PH: (830) 693-6737

These documents were prepared by,
or under the supervision of:

ERIC BELAJ 107148 May 31, 2017
Engineer's Name PE# Date

Engineer's Signature

SECTION
WASTEWATER

DETAIL NO.
WW-22

TITLE
AIR RELEASE
VACUUM VALVE

NOTE:

ROTATE RISER AS NEEDED TO PROVIDE ACCESS TO COUPLING AND REDUCE POTENTIAL EROSION

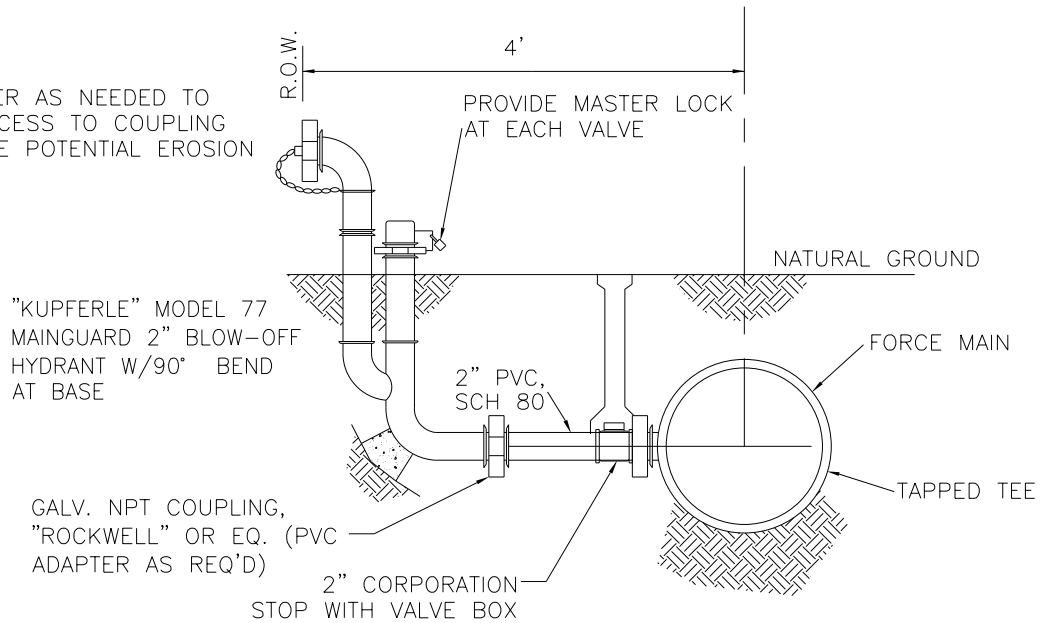

NOTE:

THRUST BLOCKING SHALL BE PLACED IN A MANNER SO AS NOT TO PLUG OR BLOCK INTEGRAL WEEP HOLE FLUSH VALVES SHALL BE KUPFERLE MODEL 77 (OR EQUAL)

SCALE: NOT TO SCALE



MARBLE FALLS
800 THIRD STREET
MARBLE FALLS, TX 78654
PH: (830) 693-6737

These documents were prepared by,
or under the supervision of:

ERIC BELAJ 107148 May 31, 2017
Engineer's Name PE# Date

Engineer's Signature

SECTION
WASTEWATER

DETAIL NO.
WW-23

TITLE
FLUSH CONNECTION

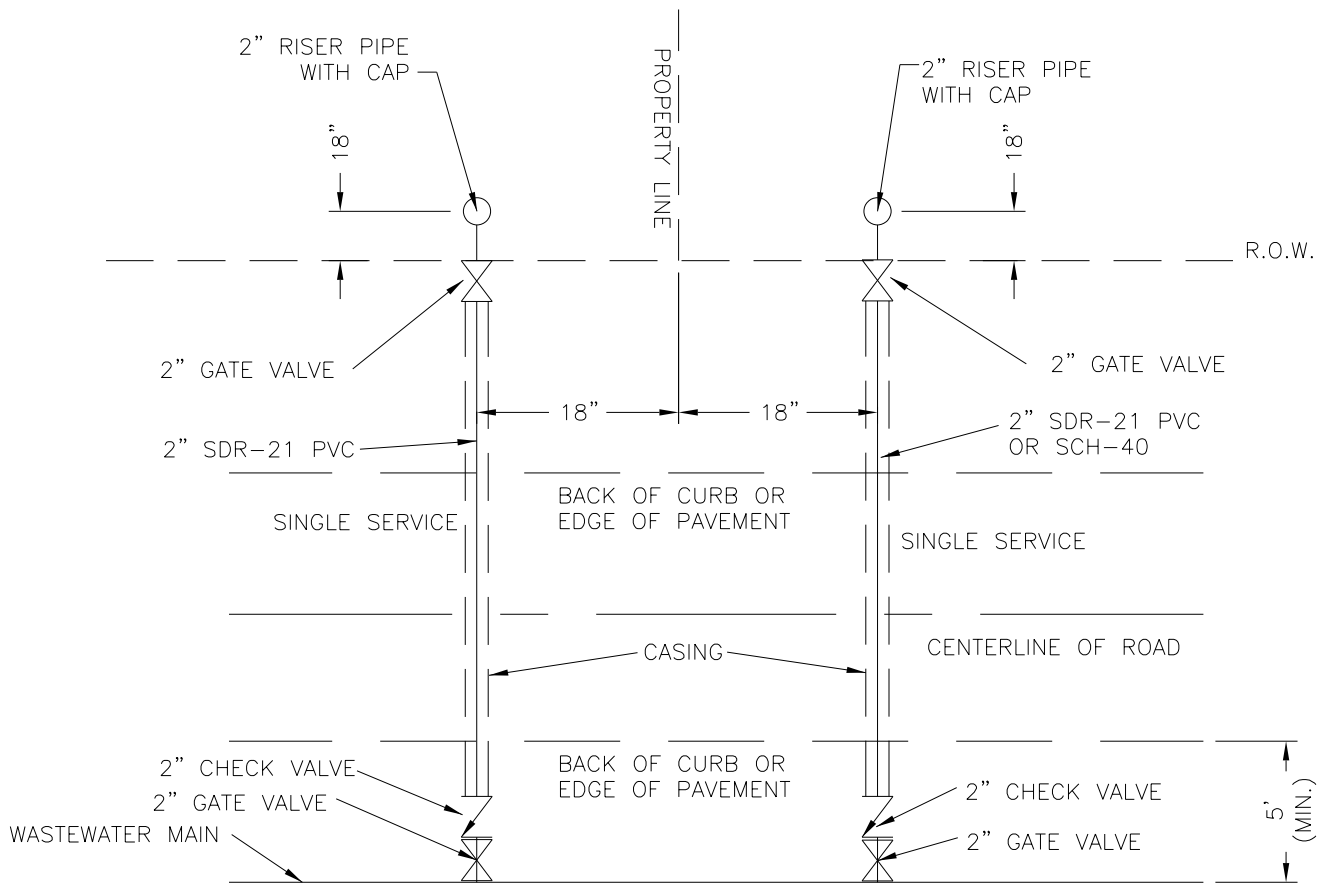

SERVICE NOTES:

1. PROPOSED GRINDER PUMP SYSTEM MANUFACTURER & MODEL, AS WELL AS SUPPORTING PUMP SIZING CRITERIA, SHALL BE SUBMITTED TO THE CITY OF MARBLE FALLS FOR APPROVAL PRIOR TO INSTALLATION.
2. SEWER FORCE MAIN WILL REQUIRE FLUSHING A MINIMUM OF ONCE EVERY TWO (2) WEEKS, OR AS DETERMINED BY THE CITY OF MARBLE FALLS.

SCALE: NOT TO SCALE



MARBLE FALLS
800 THIRD STREET
MARBLE FALLS, TX 78654
PH: (830) 693-6737

These documents were prepared by,
or under the supervision of:

ERIC BELAJ 107148 May 31, 2017
Engineer's Name PE# Date

Engineer's Signature

SECTION

WASTEWATER

DETAIL NO.

WW-24

TITLE

LONG RESIDENTIAL FM
SERVICE LINE PLAN

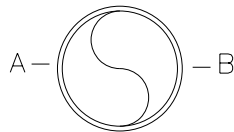
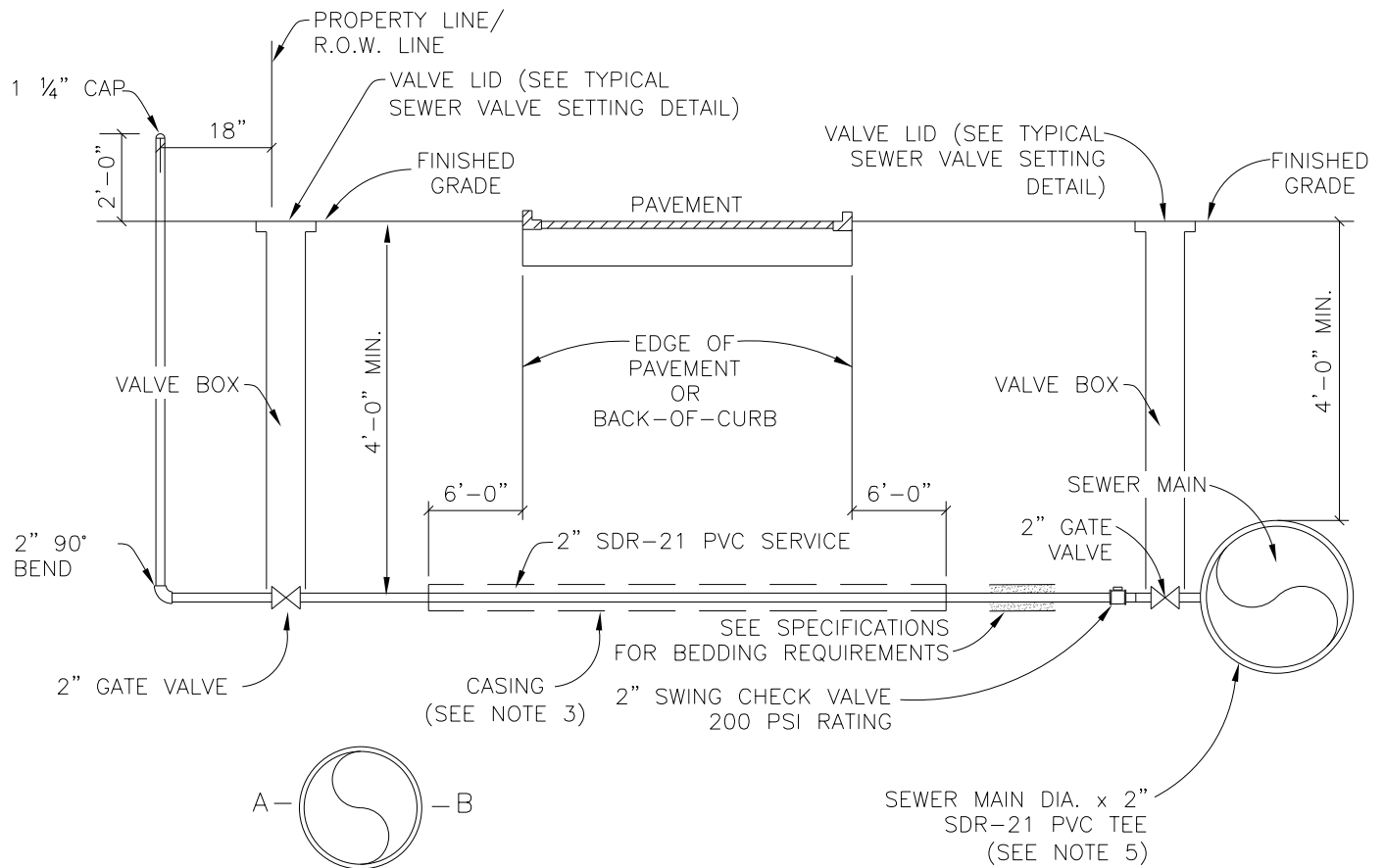

DETAIL "A"

NOTES:

1. SUCCESSIVE TEES INTO THE SEWER MAIN SHALL BE SPACED A MINIMUM OF 18" OFFSET AND AT THE CENTERLINE AS SHOWN ON DETAIL "A".
2. THE TOP OF RISER PIPE SHALL BE SET 2' ABOVE FINISHED GRADE.
3. CASING REQUIRED FOR ALL PAVEMENT CROSSINGS. 4" SDR-26 OR SCH-40 REQUIRED FOR OPEN-CUT. STEEL CASING PIPE REQUIRED FOR JACK AND BORE. LIMITS OF CASING SHOULD EXTEND SIX FEET BEYOND THE EDGE OF PAVEMENT OR BACK-OF-CURB.
4. ANY VARIATIONS ON FITTINGS MUST BE APPROVED BY THE MARBLE FALLS PUBLIC WORKS DEPARTMENT.
5. WET CONNECTIONS TO ACTIVE WASTEWATER FORCE MAINS SHALL BE REQUIRED. SMITH-BLAIR 372 ALL STAINLESS STEEL, DOUBLE STUD SERVICE SADDLES SHALL BE REQUIRED FOR SINGLE FAMILY RESIDENTIAL WET TAPS TO FORCE MAINS.

SCALE: NOT TO SCALE



MARBLE FALLS
 800 THIRD STREET
 MARBLE FALLS, TX 78654
 PH: (830) 693-6737

These documents were prepared by,
 or under the supervision of:

ERIC BELAJ 107148 May 31, 2017
 Engineer's Name PE# Date

 Engineer's Signature

SECTION
WASTEWATER

DETAIL NO.
WW-25

TITLE
 LONG RESIDENTIAL FM
 SERVICE LINE SECTION

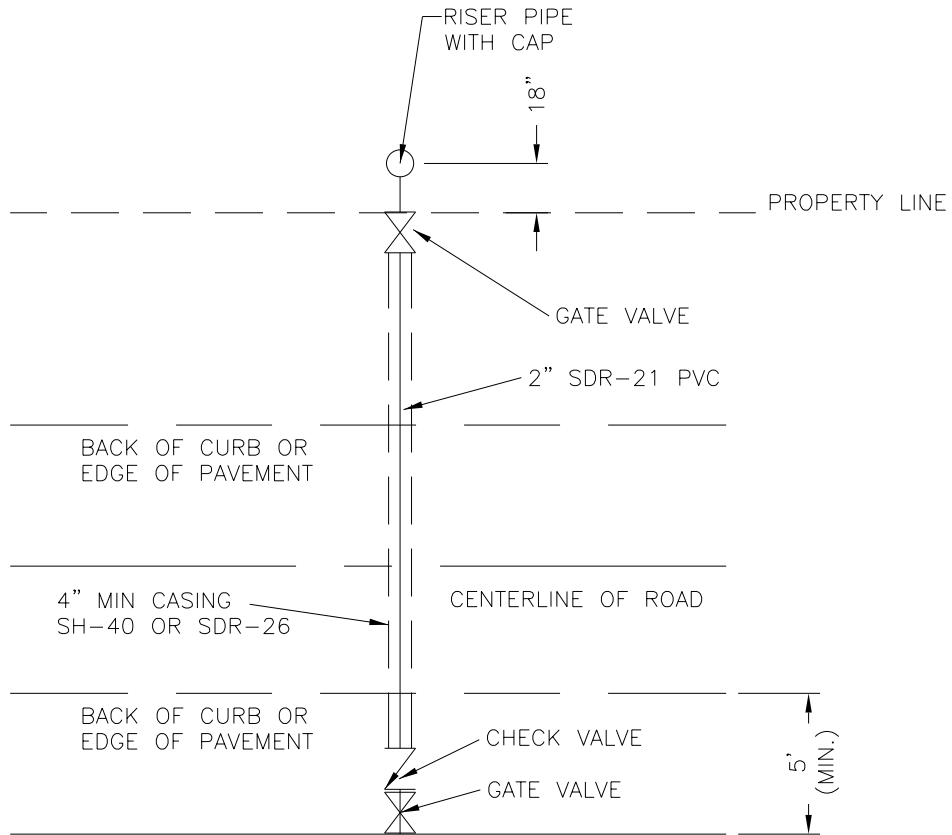

SERVICE NOTES:

1. PROPOSED GRINDER PUMP SYSTEM MANUFACTURER & MODEL, AS WELL AS SUPPORTING PUMP SIZING CRITERIA, SHALL BE SUBMITTED TO THE CITY OF MARBLE FALLS FOR APPROVAL PRIOR TO INSTALLATION.
2. SEWER FORCE MAIN WILL REQUIRE FLUSHING A MINIMUM OF ONCE EVERY TWO (2) WEEKS, OR AS DETERMINED BY THE CITY OF MARBLE FALLS.
3. SIZE OF SERVICE PIPE AND VALVES SHALL BE CONSTANT THROUGHOUT THE SERVICE LEAD.
4. SIZE OF SERVICE LEAD SHALL BE AS CALLED OUT IN THE CONTRACT DOCUMENTS.

SCALE: NOT TO SCALE



MARBLE FALLS
 800 THIRD STREET
 MARBLE FALLS, TX 78654
 PH: (830) 693-6737

These documents were prepared by,
 or under the supervision of:

ERIC BELAJ 107148 May 31, 2017
 Engineer's Name PE# Date

Engineer's Signature

SECTION
WASTEWATER

DETAIL NO.
WW-26

TITLE
 LONG NON-RESIDENTIAL FM
 SERVICE LINE PLAN

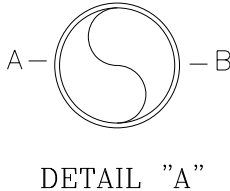
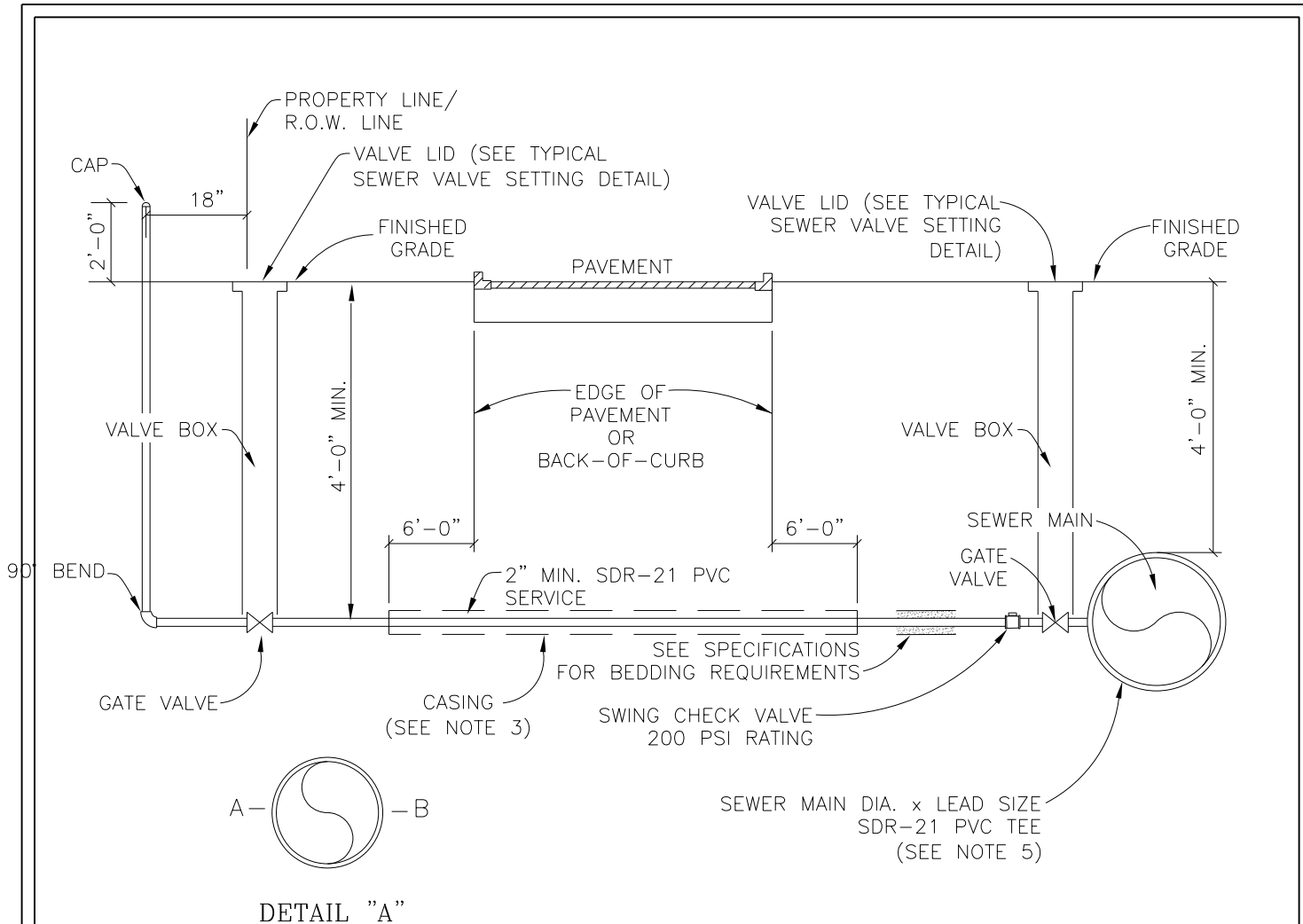

NOTES:

1. SUCCESSIVE TEES INTO THE SEWER MAIN SHALL BE SPACED A MINIMUM OF 18" OFFSET AND AT THE CENTERLINE AS SHOWN ON DETAIL "A".
2. THE TOP OF RISER PIPE SHALL BE SET 2' ABOVE FINISHED GRADE.
3. SDR-26 OR SCH-40 CASING REQUIRED FOR ALL PAVEMENT CROSSINGS. CASING SHALL BE AT LEAST TWICE THE DIAMETER OF THE SERVICE. STEEL CASING PIPE REQUIRED FOR JACK AND BORE. LIMITS OF CASING SHOULD EXTEND SIX FEET BEYOND THE EDGE OF PAVEMENT OR BACK-OF-CURB.
4. ANY VARIATIONS ON FITTINGS MUST BE APPROVED BY THE MARBLE FALLS PUBLIC WORKS DEPARTMENT.
5. WET CONNECTIONS TO ACTIVE WASTEWATER FORCE MAINS SHALL BE REQUIRED. SERVICE LEADS 2" IN DIAMETER SHALL USE SMITH-BLAIR 372 ALL STAINLESS STEEL, DOUBLE STUD SERVICE SADDLES FOR WET TAPS TO FORCE MAINS. SERVICE LEADS LARGER THAN 2" IN DIAMETER SHALL REQUIRE SMITH-BLAIR 663 ALL STAINLESS STEEL TAPPING SLEEVES FOR WET CONNECTIONS TO FORCE MAINS.

SCALE: NOT TO SCALE



MARBLE FALLS
 800 THIRD STREET
 MARBLE FALLS, TX 78654
 PH: (830) 693-6737

These documents were prepared by,
 or under the supervision of:

ERIC BELAJ 107148 May 31, 2017
 Engineer's Name PE# Date



Engineer's Signature

SECTION
WASTEWATER

DETAIL NO.
WW-27

TITLE
 LONG NON-RESIDENTIAL FM
 SERVICE LINE SECTION

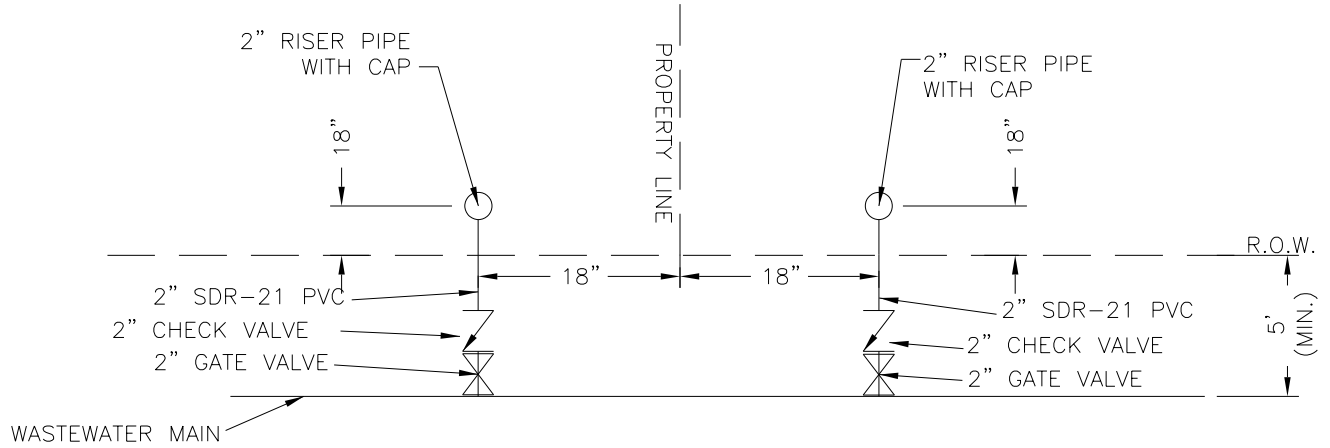

SERVICE NOTES:

1. PROPOSED GRINDER PUMP SYSTEM MANUFACTURER & MODEL, AS WELL AS SUPPORTING PUMP SIZING CRITERIA, SHALL BE SUBMITTED TO THE CITY OF MARBLE FALLS FOR APPROVAL PRIOR TO INSTALLATION.
2. SEWER FORCE MAIN WILL REQUIRE FLUSHING A MINIMUM OF ONCE EVERY TWO (2) WEEKS, OR AS DETERMINED BY THE CITY OF MARBLE FALLS.

SCALE: NOT TO SCALE



MARBLE FALLS
 800 THIRD STREET
 MARBLE FALLS, TX 78654
 PH: (830) 693-6737

These documents were prepared by,
 or under the supervision of:

ERIC BELAJ 107148 May 31, 2017
 Engineer's Name PE# Date

Engineer's Signature

SECTION
WASTEWATER

DETAIL NO.
 WW-28

TITLE
 SHORT RESIDENTIAL FM
 SERVICE LINE PLAN

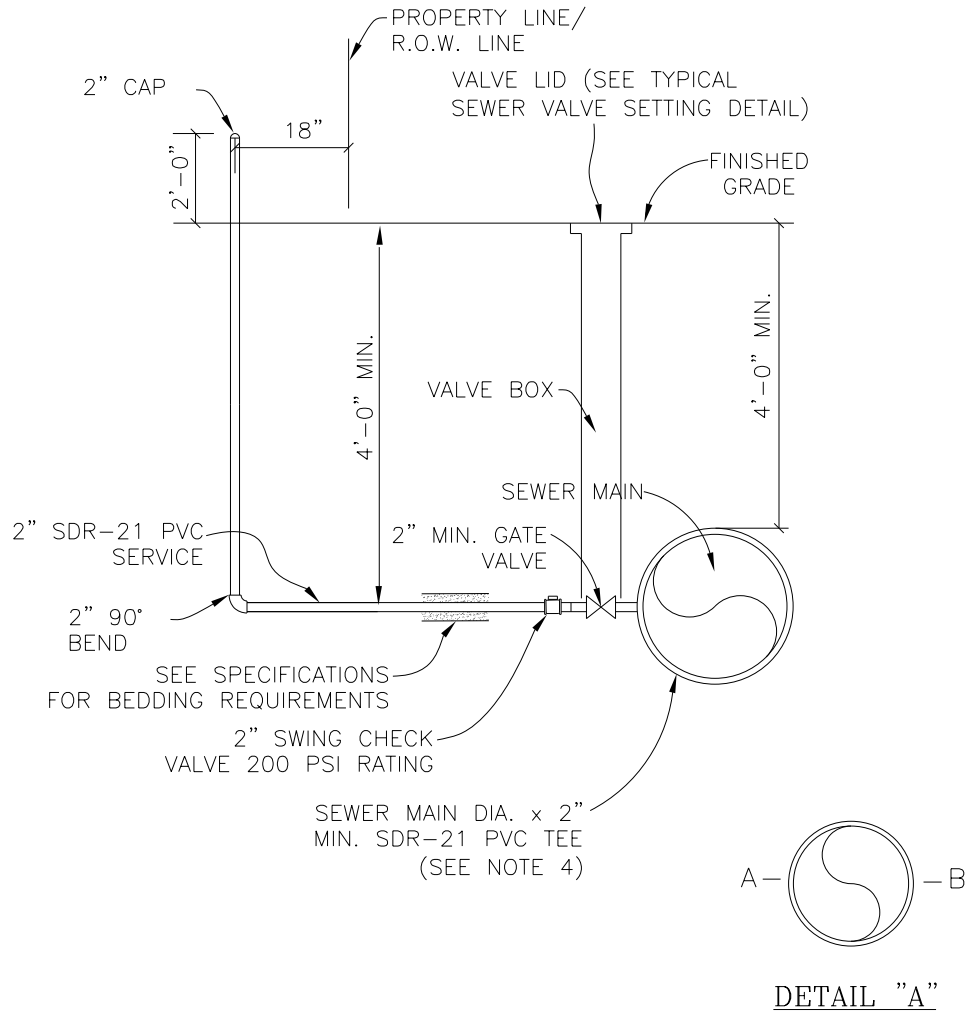

NOTES:

1. SUCCESSIVE TEES INTO THE SEWER MAIN SHALL BE SPACED A MINIMUM OF 18" OFFSET AND AT THE CENTERLINE AS SHOWN ON DETAIL "A".
2. THE TOP OF RISER PIPE SHALL BE SET 2' ABOVE FINISHED GRADE.
3. ANY VARIATIONS ON FITTINGS MUST BE APPROVED BY THE MARBLE FALLS PUBLIC WORKS DEPARTMENT.
4. WET CONNECTIONS TO ACTIVE WASTEWATER FORCE MAINS SHALL BE REQUIRED. SMITH-BLAIR 372 ALL STAINLESS STEEL, DOUBLE STUD SERVICE SADDLES SHALL BE REQUIRED FOR SINGLE FAMILY RESIDENTIAL WET TAPS TO FORCE MAINS.

SCALE: NOT TO SCALE



MARBLE FALLS
800 THIRD STREET
MARBLE FALLS, TX 78654
PH: (830) 693-6737

These documents were prepared by,
or under the supervision of:

ERIC BELAJ 107148 May 31, 2017
Engineer's Name PE# Date

[Signature]
Engineer's Signature

SECTION
WASTEWATER

DETAIL NO.
WW-29

TITLE
SHORT RESIDENTIAL FM
SERVICE LINE SECTION

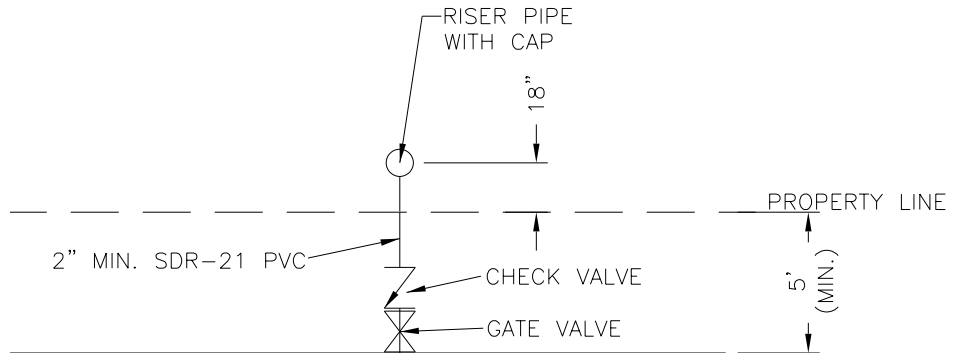

SERVICE NOTES:

1. PROPOSED GRINDER PUMP SYSTEM MANUFACTURER & MODEL, AS WELL AS SUPPORTING PUMP SIZING CRITERIA, SHALL BE SUBMITTED TO THE CITY OF MARBLE FALLS FOR APPROVAL PRIOR TO INSTALLATION.
2. SEWER FORCE MAIN WILL REQUIRE FLUSHING A MINIMUM OF ONCE EVERY TWO (2) WEEKS, OR AS DETERMINED BY THE CITY OF MARBLE FALLS.
3. SIZE OF SERVICE PIPE AND VALVES SHALL BE CONSTANT THROUGHOUT THE SERVICE LEAD.
4. SIZE OF SERVICE LEAD SHALL BE AS CALLED OUT IN THE CONTRACT DOCUMENTS.

SCALE: NOT TO SCALE



MARBLE FALLS
 800 THIRD STREET
 MARBLE FALLS, TX 78654
 PH: (830) 693-6737

These documents were prepared by,
 or under the supervision of:

ERIC BELAJ 107148 May 31, 2017
 Engineer's Name PE# Date

Engineer's Signature

SECTION

WASTEWATER

DETAIL NO.

WW-30

TITLE

SHORT NON-RESIDENTIAL FM
 SERVICE LINE PLAN

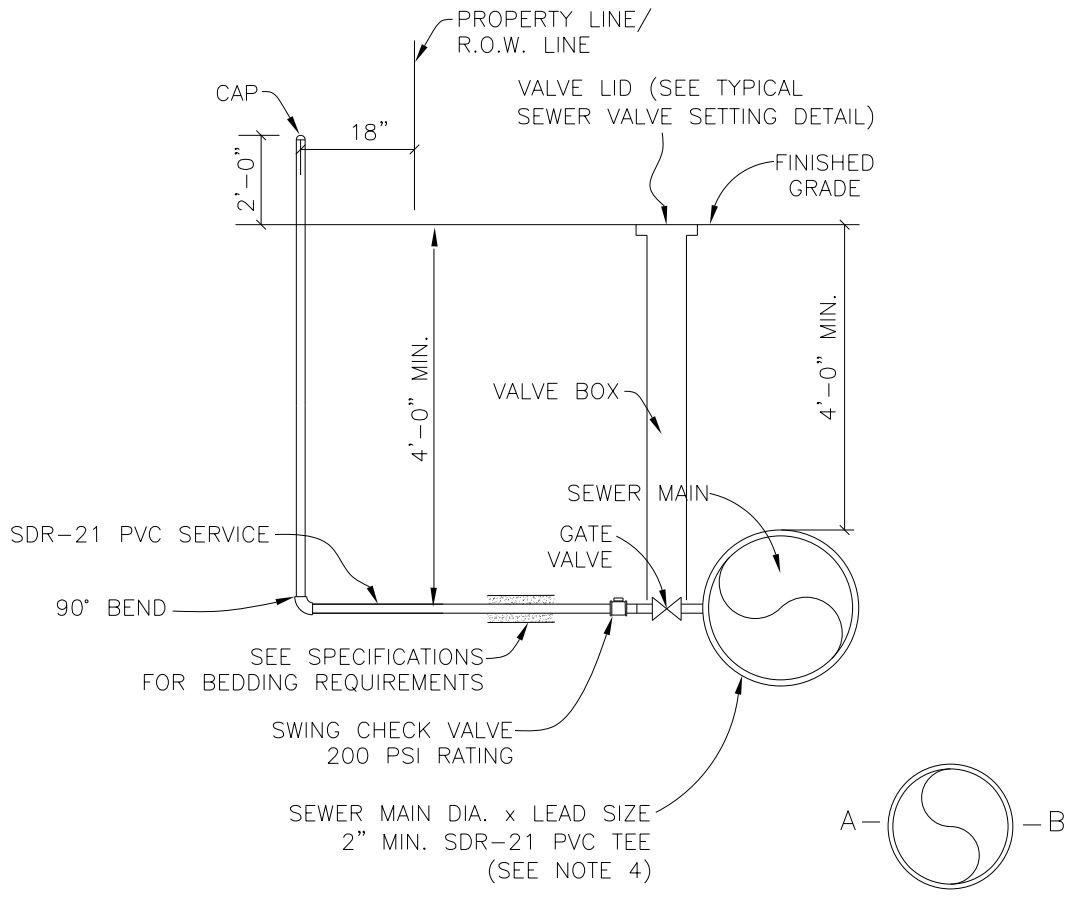

DETAIL "A"

NOTES:

1. SUCCESSIVE TEES INTO THE SEWER MAIN SHALL BE SPACED A MINIMUM OF 18" OFFSET AND AT THE CENTERLINE AS SHOWN ON DETAIL "A".
2. THE TOP OF RISER PIPE SHALL BE SET 2' ABOVE FINISHED GRADE.
3. ANY VARIATIONS ON FITTINGS MUST BE APPROVED BY THE MARBLE FALLS PUBLIC WORKS DEPARTMENT.
4. WET CONNECTIONS TO ACTIVE WASTEWATER FORCE MAINS SHALL BE REQUIRED. SERVICE LEADS 2" IN DIAMETER SHALL USE SMITH-BLAIR 372 ALL STAINLESS STEEL, DOUBLE STUD SERVICE SADDLES FOR WET TAPS TO FORCE MAINS. SERVICE LEADS LARGER THAN 2" IN DIAMETER SHALL REQUIRE SMITH-BLAIR 663 ALL STAINLESS STEEL TAPPING SLEEVES FOR WET CONNECTIONS TO FORCE MAINS.

SCALE: NOT TO SCALE



MARBLE FALLS
 800 THIRD STREET
 MARBLE FALLS, TX 78654
 PH: (830) 693-6737

These documents were prepared by,
 or under the supervision of:

ERIC BELAJ 107148 May 31, 2017
 Engineer's Name PE# Date

[Signature]
 Engineer's Signature

SECTION	WASTEWATER
DETAIL NO.	WW-31
TITLE	SHORT NON-RESIDENTIAL FM SERVICE LINE SECTION

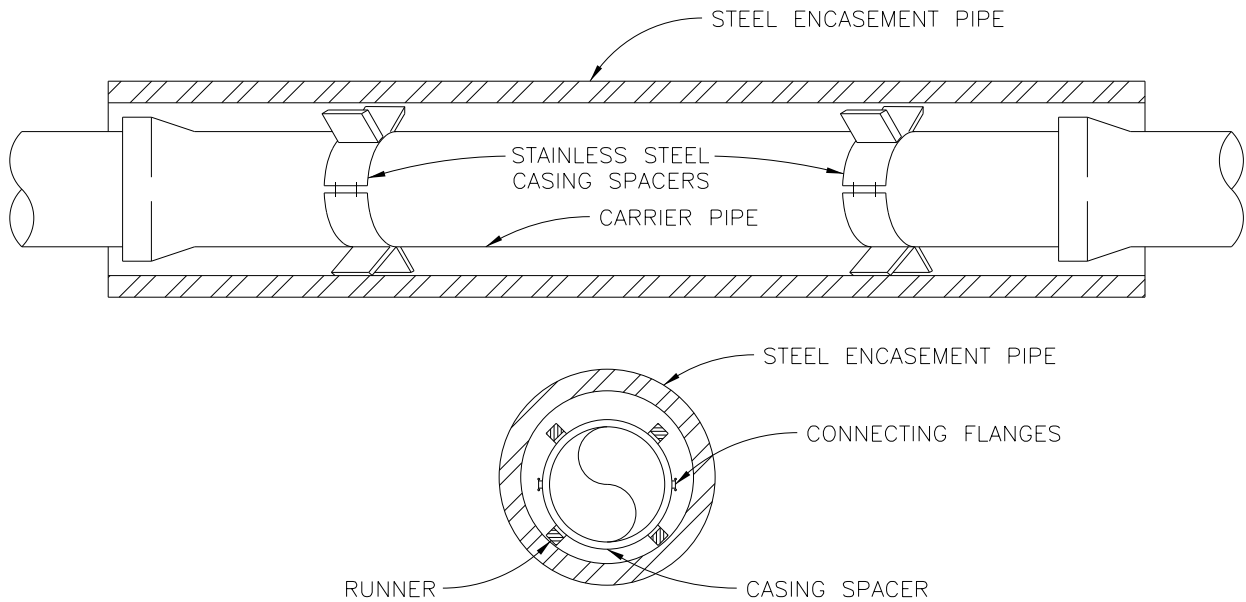

NOTES:

1. CASING SPACERS SHALL BE BOLT ON STYLE WITH A SHELL MADE IN TWO SECTIONS OF HEAVY T-304 STAINLESS STEEL. CONNECTING FLANGES SHALL BE RIBBED FOR EXTRA STRENGTH. SEE SPECIFICATIONS FOR APPROVED CASING SPACERS.
2. CASING SPACERS SHALL HAVE RUNNERS MADE OF ULTRA HIGH MOLECULAR WEIGHT POLYMER, WITH A MINIMUM HEIGHT OF 2 INCHES.
3. DO NOT USE WEDGES BETWEEN TOP OF CARRIER PIPE AND INSIDE OF CASING TO KEEP PIPE FROM MOVING.
4. PRIOR TO INSERTING CARRIER PIPE, ANY WATER SHOULD BE PUMPED OUT OF THE CASING PIPE SO THAT NO MORE THAN A FEW INCHES OF WATER REMAINS.
5. SPACERS WILL BE REQUIRED WITHIN AT LEAST 3 FEET FROM BOTH OPENINGS OF THE ENCASEMENT PIPE AND SPACED NO GREATER THAN 6 FEET THROUGHOUT THE ENCASEMENT PIPE. IN ADDITION, SPACERS SHALL BE REQUIRED WITHIN 2 FEET OF ALL PIPE JOINTS.
6. ENCASEMENT PIPE SHALL BE SMOOTH STEEL 35,000 PSI YIELD STRENGTH WITH THICKNESS ACCORDING TO THE FOLLOWING TABLE:

PIPE SIZE-CARRIER (DIAMETER)	PIPE SIZE-CASING (DIAMETER)(MIN.)	MINIMUM PIPE THICKNESS (INCHES)	
		1/4	0.2500
6"	16"	1/4	0.2500
8"	18"	5/16	0.3125
10"	20"	3/8	0.3750
12" - 14"	24"	7/16	0.4375
16" - 18"	30"	1/2	0.5000
20"	36"	1/2	0.5000
24"	42"	1/2	0.5000
30"	48"	1/2	0.5000

SCALE: NOT TO SCALE



MARBLE FALLS
800 THIRD STREET
MARBLE FALLS, TX 78654
PH: (830) 693-6737

These documents were prepared by,
or under the supervision of:

ERIC BELAJ 107148 May 31, 2017
Engineer's Name PE# Date

(Handwritten Signature)
Engineer's Signature

SECTION
WASTEWATER

DETAIL NO.
WW-32

TITLE
PIPE CASING

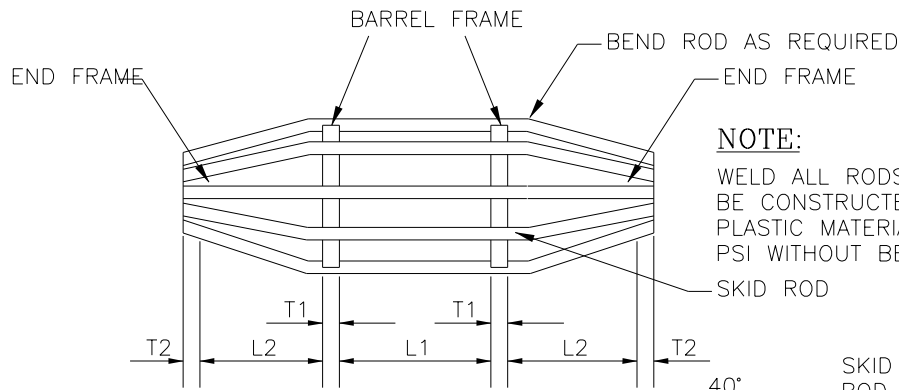

NOTE:

WELD ALL RODS TO FRAME. MANDREL SHALL BE CONSTRUCTED FROM METAL OR RIGID PLASTIC MATERIAL THAT CAN WITHSTAND 200 PSI WITHOUT BEING DEFORMED.

1/4" EYE BOLT W/
NUTS LENGTH AS
REQUIRED

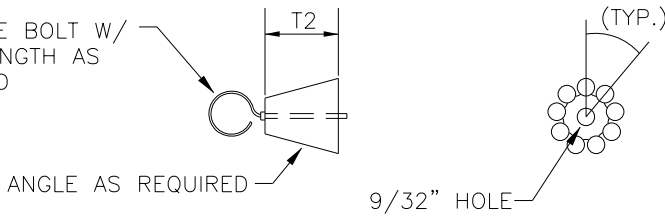

TYPICAL BOTH ENDS
END FRAME

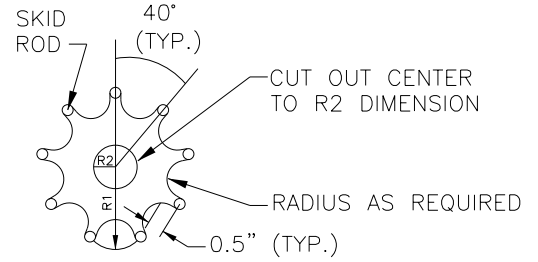

BARREL FRAME

MANDREL DIMENSIONS - 5% DEFLECTION
FOR O.D. CONTROLLED PVC PIPE*

SIZE	TYPE	O.D. AVERAGE	MIN. WALL THICKNESS	L1	L2	R1	R2	T1	T2	ROD DIAMETER
6"	D3034 SDR35	6.275	0.180	4.50	6	2.81	0.75	0.375	1.0	0.375
8"	D3034 SDR35	8.400	0.240	6.00	6	3.76	1.25	0.375	1.0	0.375
10"	D3034 SDR35	10.500	0.300	7.50	6	4.70	1.50	0.375	1.0	0.375
12"	D3034 SDR35	12.500	0.360	9.00	6	5.60	1.75	0.375	1.0	0.375
15"	D3034 SDR35	15.300	0.437	1.25	6	6.85	2.00	0.375	1.0	0.375
18"	F679 T-1	18.701	0.536	13.50	9	8.37	2.50	0.50	1.5	0.50
21"	F679 T-1	22.047	0.632	15.75	9	9.87	3.00	0.50	1.5	0.50
24"	F679 T-1	24.803	0.711	18.00	9	11.11	3.50	0.50	1.5	0.50
27"	F679 T-1	27.953	0.801	20.25	9	12.52	4.00	0.50	1.5	0.50

* ALL DIMENSIONS IN INCHES

SCALE: NOT TO SCALE



MARBLE FALLS
800 THIRD STREET
MARBLE FALLS, TX 78654
PH: (830) 693-6737

These documents were prepared by,
or under the supervision of:

ERIC BELAJ 107148 May 31, 2017
Engineer's Name PE# Date

[Signature]
Engineer's Signature

SECTION

WASTEWATER

DETAIL NO.

WW-33

TITLE

MANDREL

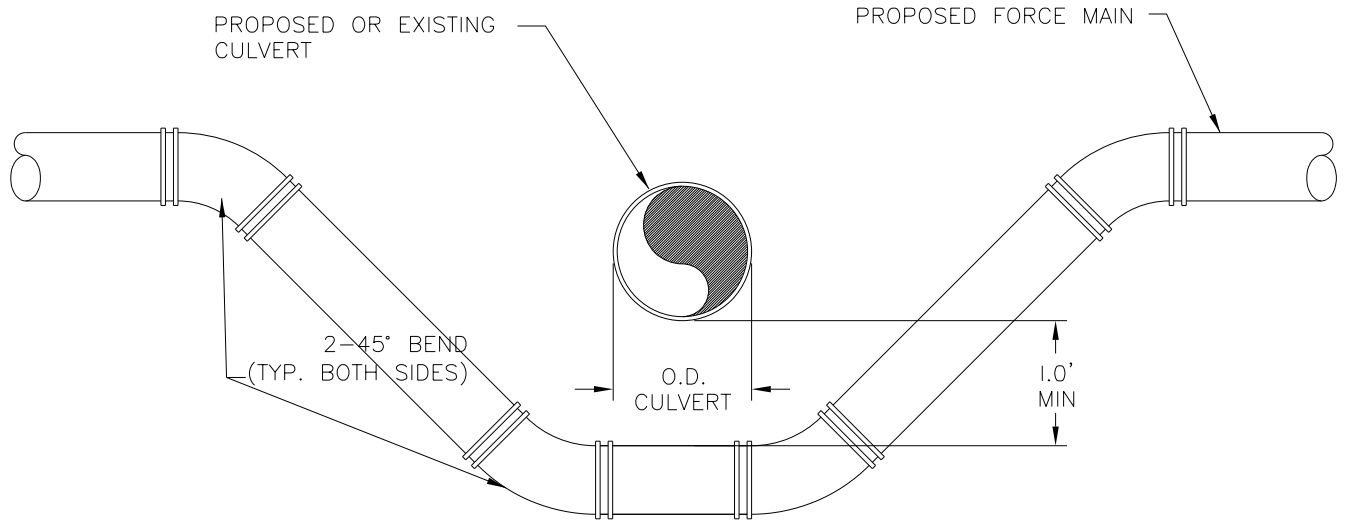

SCALE: NOT TO SCALE



MARBLE FALLS
800 THIRD STREET
MARBLE FALLS, TX 78654
PH: (830) 693-6737

These documents were prepared by,
or under the supervision of:

ERIC BELAJ 107148 May 31, 2017
Engineer's Name PE# Date

Engineer's Signature

SECTION

WASTEWATER

DETAIL NO.

WW-34

TITLE

FM CULVERT CROSSING

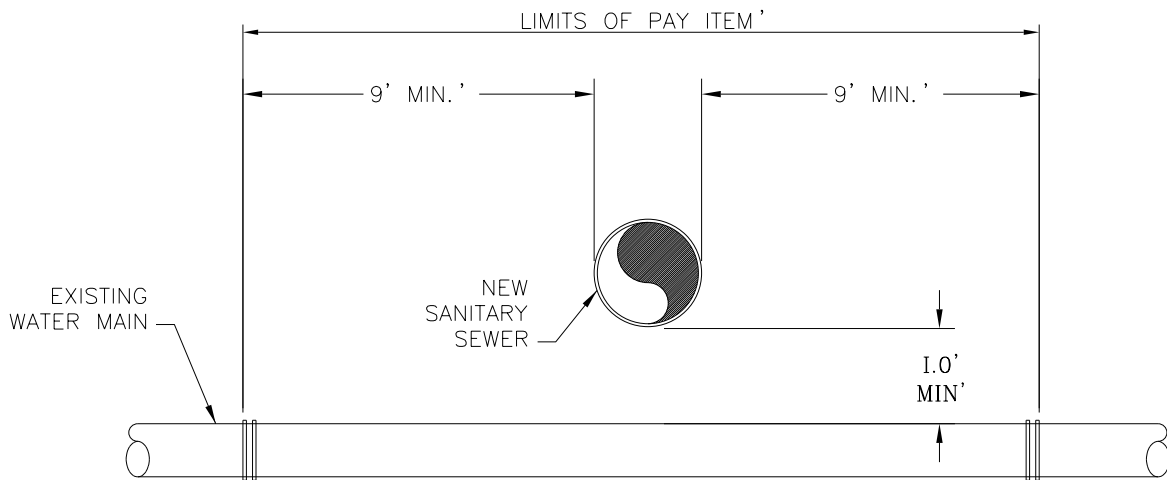

**** NOTE:**

1. SEWER PIPE SHALL BE SDR 21 W/ PRESSURE RATING OF 200 PSI WITH MECHANICAL JOINTS.
2. 1' MIN. SEPARATION, SEPERATE JOINTS AS FAR AS POSSIBLE FROM CROSSING.
3. CENTER ONE 18' MIN. JOINT OF SEWER LINE OVER CROSSING.
4. ALL CROSSINGS SHALL COMPLY WITH CURRENT TCEQ REQUIREMENTS AND IN ACCORDANCE W/AWWA & ASTM STANDARDS.
5. WHEN POSSIBLE, ALL SEWER LINES SHALL BE ROUTED BELOW WATER LINES.

SCALE: NOT TO SCALE



MARBLE FALLS
 800 THIRD STREET
 MARBLE FALLS, TX 78654
 PH: (830) 693-6737

These documents were prepared by,
 or under the supervision of:

ERIC BELAJ 107148 May 31, 2017
 Engineer's Name PE# Date

Engineer's Signature

SECTION

WASTEWATER

DETAIL NO.

WW-35

TITLE

PROPOSED WW OVER
 WATER MAIN CROSSING

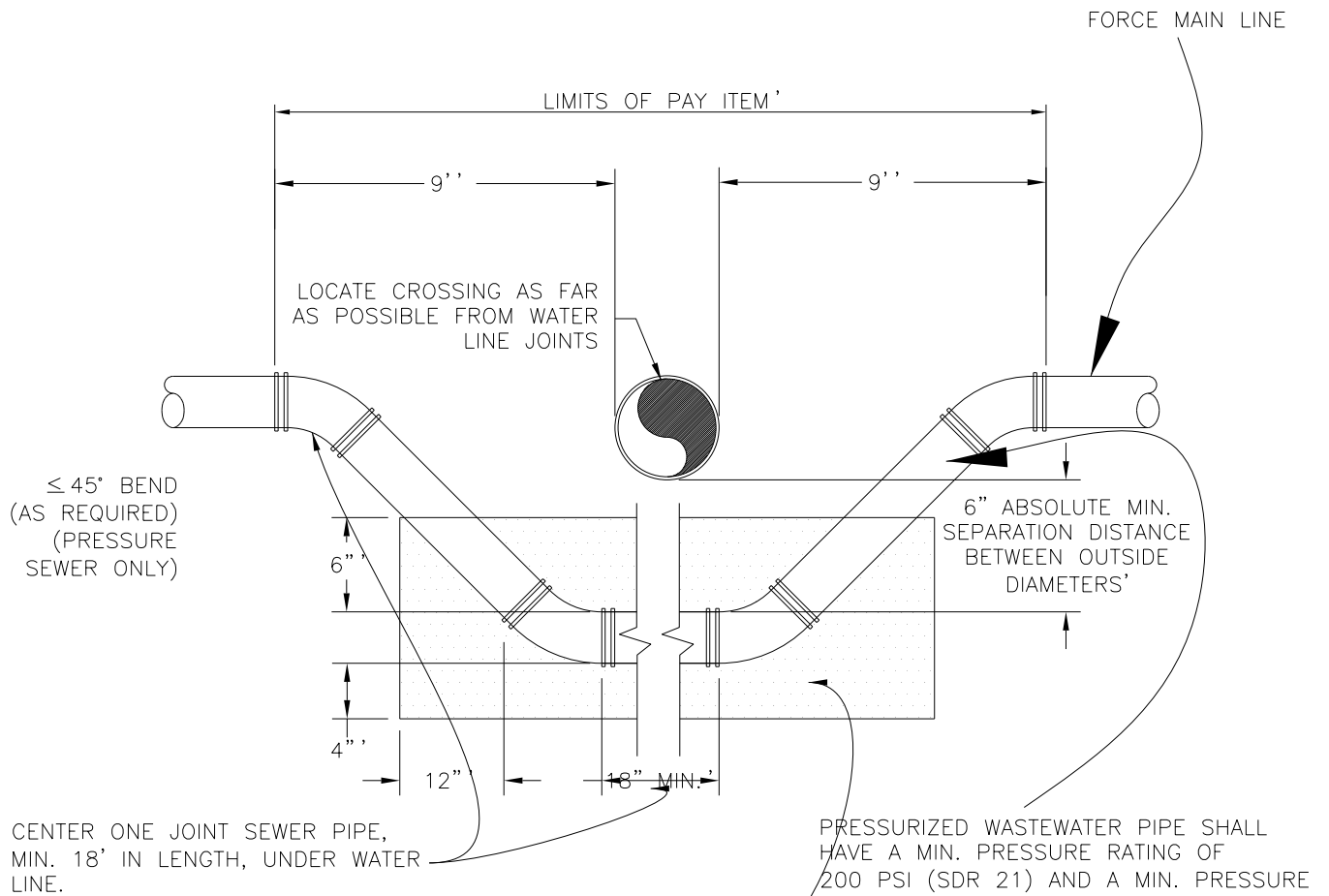

CENTER ONE JOINT SEWER PIPE, MIN. 18' IN LENGTH, UNDER WATER LINE.

PRESSURIZED WASTEWATER PIPE SHALL HAVE A MIN. PRESSURE RATING OF 200 PSI (SDR 21) AND A MIN. PRESSURE RATING OF 160 PSI (SDR 26) FOR GRAVITY SEWER.

BED SANITARY SEWER LINE IN BROWN COLORED CEMENT STABILIZED SAND WITH MINIMUM CEMENT CONTENT OF 2.5 BAGS OF CEMENT PER CUBIC YARD. CEMENT STABILIZED SAND SHALL BE PLACED 6" ABOVE AND 4" BELOW THE WASTEWATER LINE AND EXTEND THE TOTAL LENGTH OF ONE PIPE SEGMENT PLUS 12" BEYOND THE JOINT AT EACH END.

* ALL CROSSINGS SHALL COMPLY WITH CURRENT TCEQ REQUIREMENTS AND IN ACCORDANCE WITH AWWA AND/OR ASTM STANDARDS.

SCALE: NOT TO SCALE



MARBLE FALLS
800 THIRD STREET
MARBLE FALLS, TX 78654
PH: (830) 693-6737

These documents were prepared by,
or under the supervision of:

ERIC BELAJ 107148 May 31, 2017
Engineer's Name PE# Date

Engineer's Signature

SECTION
WASTEWATER

DETAIL NO.
WW-36

TITLE
PROPOSED FM UNDER
WATER MAIN CROSSING

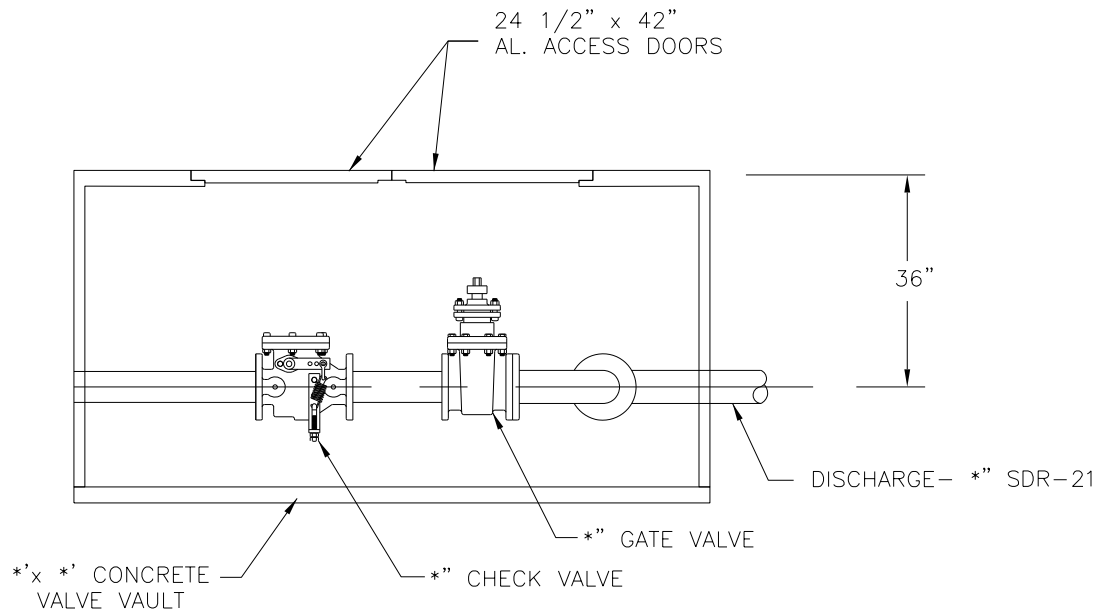

* SIZE AND TYPE TO BE
DETERMINED BY DESIGNER

SCALE: NOT TO SCALE



MARBLE FALLS
800 THIRD STREET
MARBLE FALLS, TX 78654
PH: (830) 693-6737

These documents were prepared by,
or under the supervision of:

ERIC BELAJ 107148 May 31, 2017
Engineer's Name PE# Date

Engineer's Signature

SECTION
WASTEWATER

DETAIL NO.
WW-37

TITLE
CHECK VALVE ASSEMBLY

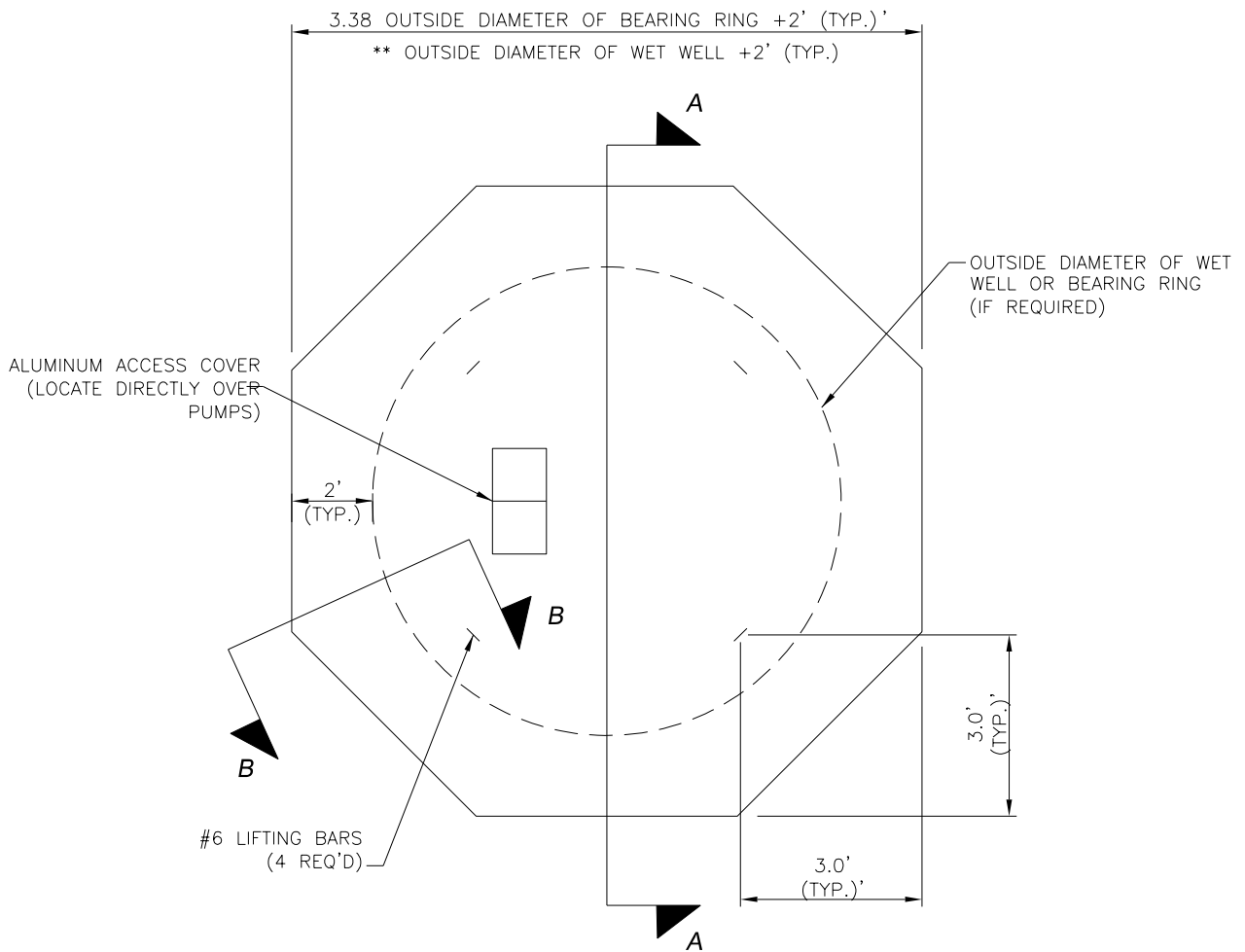

**LIFT STATION TOP
PLAN VIEW**

N.T.S.

- * REQUIRED IF FIBERGLASS WET WELL IS SPECIFIED, OR IF A BEARING RING IS CALLED FOR IN THE PLANS.
- ** IF NO BEARING RING IS REQUIRED.

SCALE: NOT TO SCALE



MARBLE FALLS
800 THIRD STREET
MARBLE FALLS, TX 78654
PH: (830) 693-6737

These documents were prepared by,
or under the supervision of:

ERIC BELAJ 107148 May 31, 2017
Engineer's Name PE# Date

Engineer's Signature

SECTION
WASTEWATER

DETAIL NO.
WW-38

TITLE
LIFT STATION TOP
PLAN VIEW (1 OF 3)

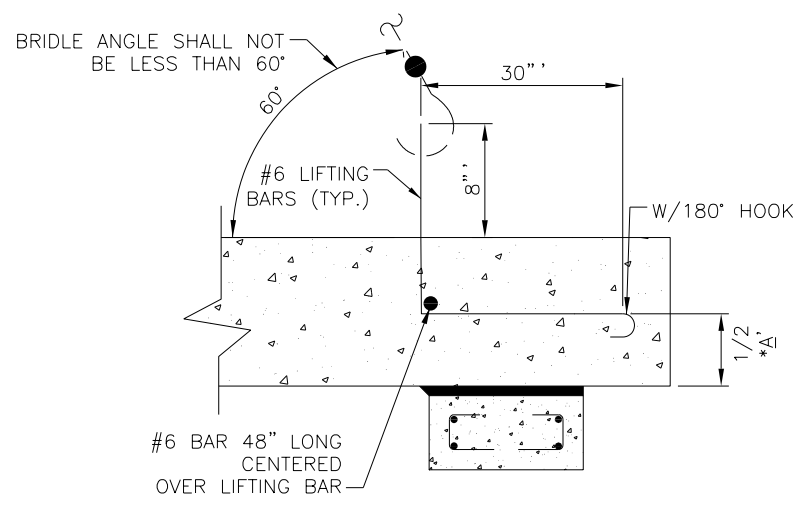
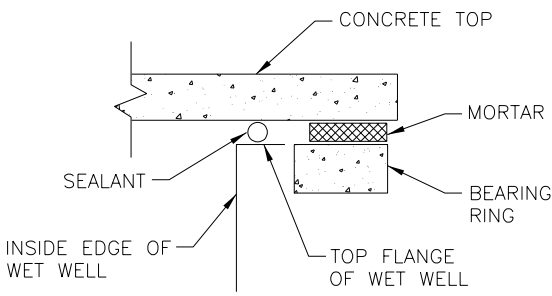
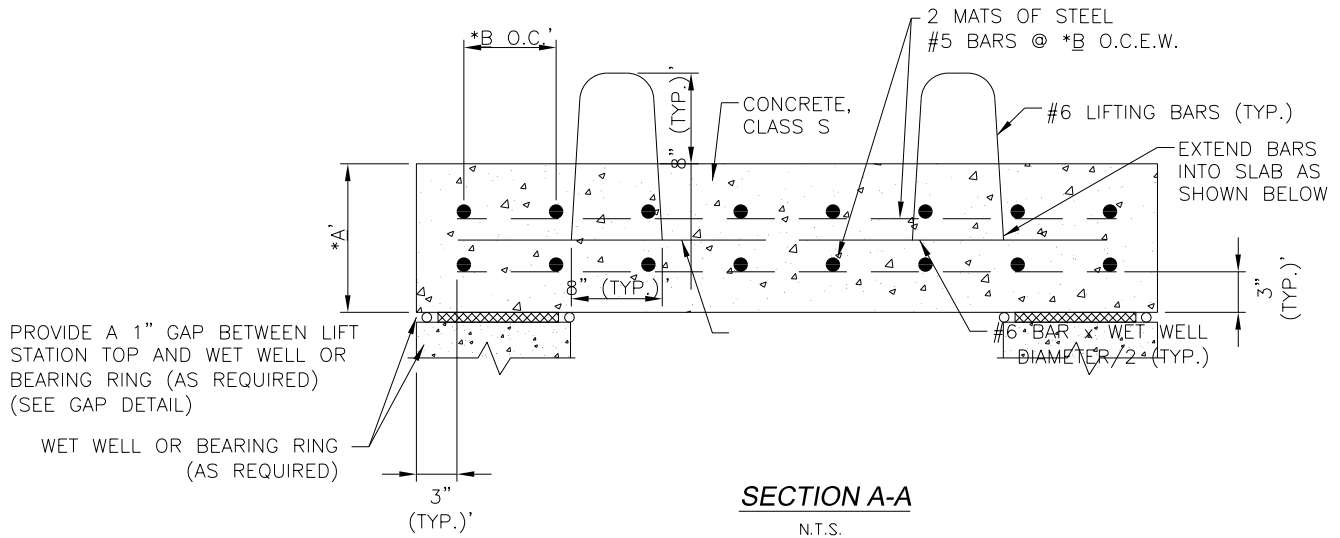

* DIMENSIONS		
LOCATION		
A		IN.
B		IN.

* DIMENSIONS FOR SLAB THICKNESS AND REINFORCING SCHEDULE IS SPECIFIC TO EACH USE AND MUST BE PROVIDED BY THE DESIGN ENGINEER.

SCALE: NOT TO SCALE



MARBLE FALLS
800 THIRD STREET
MARBLE FALLS, TX 78654
PH: (830) 693-6737

These documents were prepared by,
or under the supervision of:

ERIC BELAJ 107148 May 31, 2017
Engineer's Name PE# Date

[Signature]
Engineer's Signature

SECTION
WASTEWATER

DETAIL NO.
WW-39

TITLE
LIFT STATION TOP
BEARING RING (2 OF 3)

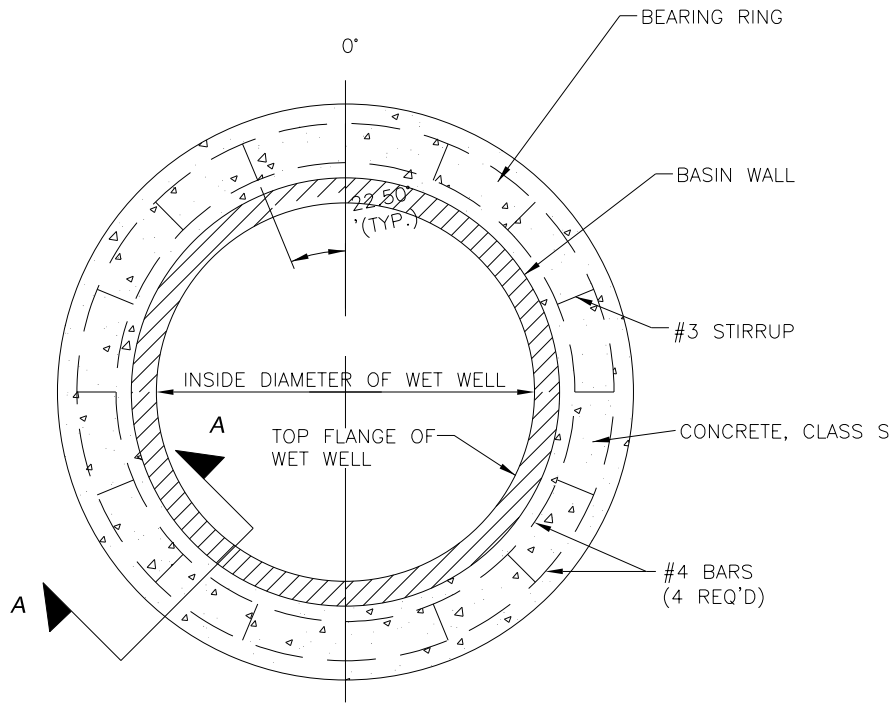

**BEARING RING
PLAN VIEW**

N.T.S.

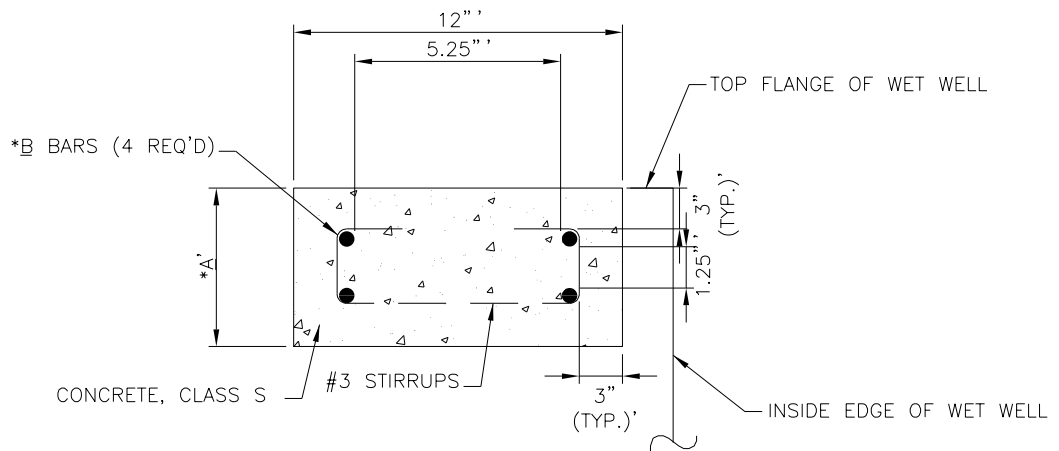

SECTION A-A

N.T.S.

* DIMENSIONS AND REINFORCING		
LOCATION		
A		IN.
B		BARS

* BEARING RING THICKNESS AND REINFORCING STEEL MUST BE SIZED BY THE DESIGN ENGINEER.

SCALE: NOT TO SCALE



MARBLE FALLS
800 THIRD STREET
MARBLE FALLS, TX 78654
PH: (830) 693-6737

These documents were prepared by,
or under the supervision of:

ERIC BELAJ 107148 May 31, 2017
Engineer's Name PE# Date

[Signature]
Engineer's Signature

SECTION
WASTEWATER

DETAIL NO.
WW-40

TITLE
LIFT STATION TOP
BEARING RING (3 OF 3)

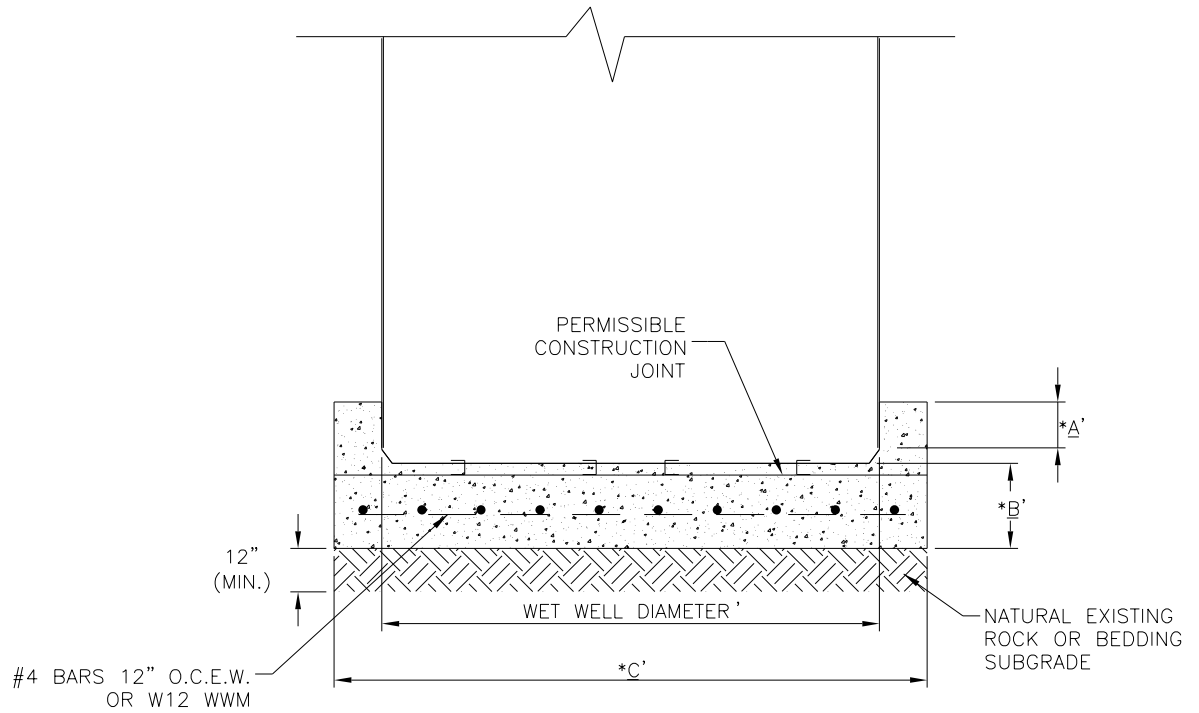

LIFT STATION FOUNDATION
ELEVATION VIEW
 N.T.S.

* DIMENSIONS		
LOCATION		
A		FT.
B		FT.
C		FT.

* DIMENSIONS FOR WET WELL FOUNDATION MUST BE PROVIDED BY THE DESIGN ENGINEER. DESIGN SHOULD PROVIDE FOR A FOUNDATION TO ADEQUATELY SUPPORT THE LIFT STATION AND PREVENT AGAINST FLOTATION.

SCALE: NOT TO SCALE



MARBLE FALLS
 800 THIRD STREET
 MARBLE FALLS, TX 78654
 PH: (830) 693-6737

These documents were prepared by,
 or under the supervision of:

ERIC BELAJ 107148 May 31, 2017
 Engineer's Name PE# Date

Engineer's Signature

SECTION
WASTEWATER

DETAIL NO.
WW-41

TITLE
 LIFT STATION FOUNDATION

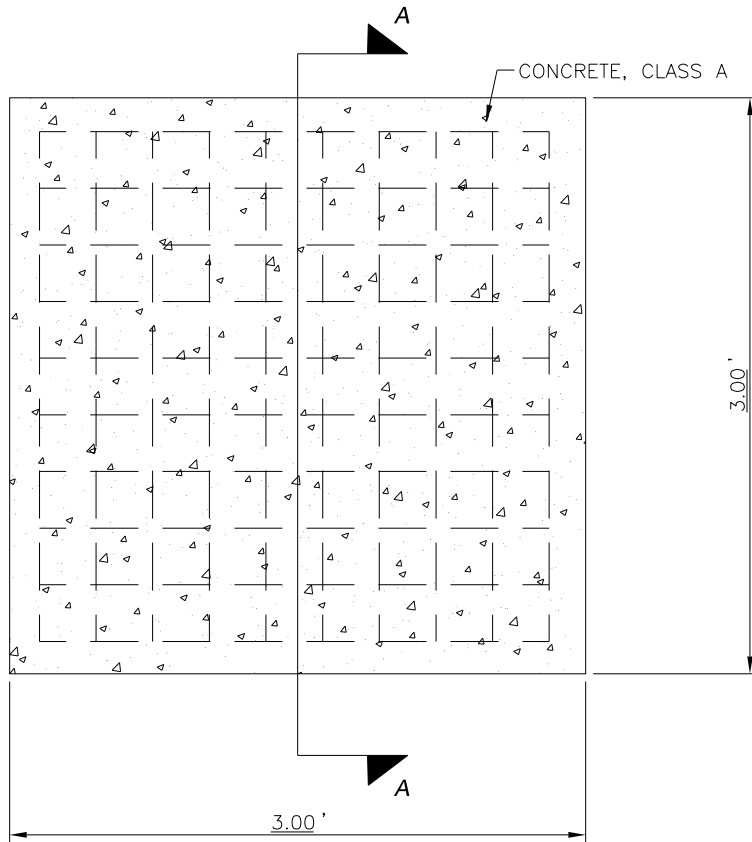

ODOR CONTROL SLAB
PLAN VIEW
 N.T.S.

* DIMENSIONS SHALL BE AS SPECIFIED BY THE ODOR CONTROL MANUFACTURER.

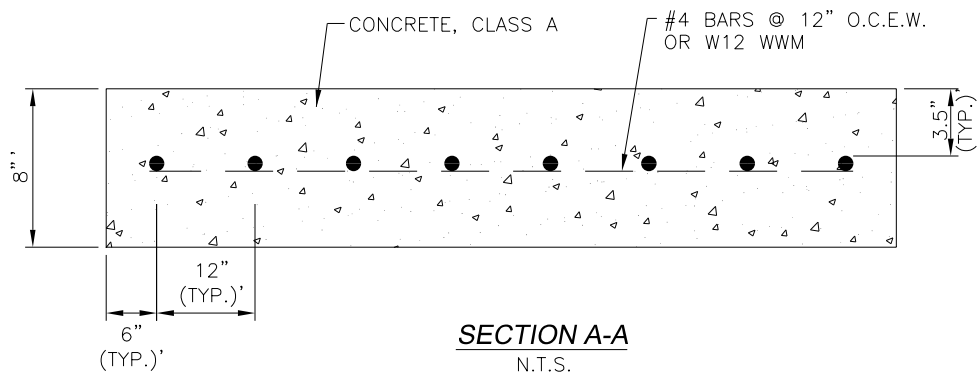

SECTION A-A
 N.T.S.

SCALE: NOT TO SCALE



MARBLE FALLS
 800 THIRD STREET
 MARBLE FALLS, TX 78654
 PH: (830) 693-6737

These documents were prepared by,
 or under the supervision of:

ERIC BELAJ 107148 May 31, 2017
 Engineer's Name PE# Date

Engineer's Signature

SECTION
WASTEWATER

DETAIL NO.
WW-42

TITLE
 ODOR CONTROL SLAB

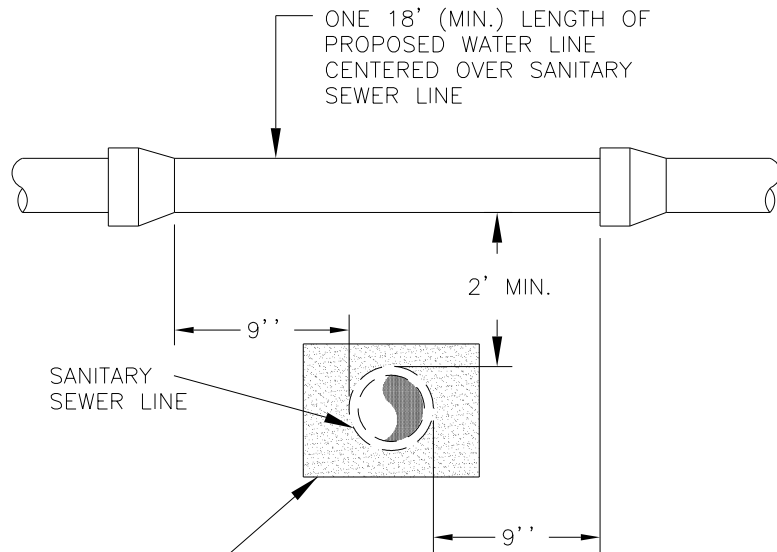

BED SANITARY SEWER LINE IN BROWN COLORED CEMENT STABILIZED SAND /MINIMUM CEMENT CONTENT OF 2.5 BAGS OF CEMENT PER CUBIC YARD. CEMENT STABILIZED SAND SHALL BE PLACED 6" ABOVE AND 4" BELOW THE WASTEWATER LINE.

*ALL CROSSINGS SHALL COMPLY WITH CURRENT TCEQ REQUIREMENTS.

SCALE: NOT TO SCALE



MARBLE FALLS
800 THIRD STREET
MARBLE FALLS, TX 78654
PH: (830) 693-6737

These documents were prepared by,
or under the supervision of:

ERIC BELAJ 107148 May 31, 2017
Engineer's Name PE# Date

Engineer's Signature

SECTION
WASTEWATER

DETAIL NO.
WW-43

TITLE
PROPOSED WW LINE
UNDER PROPOSED WATER

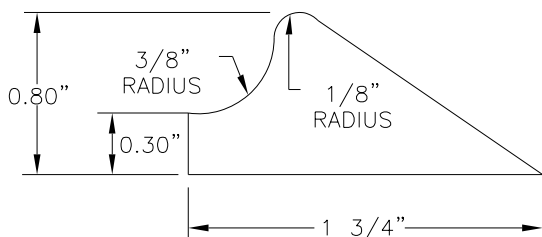
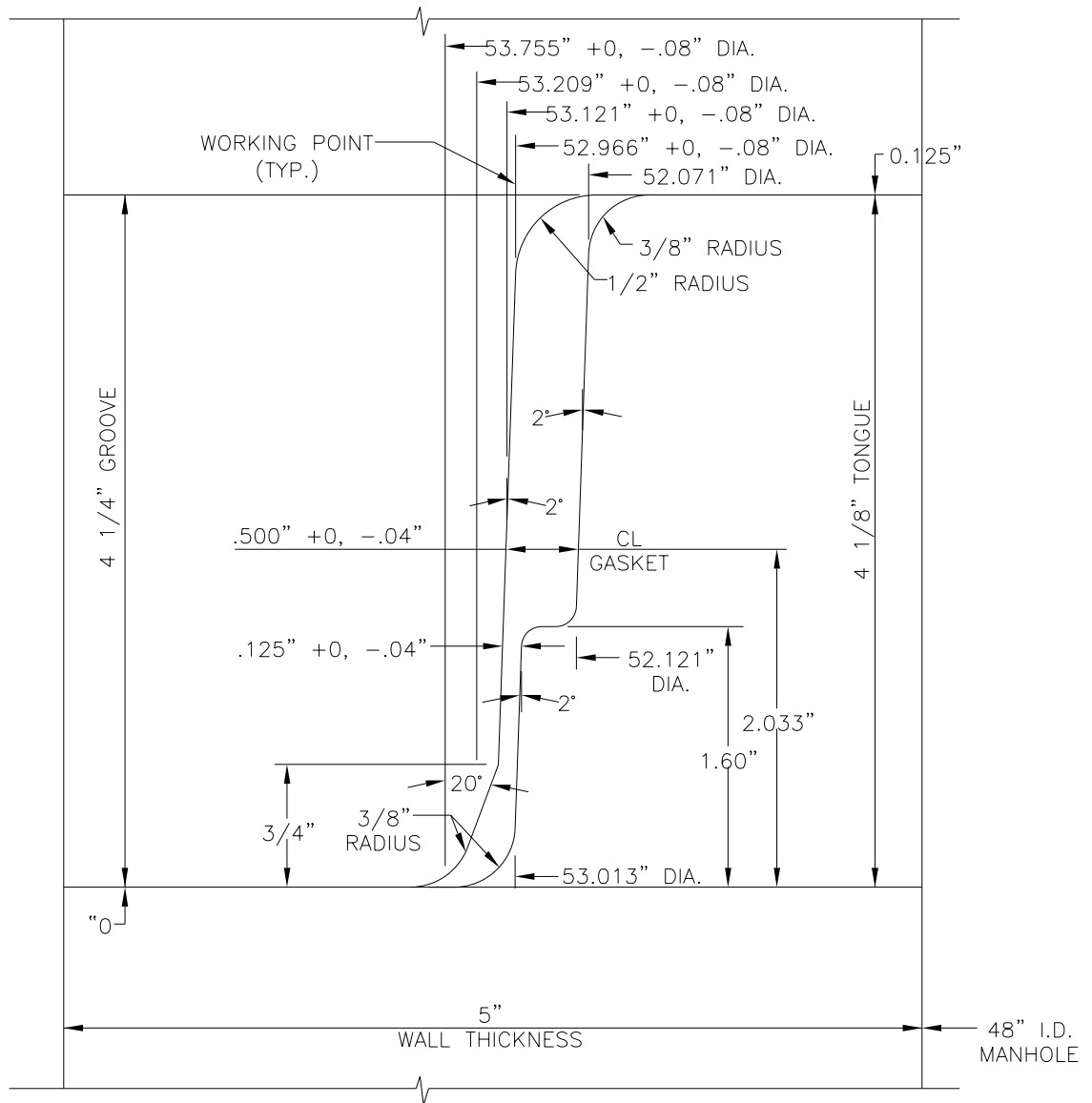

WEDGE TYPE GASKET
TYPICAL
DIMENSIONS

NOTES:

1. DRAWING NOT TO SCALE FOR CLARIFICATION OF DIMENSIONS.
2. GASKET STRETCH; MIN. 10, MAX. 15%.
3. ADAPTED FROM CITY OF AUSTIN 506S-13.

SCALE: NOT TO SCALE



MARBLE FALLS
800 THIRD STREET
MARBLE FALLS, TX 78654
PH: (830) 693-6737

These documents were prepared by,
or under the supervision of:

ERIC BELAJ 107148 May 31, 2017
Engineer's Name PE# Date

Engineer's Signature

SECTION

WASTEWATER

DETAIL NO.

WW-45

TITLE

MANHOLE
WEDGE SEAL JOINT

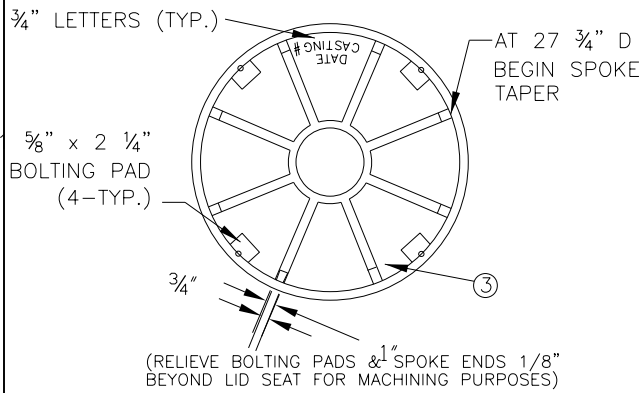

LID BOTTOM VIEW

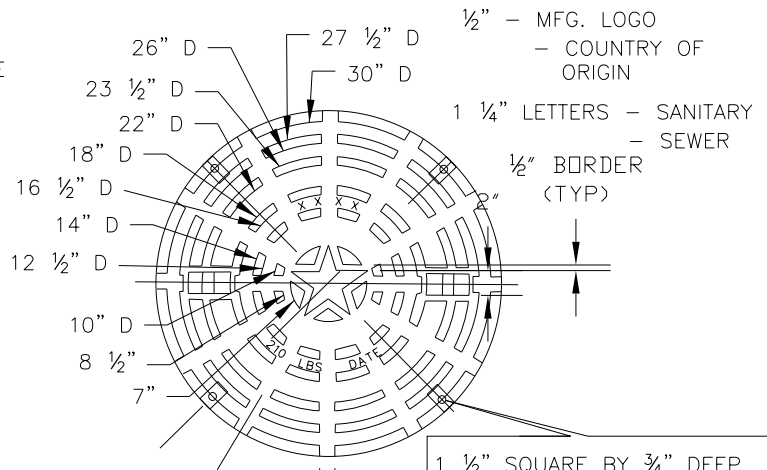

PLAN VIEW

1 1/2" SQUARE BY 3/4" DEEP RECESS BELOW TREAD WITH 1 3/16" HOLE ON A 29 13/16" DIA. CIRCLE(TYP.)

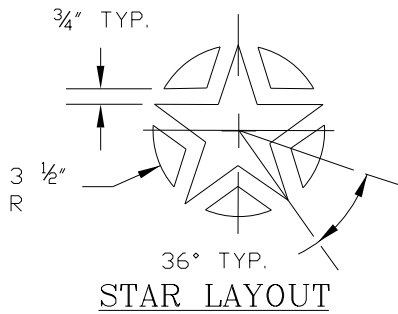

STAR LAYOUT

ALL MANHOLE LIDS SHALL BE BOLTED AND GASKETED

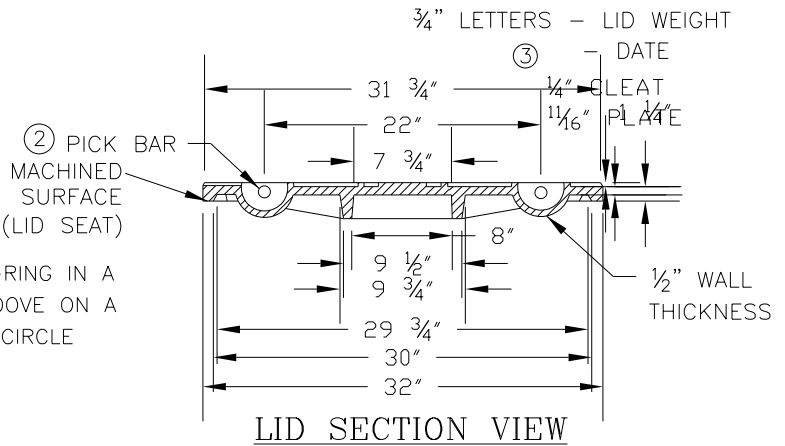

LID SECTION VIEW

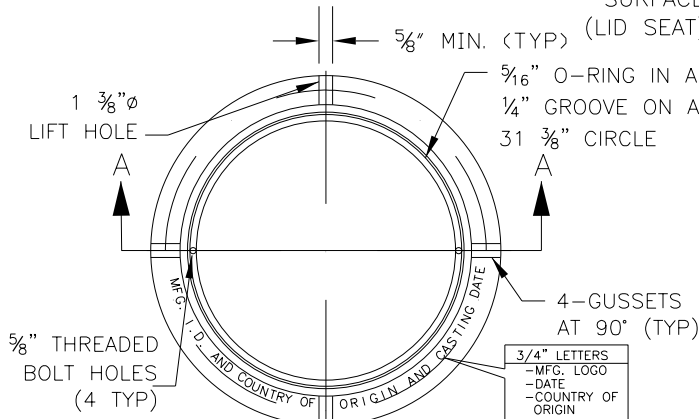

MANHOLE RING

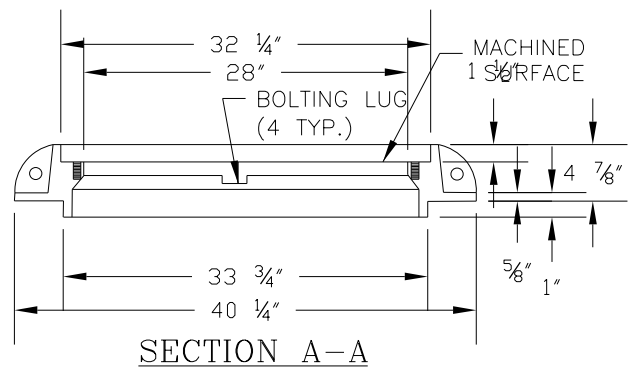

SECTION A-A

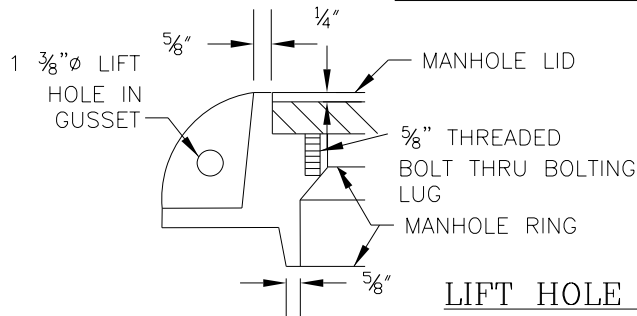

LIFT HOLE DETAIL

SCALE: NOT TO SCALE



MARBLE FALLS
 800 THIRD STREET
 MARBLE FALLS, TX 78654
 PH: (830) 693-6737

These documents were prepared by,
 or under the supervision of:

ERIC BELAJ 107148 May 31, 2017
 Engineer's Name PE# Date

[Handwritten Signature]
 Engineer's Signature

SECTION
WASTEWATER

DETAIL NO.
WW-46

TITLE
 MANHOLE
 SEALED FRAME & LID

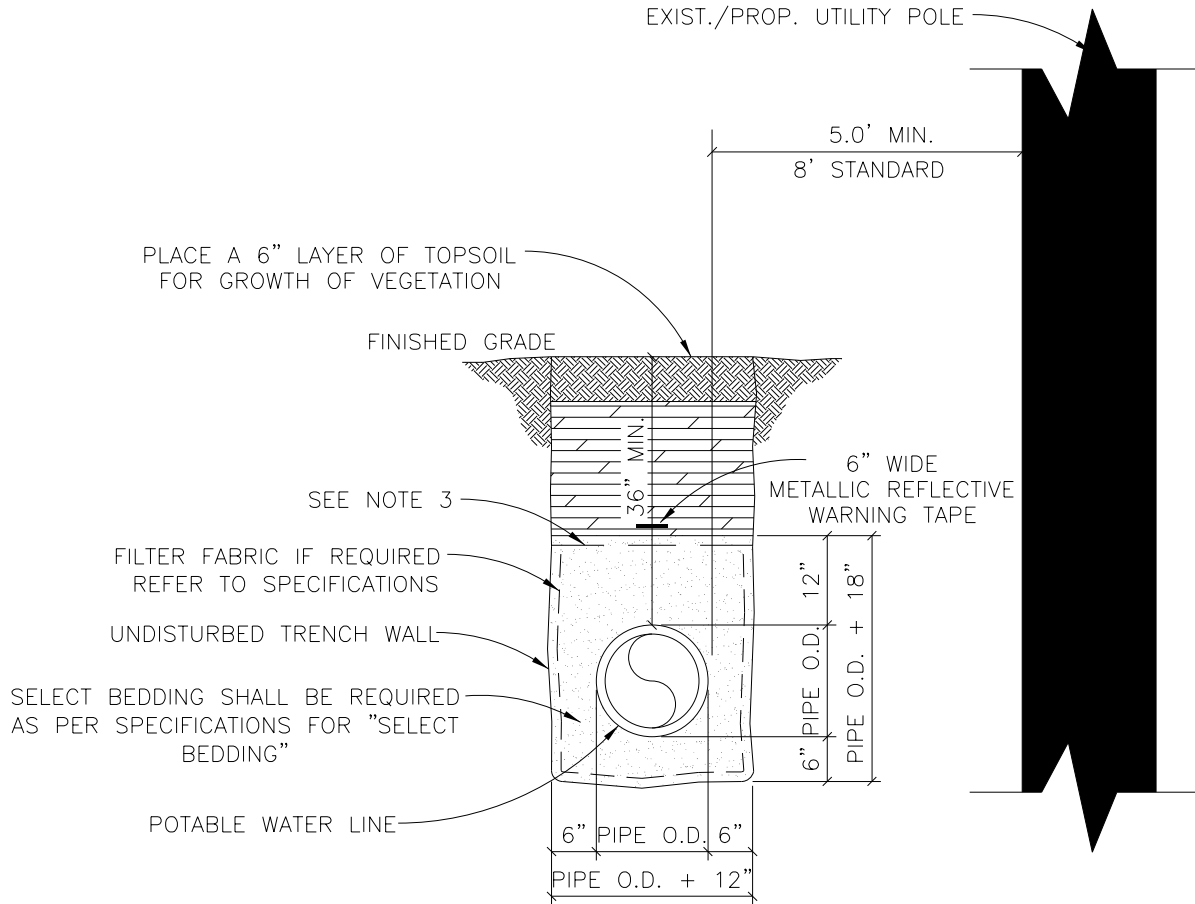

NOTES:

1. ALL CONDUIT TO INCLUDE A 1500 LB CONTINUOUS MULE TAPE IN PLACE BETWEEN PULL BOXES.
2. ALL INSTALLED CONDUITS MUST PASS A PULL TEST WITH A FULL SIZED MANDREL.
3. FILTER FABRIC ALONG THE TOP OF THE TRENCH IS REQUIRED REGARDLESS OF SUBSURFACE CONDITIONS.

SCALE: NOT TO SCALE



MARBLE FALLS
 800 THIRD STREET
 MARBLE FALLS, TX 78654
 PH: (830) 693-6737

These documents were prepared by,
 or under the supervision of:

ERIC BELAJ 107148 May 31, 2017
 Engineer's Name PE# Date

Engineer's Signature

SECTION

WATER

DETAIL NO.

WT-1

TITLE

EMBODIMENT UNDER
 UNPAVED AREAS

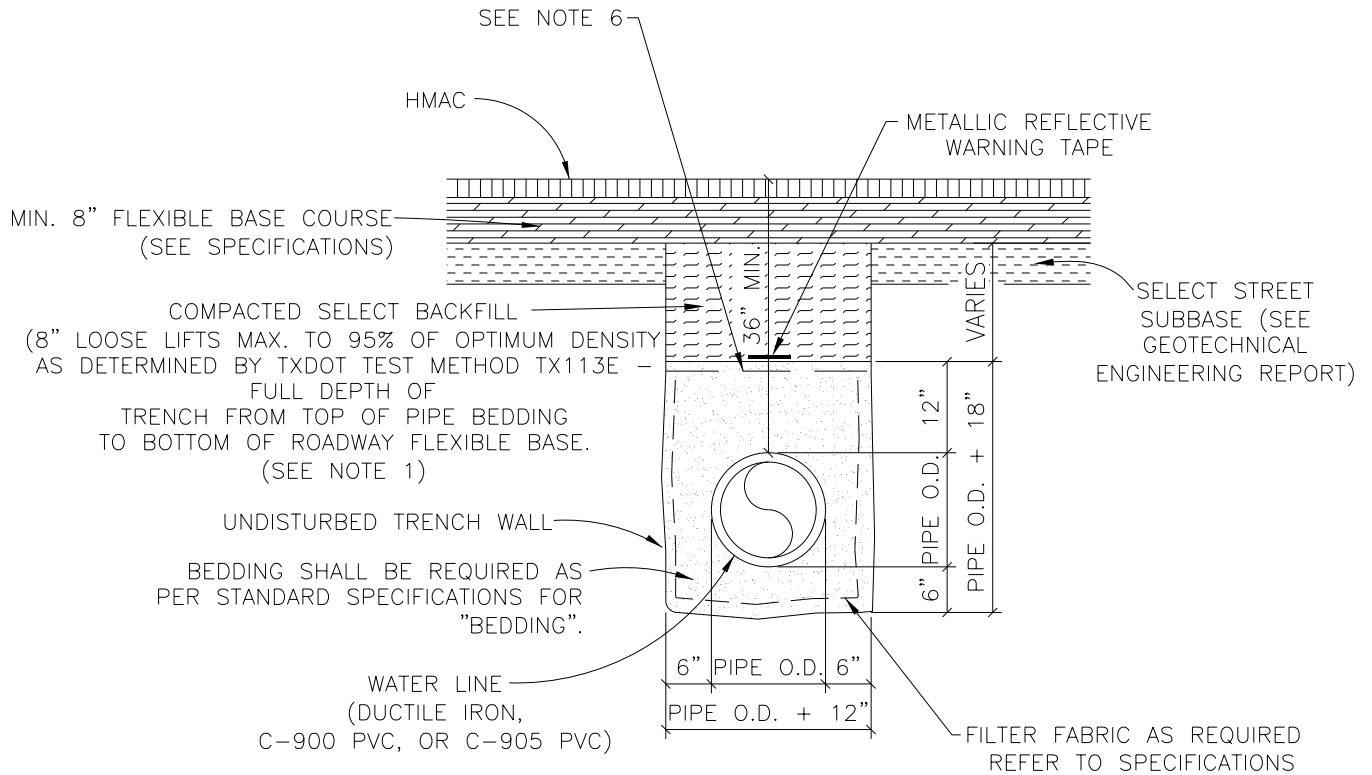

NOTES:

1. A MINIMUM OF ONE DENSITY TEST SHALL BE TAKEN EVERY TWO HUNDRED (200) FEET FOR EACH EIGHT (8) INCH LIFT OF SELECT BACKFILL. PROCTORS FOR MATERIALS USED IN BACKFILLING SHALL BE OBTAINED BY A CERTIFIED LABORATORY. DENSITY TESTS SHALL BE CONDUCTED BY A CERTIFIED LABORATORY OR THE PERMITTEE'S CONSULTANTS. ALL DENSITY TESTS SHALL BE COMPLETED AND ACCEPTED ON EACH LAYER PRIOR TO ADDITIONAL BACKFILLING. A COPY OF ALL COMPLETED AND ACCEPTED DENSITY TESTS SHALL BE FURNISHED TO THE OWNER. BACKFILL COMPACTION SHALL BE A MINIMUM 95% OF OPTIMUM DENSITY AS DETERMINED BY TXDOT 113E TEST METHOD.
2. CONTRACTOR OR ENGINEER MAY REQUEST FOR USE OF ALTERNATE BACKFILL MATERIAL. ALTERNATE MATERIALS AND TESTING PROTOCOL MUST BE SUBMITTED TO AND APPROVED BY THE CITY ENGINEER PRIOR TO USE.
3. REFER TO GEOTECHNICAL REPORT FOR ADDITIONAL SUBGRADE, FLEXIBLE BASE AND PAVEMENT REQUIREMENTS.
4. ALL COMMUNICATION CONDUIT TO INCLUDE A 1500 LB CONTINUOUS MULE TAPE IN PLACE BETWEEN PULL BOXES.
5. ALL INSTALLED CONDUITS MUST PASS A PULL TEST WITH A FULL SIZED MANDREL.
6. FILTER FABRIC ALONG THE TOP OF THE TRENCH IS REQUIRED REGARDLESS OF SUBSURFACE CONDITIONS.

SCALE: NOT TO SCALE



MARBLE FALLS
 800 THIRD STREET
 MARBLE FALLS, TX 78654
 PH: (830) 693-6737

These documents were prepared by,
 or under the supervision of:

ERIC BELAJ 107148 May 31, 2017
 Engineer's Name PE# Date

Engineer's Signature

SECTION

WATER

DETAIL NO.

WT-2

TITLE

EMBEDMENT UNDER
 PROPOSED PAVEMENT

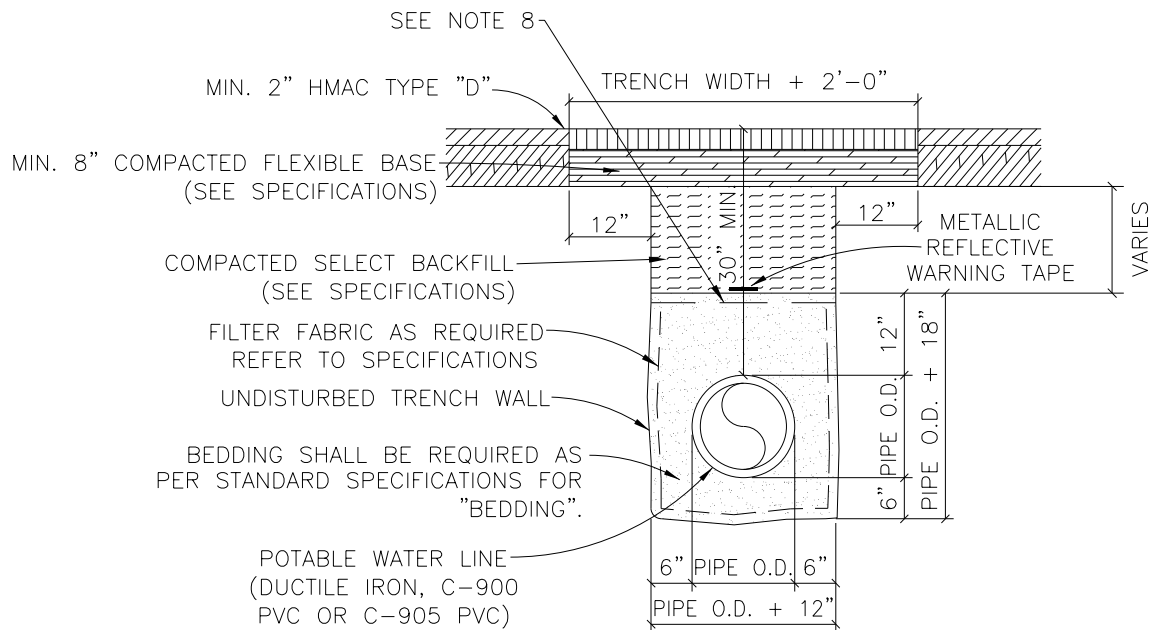

NOTES:

1. REPLACED BASE MATERIAL OVER DITCH SHALL BE A MINIMUM OF TWICE THE THICKNESS OF THE ORIGINAL BASE AND IN NO CASE LESS THAN 8".
2. BASE MATERIAL SHALL BE PLACED IN MAXIMUM 6" LIFTS AND EACH LIFT COMPACTED TO SPECIFIED DENSITY.
3. ASPHALT CONCRETE PAVEMENT JOINTS SHALL BE MECHANICALLY SAWED.
4. A MINIMUM OF ONE DENSITY TEST SHALL BE TAKEN EVERY TWO HUNDRED (200) FEET FOR EACH EIGHT (8) INCH LOOSE LIFT OF SUBGRADE AND EACH OPEN CUT CROSSING. ADDITIONAL TESTS MAY BE REQUIRED AT THE ENGINEER'S DISCRETION. ALL DENSITY TESTS SHALL BE COMPLETED AND ACCEPTED ON EACH LAYER PRIOR TO ADDITIONAL BACKFILLING. A COPY OF ALL COMPLETED AND ACCEPTED DENSITY TESTS SHALL BE FURNISHED TO THE OWNER.
5. CONTRACTOR OR ENGINEER MAY REQUEST FOR USE OF ALTERNATE BACKFILL MATERIAL. ALTERNATE MATERIALS AND TESTING PROTOCOL MUST BE SUBMITTED TO AND APPROVED BY THE CITY ENGINEER PRIOR TO USE.
6. ALL COMMUNICATION CONDUIT TO INCLUDE A 1500 LB CONTINUOUS MULE TAPE IN PLACE BETWEEN PULL BOXES.
7. ALL INSTALLED CONDUITS MUST PASS A PULL TEST WITH A FULL SIZED MANDREL.
8. FILTER FABRIC ALONG THE TOP OF THE TRENCH IS REQUIRED REGARDLESS OF SUBSURFACE CONDITIONS.

SCALE: NOT TO SCALE



MARBLE FALLS
800 THIRD STREET
MARBLE FALLS, TX 78654
PH: (830) 693-6737

These documents were prepared by,
or under the supervision of:

ERIC BELAJ 107148 May 31, 2017
Engineer's Name PE# Date

Engineer's Signature

SECTION

WATER

DETAIL NO.

WT-3

TITLE

EMBEDMENT UNDER
EXISTING PAVEMENT

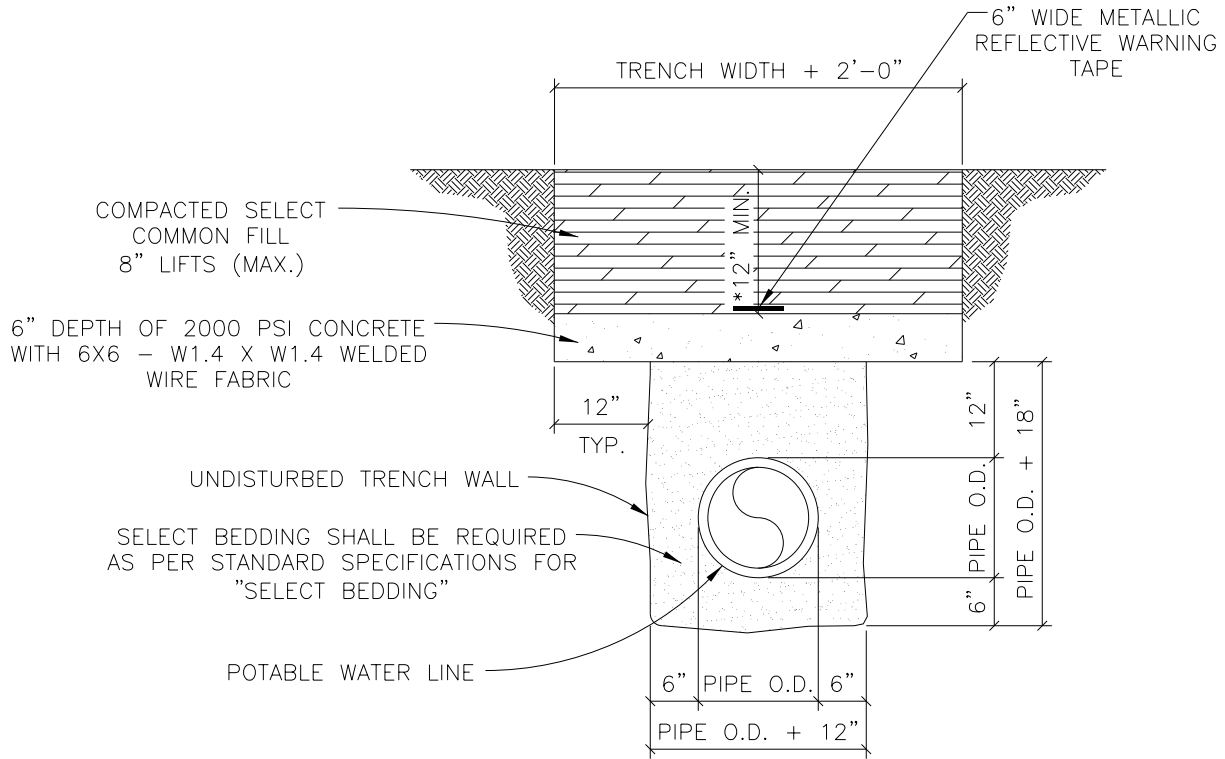

* WHERE 30" MINIMUM COVER CAN NOT BE OBTAINED OR DUE TO POTENTIAL SURFACE LOADING THE CITY MAY REQUIRE A CAP TO BE INSTALLED.

SCALE: NOT TO SCALE



MARBLE FALLS
800 THIRD STREET
MARBLE FALLS, TX 78654
PH: (830) 693-6737

These documents were prepared by,
or under the supervision of:

ERIC BELAJ 107148 May 31, 2017
Engineer's Name PE# Date

Engineer's Signature

SECTION

WATER

DETAIL NO.

WT-4

TITLE

CONCRETE CAP
EMBEDMENT

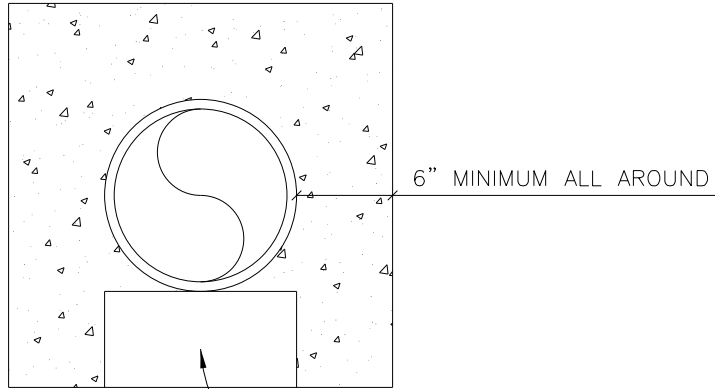

CONCRETE BLOCK OR BRICK SUPPORT
(MINIMUM OF TWO PER PIPE LENGTH)

NOTES:

1. ENCASEMENT TO BE CONSTRUCTED WHERE SEWER LINES PASS OVER OR UNDER A WATER MAIN WITH LESS THAN EIGHTEEN INCHES (18") CLEAR DISTANCE.
2. AT CROSSINGS, ENCASEMENT SHALL EXTEND TEN FEET (10'-0") ON EITHER SIDE OF CROSSING.
3. BEGINNING AND ENDING OF ENCASEMENTS SHALL NOT BE MORE THAN SIX INCHES (6") FROM A PIPE JOINT.
4. WHERE WATER AND SEWER LINES PARALLEL WITH LESS THAN TEN FEET (10'-0") HORIZONTAL CLEAR DISTANCE, NO ENCASEMENT IS REQUIRED IF BOTH LINES ARE 150 PRESSURE PIPE.
5. RAW WATER MAINS SHALL BE 150 PSI PRESSURE RATED WHEN PARALLELING POTABLE WATER MAINS WITH LESS THAN TEN FEET (10'-0") HORIZONTAL CLEARANCE.
6. WHERE MINIMUM COVER, THIRTY INCHES (30") IS NOT AVAILABLE, ENCASEMENT WILL BE REQUIRED.
7. ALL CONCRETE ENCASEMENTS MUST BE FORMED AND INSPECTED BY THE CITY OF MARBLE FALLS INSPECTOR PRIOR TO PLACING CONCRETE AND BACKFILLING.
8. CONCRETE SHALL BE FLOWABLE FILL HAVING A STRENGTH BETWEEN 300 TO 500 PSI.

SCALE: NOT TO SCALE



MARBLE FALLS
800 THIRD STREET
MARBLE FALLS, TX 78654
PH: (830) 693-6737

These documents were prepared by,
or under the supervision of:

ERIC BELAJ 107148 May 31, 2017
Engineer's Name PE# Date

Engineer's Signature

SECTION

WATER

DETAIL NO.

WT-5

TITLE

CONCRETE ENCASED PIPE

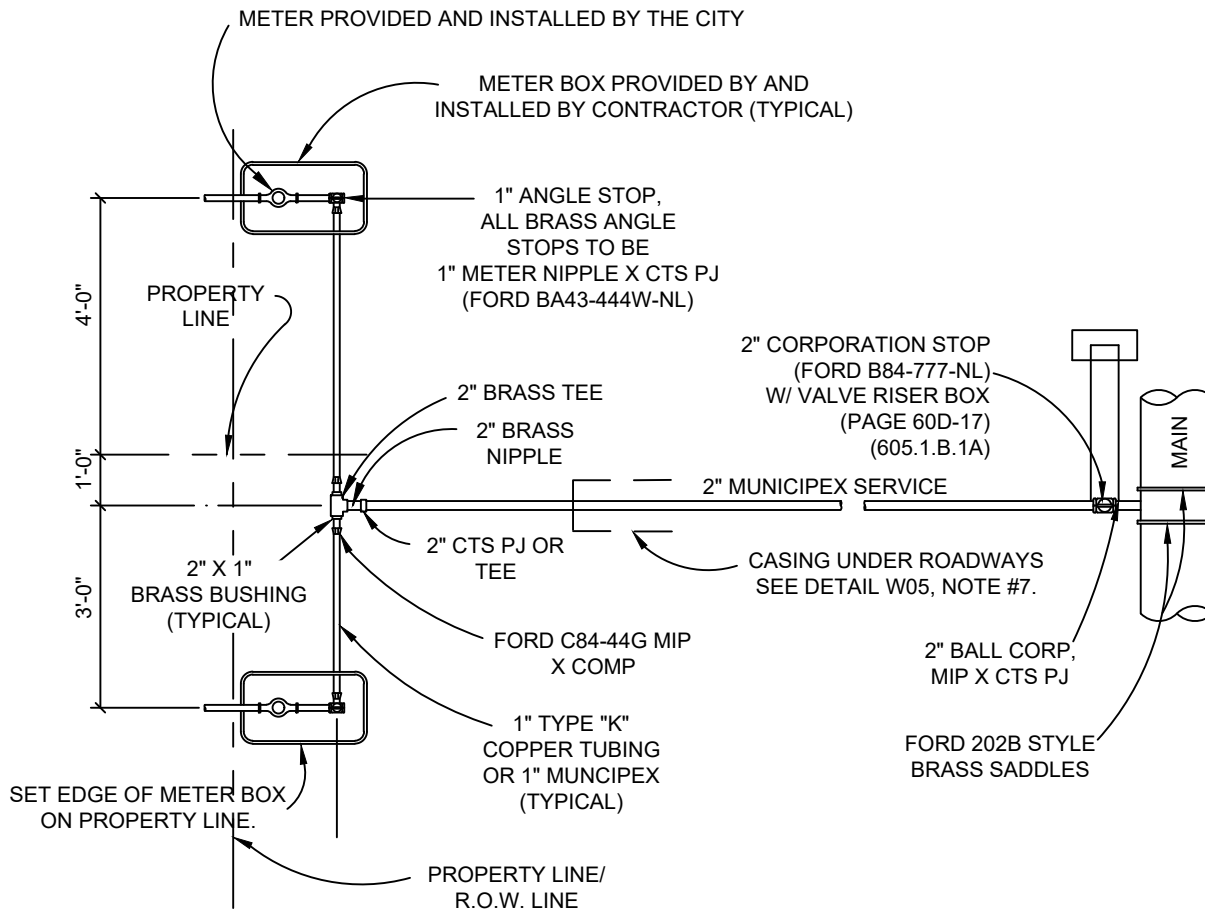

NOTES:

1. AUTHORIZED SERVICE LINE MATERIAL (2" DIAMETER): 2" MUNICIPEX, 250 PSI
 - A. BLUE MUNICIPEX (2" DIAMETER) 250 PSI - MAIN LINE TO 2" TEE (FORD T444-774-AWT-NL).
 - B. TYPE "K" COPPER (1" DIAMETER) - 2" TEE (FORD T444-774-AWT-NL) TO METER
2. ANGLE STOP SHALL BE 1" MINIMUM, FORD BRASS ONLY.
3. 1" ANGLE STOPS WITH 3/4" VALVES SHALL NOT BE PERMITTED.
4. MULTIPLE SERVICE/METER INSTALLATIONS OF MORE THAN 4 METERS PER SERVICE AND SERVICE LINES LARGER THAN 2" IN DIAMETER SHALL BE HANDLED ON AN INDIVIDUAL BASIS.
5. ANGLE STOPS 1 1/2" AND 2" IN SIZE SHALL BE PROVIDED WITH BOTH A LOCKING CAP AND METER FLANGE.
6. THERE SHALL BE A 6" ENVELOPE OF SAND AROUND ALL SERVICE AND CASING PIPE. COMPACT BACKFILL ON LONG SERVICES UNDER ROADWAYS PER SPECIFICATIONS.
7. CASING REQUIREMENTS FOR SERVICE LINES CROSSING ROADWAYS SEE DETAIL LONG SINGLE & DOUBLE WATER SERVICE SECTION.
8. ANY VARIATIONS ON FITTINGS MUST BE APPROVED BY THE MARBLE FALLS PUBLIC WORKS DEPARTMENT.
9. METER BOX TO BE SOLID PLASTIC WITH BLACK CAST IRON LID AND FLIP LID FOR METER READING. MODEL NO. 36 MANUFACTURED BY MID-AMERICAN RESEARCH CHEMICAL CORPORATION OR APPROVED EQUAL.

SCALE: NOT TO SCALE



MARBLE FALLS

800 THIRD STREET
MARBLE FALLS, TX 78654

PH: (830) 693-6737

These documents were prepared by,
or under the supervision of:

Kacey Cubine Paul 120200 June 6, 2023
Engineer's Name PE# Date

Engineer's Signature

SECTION

WATER

DETAIL NO.

WT-6

TITLE

DOUBLE SERVICE PLAN

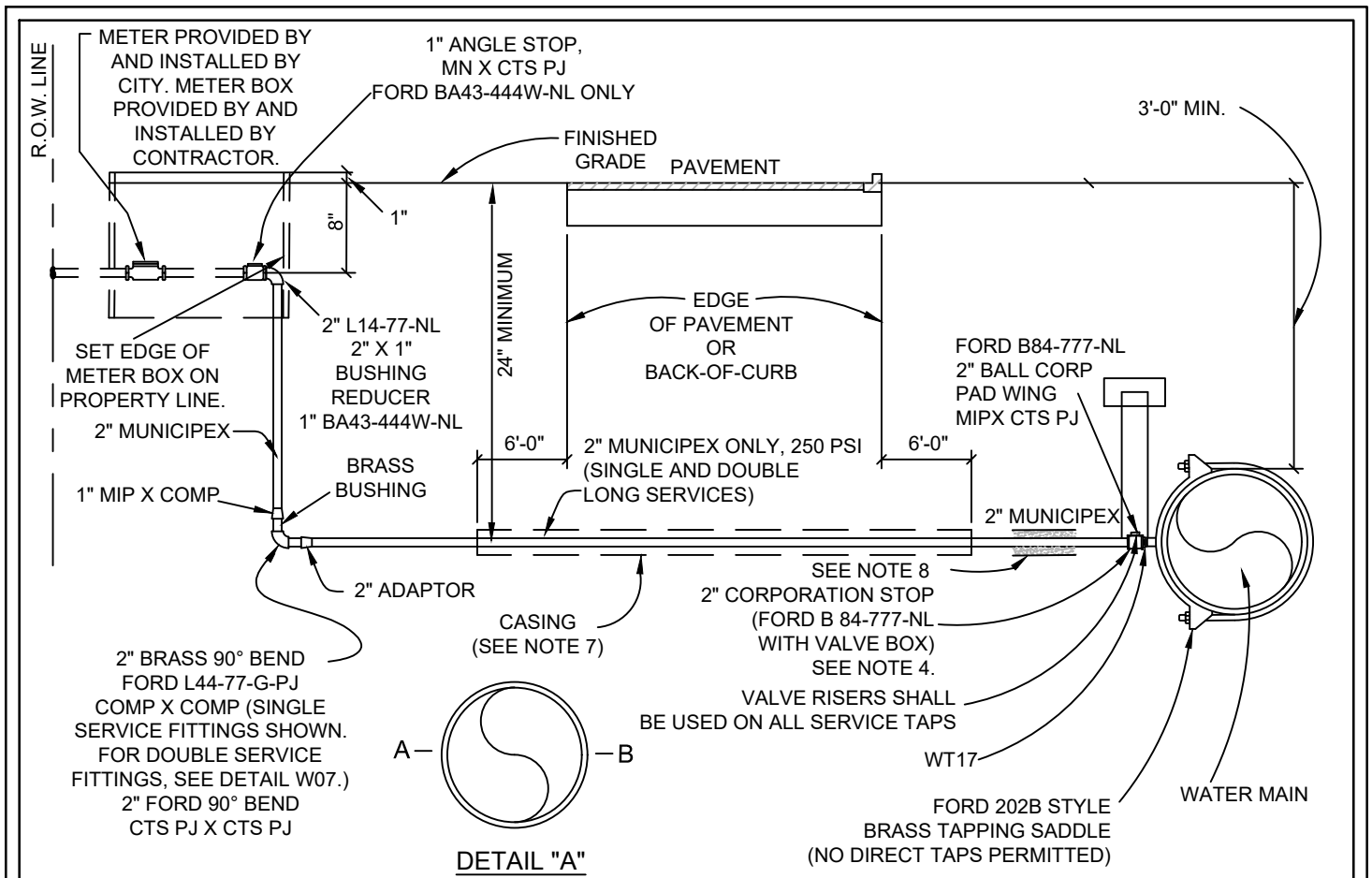

NOTES:

1. SUCCESSIVE TAPS INTO THE WATER MAIN SHALL BE SPACED A MINIMUM OF 18" OFFSET AND AT THE CENTERLINE AS SHOWN ON DETAIL "A".
2. THE TOP OF METER BOX SHALL BE SET 1" ABOVE FINISHED GRADE.
3. AUTHORIZED SERVICE LINE MATERIAL:
 - A. TYPE "K" COPPER (1" DIAMETER) FROM 2" X 1" BUSHING TO METER BOX.
 - B. BLUE MUNICIPEX (1"- 2" DIAMETER) 250 PSI - FROM MAIN TO 2" X 1" BUSHING.
4. ROTATE THE CORPORATION STOP SO THAT THE OPERATING NUT IS ACTUATED FROM THE VERTICAL POSITION RATHER THAN THE HORIZONTAL.
5. SERVICE LINES SHALL BE CONTINUOUS FROM CORPORATION STOP TO 2" BRASS 90° BEND OR 2" BRASS TEE WITH NO FITTINGS IN BETWEEN.
6. SERVICE CASING SHALL NOT BE INSTALLED BY WATER JETTING UNDER ROADWAY.
7. CASING REQUIRED FOR ALL PAVEMENT CROSSINGS. 4" SH-40, BLUE, WHITE, OR BLACK, REQUIRED FOR OPEN-CUT. GALVANIZED CASING PIPE REQUIRED FOR JACK AND BORE. LIMITS OF CASING SHOULD EXTEND SIX FEET BEYOND THE EDGE OF PAVEMENT OR BACK-OF-CURB.
8. THERE SHALL BE A 6" ENVELOPE OF 3/8" ROCK OR APPROVED BEDDING SAND AROUND ALL SERVICE AND CASING PIPE. COMPACT BACKFILL ON LONG SERVICES UNDER ROADWAYS PER STANDARD DETAIL W03 OR W04.
9. ANY VARIATIONS ON FITTINGS MUST BE APPROVED BY THE MARBLE FALLS PUBLIC WORKS DEPARTMENT.
10. METER BOX TO BE SOLID BLACK PLASTIC WITH BLACK CAST IRON LID AND FLIP LID FOR METER READING. MODEL NO. MB-16L OR LL MANUFACTURED BY RHINO WITH HINGED READER LID OR APPROVED EQUAL.
11. CORPORATION STOPS, ANGLE STOPS AND OTHER BRASS FITTINGS SHALL BE MANUFACTURED BY FORD, OR APPROVED EQUAL.

SCALE: NOT TO SCALE



MARBLE FALLS

800 THIRD STREET
MARBLE FALLS, TX 78654

PH: (830) 693-6737

These documents were prepared by,
or under the supervision of:

Kacey Cubine Paul 120200 June 6, 2023
Engineer's Name PE# Date

Engineer's Signature

SECTION

WATER

DETAIL NO.

WT-7

TITLE

DOUBLE SERVICE SECTION

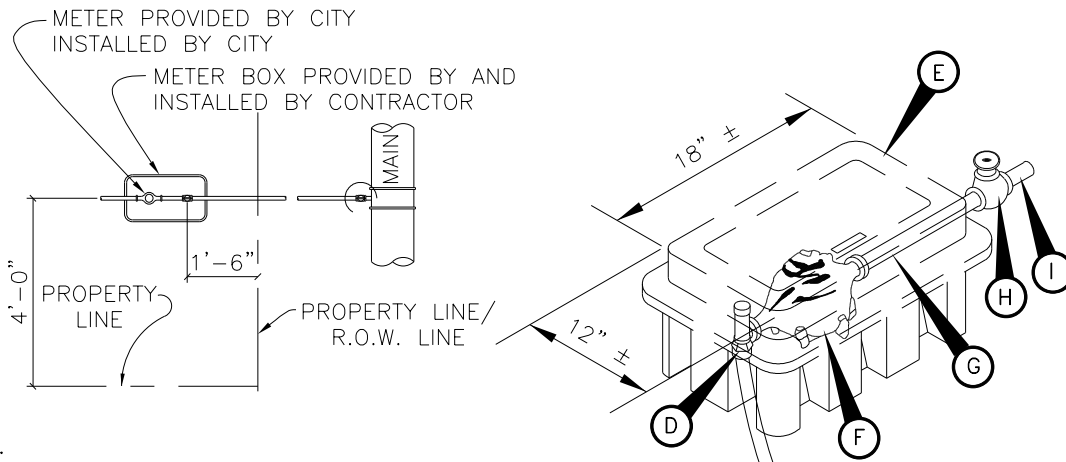

NOTES:

1. SERVICE PIPE SHALL BE COPPER TUBE SIZE. IT SHALL BE 150 PSI ANNEALED SEAMLESS TYPE "K" COPPER TUBING.
2. SERVICE SADDLES SHALL BE WRAPPED COMPLETELY WITH 8 mil. POLYETHYLENE FILM.
3. TOP OF BOXES SHALL BE 1 INCH ABOVE FINISHED GRADE.
4. SERVICE TUBING SHALL BE INSTALLED WITH A 6 INCH ENVELOPE OF BEDDING SAND OR 3/8" ROCK AROUND TUBING.
5. METER BOX TO BE SOLID BLACK PLASTIC WITH BLACK LID AND FLAP FOR METER READING, RHINO MB-16L OR LL MODEL, OR APPROVED EQUAL (SUPPLIER/MANUFACTURER).
6. ANY VARIATIONS ON FITTINGS MUST BE APPROVED BY THE CITY ENGINEER.
7. AXIS OF METER ASSEMBLY (METER STOP, METER, PIPING AND OWNERS CUTOFF) SHALL BE 10" BELOW TOP OF BOX.
8. SLOTS PROVIDED IN METER BOX TO ACCOMMODATE PIPING INTO AND OUT OF BOX SHALL NOT BE MODIFIED.

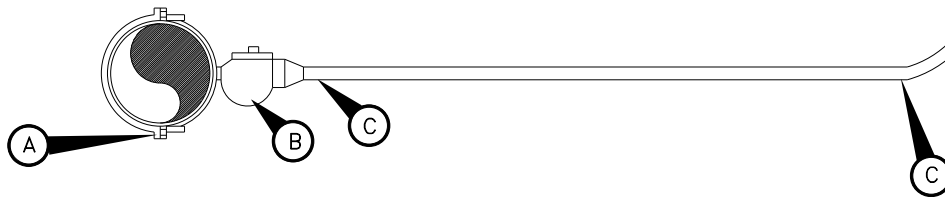

MATERIAL LIST

- A. FORD BRASS SADDLE -- SERVICE CLAMP REQUIRED.
- B. 1" CORPORATION STOP -- SERVICE PIPE OUTLET.
- C. 1" SERVICE PIPE. WATER SERVICE CASING IS REQUIRED FOR SERVICE LINES CROSSING UNDER ROADWAYS. SEE DETAIL W-03, NOTE #7.
- D. ANGLE METER STOP; SERVICE PIPE INLET X SWIVEL COUPLING NUT OUTLET:
 - FOR 5/8" AND 3/4" METERS: 1" x 3/4"
 - FOR 1" METERS: 1" x 1"
- E. JONES *J-1965 W WITH JONES J-130 SPUD
- F. PLASTIC RECTANGULAR METER BOX (SEE NOTE 5).

NOT STANDARD

METER SIZE	LENGTH
5/8"	7 3/4"
3/4"	9"
1"	11"

NOTE: F THRU I TO BE INSTALLED UNDER SEPARATE BUILDING PERMIT.

- F. WATER METER -- FURNISHED AND INSTALLED BY CITY
- G. WATER METER COUPLING; MALE I.P.T. X SWIVEL COUPLING NUT:
 - FOR 5/8" AND 3/4" METERS: 3/4" x 8 1/2" LONG. - FOR 1" METERS: 1" x 8 1/2" LONG.
- H. BRASS GATE VALVE; NON-RISING STEM 1" FEMALE I.P.T. (PROPERTY OWNERS CUT-OFF OUTSIDE METER BOX IN SEPARATE VALVE CAN WITH LID AS PER STANDARDS).
- I. 1" PIPE (SCH. 40 PVC) BY PROPERTY OWNER

SCALE: NOT TO SCALE



MARBLE FALLS
 800 THIRD STREET
 MARBLE FALLS, TX 78654
 PH: (830) 693-6737

These documents were prepared by,
 or under the supervision of:

ERIC BELAJ 107148 May 31, 2017
 Engineer's Name PE# Date

[Signature]
 Engineer's Signature

SECTION

WATER

DETAIL NO.

WT-8

TITLE

SINGLE 3/4" TO 1" SERVICE

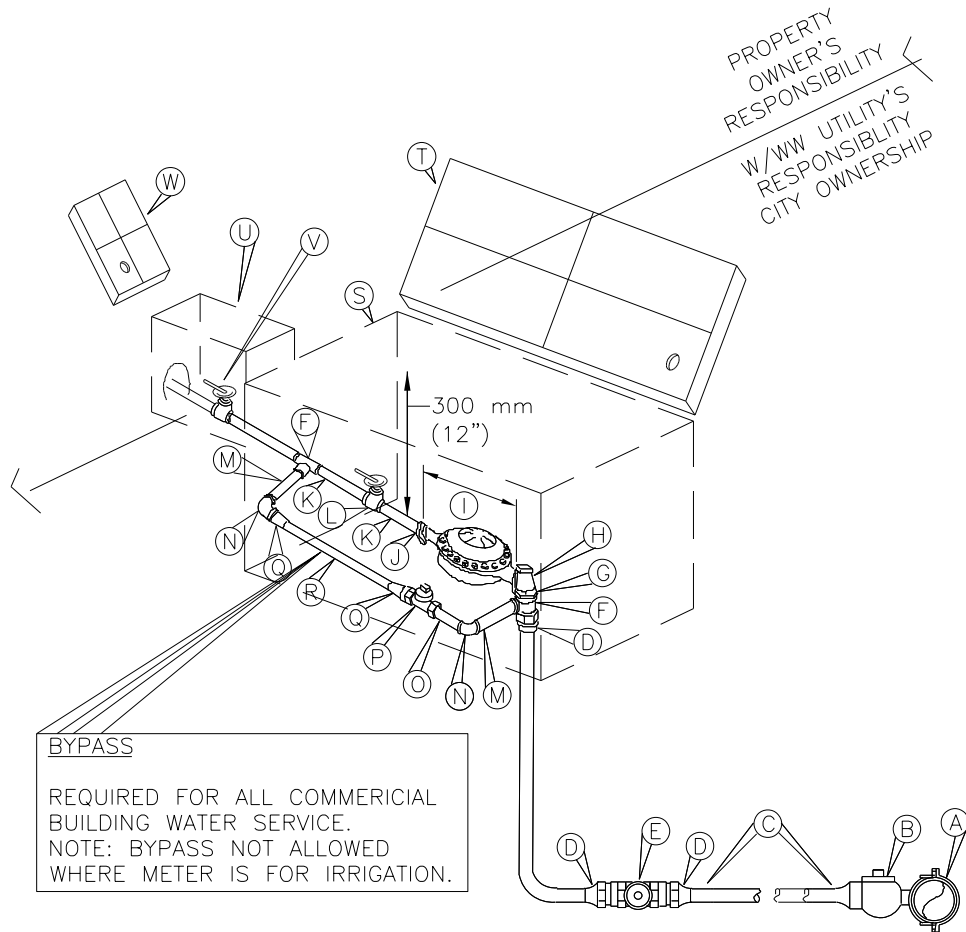

NOTES:

1. SERVICE PIPE SHALL BE COPPER TUBE SIZE. IT SHALL BE ANNEALED SEAMLESS TYPE "K" COPPER TUBING MEETING THE CURRENT ASTM B88 STANDARD WITH NO SWEAT OR SOLDERED JOINTS.
2. SERVICE SADDLE SHALL BE WRAPPED COMPLETELY WITH 0.2 mm (8 MIL) POLYETHYLENE FILM.
3. TOP OF BOXES SHOULD BE 25 mm (1") ABOVE GROUND OR FLUSH WITH PAVEMENT SURFACE.
4. PIPING AND TUBING IN STREET RIGHT-OF-WAY SHALL BE BEDDED IN GRANULAR MATERIALS.
5. BOX MUST BE BEHIND CURB NOT TO PROPERTY LINE OR EASEMENT AND OUT OF SIDEWALK AND OUT OF VEHICULAR TRAFFIC AREA.
6. IF POLYETHYLENE TUBING IS USED, COMPRESSION FITTING REQUIRED WITH STEEL PIPE STIFFNER INSERT.

NOTES:

1. DRAWING NOT TO SCALE FOR CLARIFICATION OF DIMENSIONS.
2. ADAPTED FROM CITY OF AUSTIN 520S-13.

SCALE: NOT TO SCALE



MARBLE FALLS
 800 THIRD STREET
 MARBLE FALLS, TX 78654
 PH: (830) 693-6737

These documents were prepared by,
 or under the supervision of:

ERIC BELAJ 107148 May 31, 2017
 Engineer's Name PE# Date

Engineer's Signature

SECTION

WATER

DETAIL NO.

WT-9

TITLE

SINGLE 1.5" TO 2" SERVICE

MATERIALS LIST

METER SIZE

A. SERVICE CLAMP FOR CONNECTION- REQUIRED ON ALL _____ (1 1/2") PLASTIC AND ASBESTOS CEMENT PIPE AND ALL IRON PIPE 300 mm (12") AND SMALLER	(2")
B. CORPORATION STOP - SERVICE PIPE OUTLET _____ (1 1/2")	(2")
C. SERVICE PIPE _____ (1 1/2")	(2")
D. COUPLING: SERVICE PIPE TO MALE I.P.T. _____ (1 1/2") (COMPRESSION FITTING)	(2")
E. BALL VALVE. SEE SPL WW 275 _____ (1 1/2")	(2")
F. TEES, BRASS _____ (1 1/2"x1 1/2"x1")	(2"x2"x1")
G. CLOSE-NIPPLE, BRASS _____ (1 1/2")	(2")
H. ANGLE METER STOP, FEMALE I.P. THREAD INLET X _____ (1 1/2") FLANGE OUTLET	(2")
I. WATER METER LENGTH WITH GASKETS _____ (13 1/2")	(17 3/4")
J. FLANGE, BRASS; FEMALE I.P. THREAD _____ (1 1/2")	(2")
K. NIPPLES, BRASS _____ (1 1/2"x8")	(2"x8")
L. BALL VALVE _____ (1 1/2")	(2")
M. NIPPLES, BRASS _____ (1"x5")	(2"x5")
N. 90 DEGREE ELBOWS, BRASS _____ (1 1/2")	(2")
O. NIPPLES, BRASS _____ (1 1/2"x3")	(2"x3")
P. CURB STOP, BRASS, FEMALE I.P. THREAD BOTH ENDS _____ (1 1/2") WITH LOCK NUTS	(2")
Q. COUPLINGS, BRASS, SERVICE PIPE TO MALE THREAD _____ (1 1/2")	(2")
R. SERVICE PIPE _____ (1 1/2")	(2")
S. RECTANGULAR METER BOX. _____ (1 1/2")	(2")
T. METER BOX MSBCF 1730-12, METER BOX LID 32131701 FROM EAST JORDAN IRON WORKS, INC. (SUPPLIER/MANUFACTURER).	
U. RECTANGULAR BOX FOR CUSTOMER'S CUT-OFF VALVE _____ (12"x17"x12") (AND PRV WHEN REQUIRED). DFW #D1200 300 mm X 425 mm X 300 mm (12" X 17" X 12")	(2")
V. CUSTOMER'S BALL VALVE _____ (1 1/2")	(2")

NOTES:

1. DRAWING NOT TO SCALE FOR CLARIFICATION OF DIMENSIONS.
2. ADOPTED FROM CITY OF AUSTIN 520S-13.

SCALE: NOT TO SCALE



MARBLE FALLS
800 THIRD STREET
MARBLE FALLS, TX 78654
PH: (830) 693-6737

These documents were prepared by,
or under the supervision of:

ERIC BELAJ 107148 May 31, 2017
Engineer's Name PE# Date

Engineer's Signature

SECTION

WATER

DETAIL NO.

WT-10

TITLE

SINGLE 1.5" TO 2" SERVICE
MATERIAL LIST

NOTES:

1. SERVICE PIPE SHALL BE 2" SCH. 80 PVC, CLASS 200 OR MUNICIPEX PIPE.
2. SERVICE SADDLES SHALL BE WRAPPED COMPLETELY WITH 8 MIL (0.2mm) POLYETHYLENE FILM.
3. TOP OF METER BOX SHALL BE SET 1 INCH ABOVE FINISHED GRADE.
4. SERVICE PIPE AND CASING PIPE SHALL BE INSTALLED WITH A 6 INCH ENVELOPE OF BEDDING SAND OR 3/8" ROCK AROUND TUBING AND CASING PIPE.
5. ANY VARIATIONS ON FITTINGS MUST BE APPROVED BY THE CITY ENGINEER AND/OR THE CITY OF MARBLE FALLS PUBLIC WORKS DEPARTMENT.
6. AXIS OF METER ASSEMBLY (BALL VALVE, METER, PIPING AND GATE VALVE) SHALL BE 12" BELOW TOP OF BOX.
7. METER BOX SHALL NOT BE MODIFIED.

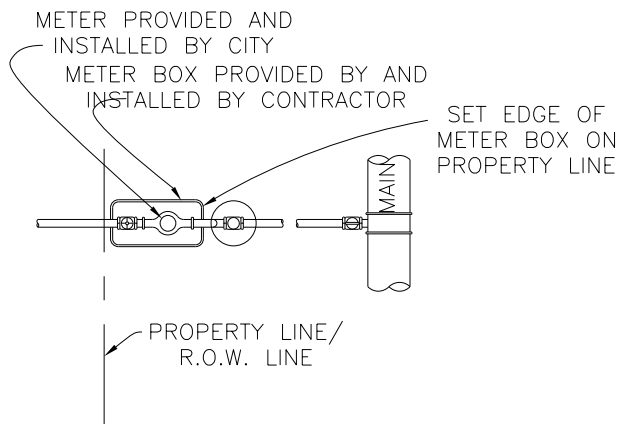

PLAN VIEW

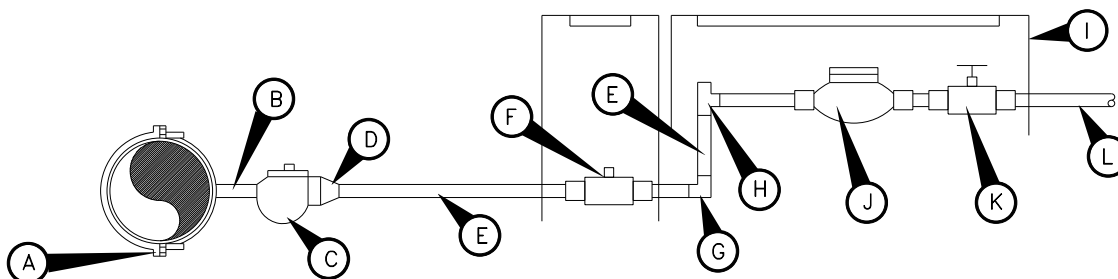

SECTION VIEW

MATERIAL LIST

- A. BRASS TAPPING SADDLE – SERVICE CLAMP REQUIRED – FORD S91 (FOR 2" – 12" C900 PVC ONLY) FOR PVC PIPE SIZES LARGER THAN 12" OR PIPE MATERIALS OTHER THAN PVC, FORD 202B BRASS TAPPING SADDLES SHALL BE USED.
- B. AS SUPPLIED.
- C. 2" CORPORATION STOP – SERVICE PIPE OUTLET – "FORD" FB1102-7.
- D. 2" FEMALE I.P. THREAD TO SERVICE PIPE (COMPRESSION).
- E. 2" SCH. 80 PVC OR MUNICIPEX SERVICE PIPE. WATER SERVICE CASING IS REQUIRED FOR LONG SERVICE LINES CROSSING UNDER ROADWAYS. CASING REQUIRED FOR ALL PAVEMENT CROSSINGS. 4" SDR-26 REQUIRED FOR OPEN-CUT. STEEL CASING PIPE REQUIRED FOR JACK AND BORE. LIMITS OF CASING SHOULD EXTEND SIX FEET BEYOND THE EDGE OF PAVEMENT OR BACK-OF-CURB.
- F. 2" BRASS CURB STOP – "FORD" B77-777, OR APPROVED EQUAL. (BOTH SIDES OF BALL VALVE: SERVICE PIPE TO MALE IP THREAD (COMPRESSION FITTINGS). OUTSIDE METER BOX IN SEPARATE 10" VALVE BOX CAN WITH LID (WESTERN IRON WORKS CASTING NO. 3171000.)
- G. 2" SCH. 80 PVC 90° BEND (SOLVENT WELD)
- H. ANGLE METER VALVE – (FEMALE IP x FLANGE OUTLET) "FORD" FV73-777W OR APPROVED EQUAL.
- I. METER BOX TO BE SOLID BLACK PLASTIC WITH BLACK LID AND FOR METER READING. RHINO MB-16L OR LL MODEL, OR APPROVED EQUAL.

NOTE: J THRU L TO BE INSTALLED UNDER SEPARATE BUILDING PERMIT.

- J. 2" WATER METER – SHALL BE MASTER METER TYPE, FURNISHED BY CITY AND INSTALLED BY CITY (AT OWNER'S EXPENSE).
- K. BRASS GATE VALVE: NON-RISING STEM 2" FEMALE I.P.T. (PROPERTY OWNERS CUT-OFF).
- L. 2" PIPE (SCH. 80 PVC) BY PROPERTY OWNER.

SCALE: NOT TO SCALE



MARBLE FALLS
 800 THIRD STREET
 MARBLE FALLS, TX 78654
 PH: (830) 693-6737

These documents were prepared by,
 or under the supervision of:

ERIC BELAJ 107148 May 31, 2017
 Engineer's Name PE# Date

Engineer's Signature

SECTION

WATER

DETAIL NO.

WT-11

TITLE

SINGLE 2" SERVICE

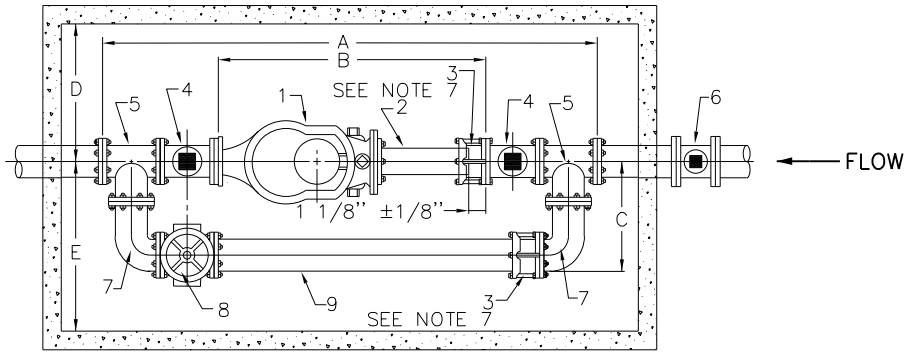

PLAN VIEW

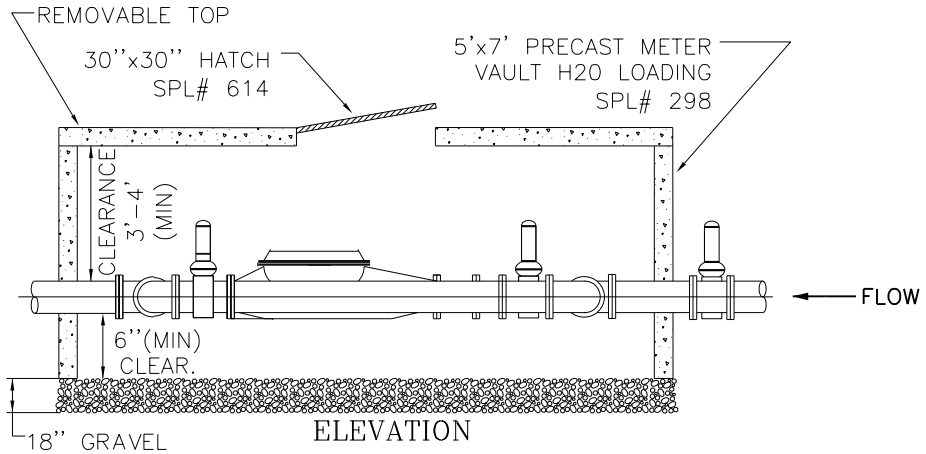

ELEVATION

No.	NAME	Length
A	OVERALL LENGTH	79"
B	METER + NIPPLE + FCA	34 1/2 "
C	CENTER OF MAINLINE TO OUTSIDE OF BYPASS	17 1/2 "
D	CENTERLINE OF MAINLINE TO INSIDE OF VAULT	30"
E	CENTERLINE OF MAINLINE TO INSIDE OF VAULT	30"

NOTE:

- DRAWING NOT TO SCALE FOR CLARIFICATION
- ADOPTED FROM CITY OF AUSTIN 520-15B

SCALE: NOT TO SCALE



MARBLE FALLS
 800 THIRD STREET
 MARBLE FALLS, TX 78654
 PH: (830) 693-6737

These documents were prepared by,
 or under the supervision of:

ERIC BELAJ 107148 May 31, 2017
 Engineer's Name PE# Date

Engineer's Signature

SECTION

WATER

DETAIL NO.

WT-12

TITLE

4" COMPOUND METER
 (1 OF 2)

No.	NAME	Length
1	4" COMPOUND METER	21"*
2	4" FLANGED x PLAIN END	12"
3	4" FLANGED COUPLING ADAPTER	5"
4	COA 4" GATE VALVE SQUARE NUT	9"
5	4" x 4" x 4" FLANGED TEE	13"
6	PROPERTY OWNER'S 4" GATE VALVE SQUARE NUT	9"
7	4" FLANGED LONG RADIUS ELBOW 90°	
8	4" BYPASS GATE VALVE with HANDWHEEL	9"
9	4" BYPASS DUCTILE IRON PIPE	

*DIMENSIONS- SUBJECT TO CHANGE, CHECK WITH INSPECTOR

NOTES:

1. PIPE AND METER SIZE SHALL BE AS DETERMINED BY OWNER, SUBJECT TO APPROVAL BY THE CITY. PLANS MUST BE PREPARED BY LICENSED ENGINEER IF INSTALLATION IN RIGHT-OF-WAY IS BY OTHER THAN CITY FORCES.
2. METER VAULT MUST BE BEHIND CURB AND/OR WALK AND OUT OF VEHICULAR TRAFFIC.
3. MAIN LINE AND BYPASS VALVES WILL BE RESILIENT SEAT TYPE WITH CORROSION RESISTANT FUSION BONDED EPOXY COATING INSIDE AND OUTSIDE, NON-RISING STEM. MAIN LINE VALVES SHALL HAVE SQUARE OPERATING NUTS. BYPASS VALVE WILL HAVE A HANDWHEEL. PROPERTY OWNER'S VALVE MUST BE LOCATED OUTSIDE OF THE CITY'S METER VAULT.
4. APPROVAL WILL BE NEEDED IF HEIGHT OF VAULT EXCEEDS 72".
5. HATCH OPENING WILL BE 30" X 30".
6. IRON PIPE TAPPING SLEEVE IN STREET RIGHT-OF-WAY SHALL BE IMBEDDED IN GRANULAR MATERIALS.
7. DOUBLE HARNESS MJ WITH TIE RODS. ALL OTHER FITTINGS INSIDE VAULT WILL BE FLANGED.
8. CONTACT THE CITY OF MARBLE FALLS CITY ENGINEER PRIOR TO INSTALLATION OF COMPOUND METERS FOR PROPER DOMESTIC DEMANDS.
9. NOTCHES WHERE PIPING GOES THROUGH VAULT SHALL BE FILLED WITH MORTAR.
10. THE TOP OF THE METER VAULT SHALL BE AT AN ELEVATION SUCH THAT THE SURROUNDING GROUND SLOPES AWAY FROM THE VAULT.

NOTE:

1. DRAWING NOT TO SCALE FOR CLARIFICATION
2. ADAPTED FROM CITY OF AUSTIN 520-15B

SCALE: NOT TO SCALE



MARBLE FALLS
800 THIRD STREET
MARBLE FALLS, TX 78654
PH: (830) 693-6737

These documents were prepared by,
or under the supervision of:

ERIC BELAJ 107148 May 31, 2017
Engineer's Name PE# Date

Engineer's Signature

SECTION

WATER

DETAIL NO.

WT-13

TITLE

4" COMPOUND METER
(2 OF 2)

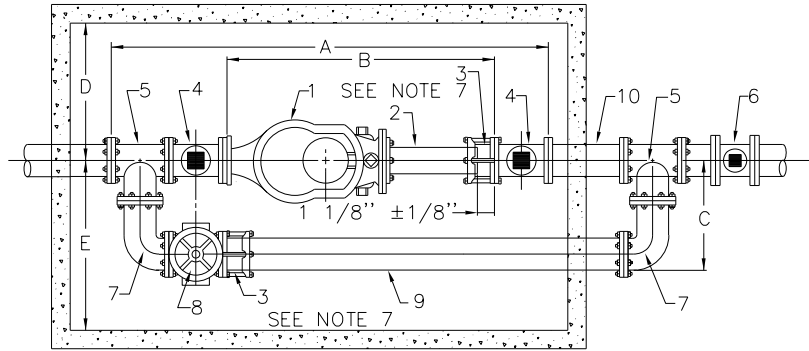

PLAN VIEW

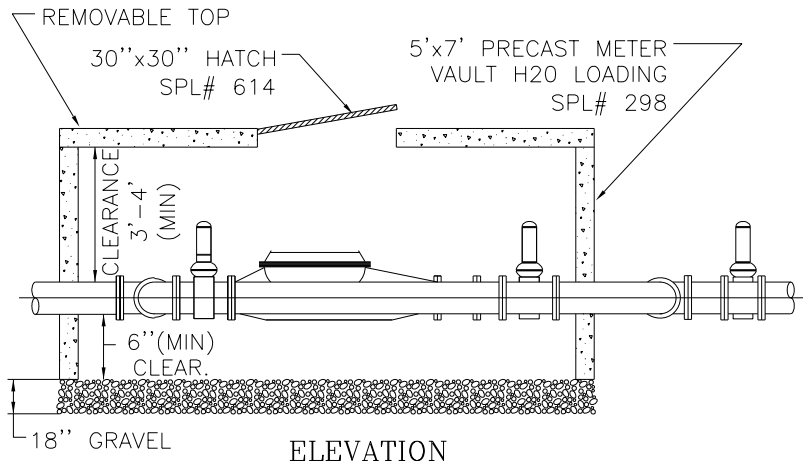

ELEVATION

No.	NAME	Length
A	OVERALL LENGTH	74 3/4''
B	METER + NIPPLE + FCA	37 1/2''
C	CENTER OF MAINLINE TO OUTSIDE OF BYPASS	17 1/2''
D	CENTERLINE OF MAINLINE TO INSIDE OF VAULT	30''
E	CENTERLINE OF MAINLINE TO INSIDE OF VAULT	30''

NOTE:

1. DRAWING NOT TO SCALE FOR CLARIFICATION
2. ADAPTED FROM CITY OF AUSTIN 520-15C

SCALE: NOT TO SCALE



MARBLE FALLS
 800 THIRD STREET
 MARBLE FALLS, TX 78654
 PH: (830) 693-6737

These documents were prepared by,
 or under the supervision of:

ERIC BELAJ 107148 May 31, 2017
 Engineer's Name PE# Date

Engineer's Signature

SECTION

WATER

DETAIL NO.

WT-14

TITLE

6" COMPOUND METER
 (1 OF 2)

No.	NAME	Length
1	6" COMPOUND METER	24"*
2	6" FLANGED x PLAIN END	12"
3	6" FLANGED COUPLING ADAPTER	5"
4	COA 6" GATE VALVE SQUARE NUT	10.5"
5	6" x 6" x 6" FLANGED TEE	16"
6	PROPERTY OWNER'S 6" GATE VALVE SQUARE NUT	10.5"
7	6" FLANGED ELBOW 90°	
8	6" BYPASS GATE VALVE with HANDWHEEL	10.5"
9	6" BYPASS DUCTILE IRON PIPE	
10	6" FLANGED SPOOL	

*DIMENSIONS- SUBJECT TO CHANGE, CHECK WITH INSPECTOR

NOTES:

1. PIPE AND METER SIZE SHALL BE AS DETERMINED BY OWNER, SUBJECT TO APPROVAL BY THE CITY. PLANS MUST BE PREPARED BY LICENSED ENGINEER IF INSTALLATION IN RIGHT-OF-WAY IS BY OTHER THAN CITY FORCES.
2. METER VAULT MUST BE BEHIND CURB AND/OR WALK AND OUT OF VEHICULAR TRAFFIC.
3. MAIN LINE AND BYPASS VALVES WILL BE RESILIENT SEAT TYPE WITH CORROSION RESISTANT FUSION BONDED EPOXY COATING INSIDE AND OUTSIDE, NON-RISING STEM. MAIN LINE VALVES SHALL HAVE SQUARE OPERATING NUTS. BYPASS VALVE WILL HAVE A HANDWHEEL. PROPERTY OWNER'S VALVE MUST BE LOCATED OUTSIDE OF THE CITY'S METER VAULT.
4. APPROVAL WILL BE NEEDED IF HEIGHT OF VAULT EXCEEDS 72".
5. HATCH OPENING WILL BE 30" X 30".
6. IRON PIPE TAPPING SLEEVE IN STREET RIGHT-OF-WAY SHALL BE IMBEDDED IN GRANULAR MATERIALS.
7. DOUBLE HARNESS MJ WITH TIE RODS. ALL OTHER FITTINGS INSIDE VAULT WILL BE FLANGED.
8. CONTACT THE CITY OF MARBLE FALLS CITY ENGINEER PRIOR TO INSTALLATION OF COMPOUND METERS FOR PROPER DOMESTIC DEMANDS.
9. NOTCHES WHERE PIPING GOES THROUGH VAULT SHALL BE FILLED WITH MORTAR.
10. THE TOP OF THE METER VAULT SHALL BE AT AN ELEVATION SUCH THAT THE SURROUNDING GROUND SLOPES AWAY FROM THE VAULT.

NOTE:

1. DRAWING NOT TO SCALE FOR CLARIFICATION
2. ADAPTED FROM CITY OF AUSTIN 520-15C

SCALE: NOT TO SCALE



MARBLE FALLS
800 THIRD STREET
MARBLE FALLS, TX 78654
PH: (830) 693-6737

These documents were prepared by,
or under the supervision of:

ERIC BELAJ 107148 May 31, 2017
Engineer's Name PE# Date

Engineer's Signature

SECTION

WATER

DETAIL NO.

WT-15

TITLE

6" COMPOUND METER
(2 OF 2)

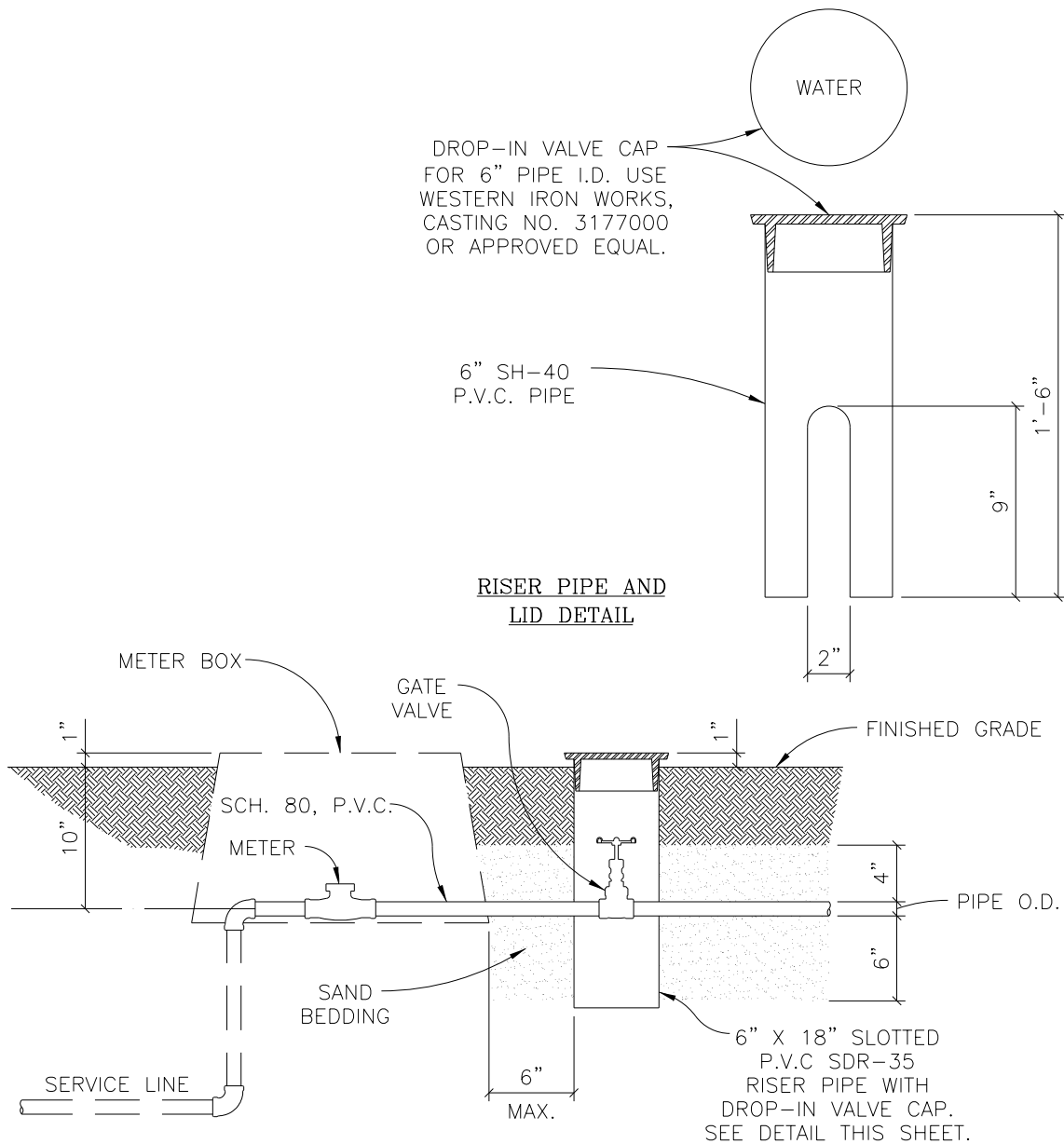

NOTES:

1. GATE VALVE SHALL BE A HAMMOND IB645, CLASS 125, BRONZE GATE, SCREWED BONNET, NON-RISING STEM, SOLID WEDGE DISC WITH THREADED ENDS OR APPROVED EQUAL.
2. DROP-IN VALVE CAP SHALL BE CAST WITH THE WORD "WATER" ON TOP.
3. USE SCHEDULE 80, M.I.P. ADAPTER AS REQUIRED.

SCALE: NOT TO SCALE



MARBLE FALLS
 800 THIRD STREET
 MARBLE FALLS, TX 78654
 PH: (830) 693-6737

These documents were prepared by,
 or under the supervision of:

ERIC BELAJ 107148 May 31, 2017
 Engineer's Name PE# Date

Engineer's Signature

SECTION

WATER

DETAIL NO.

WT-16

TITLE

SERVICE CUT-OFF SECTION

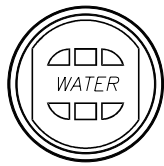

SEWER VALVE LID

"WATER" TO BE CAST IN COVER WHEN USED ON WATER MAIN OR "SEWER" WHEN USED ON FORCE MAIN

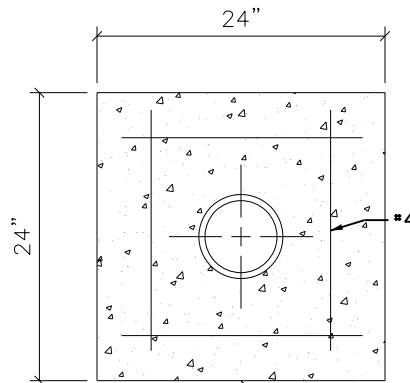

CONCRETE COLLAR
6" THICK MINIMUM

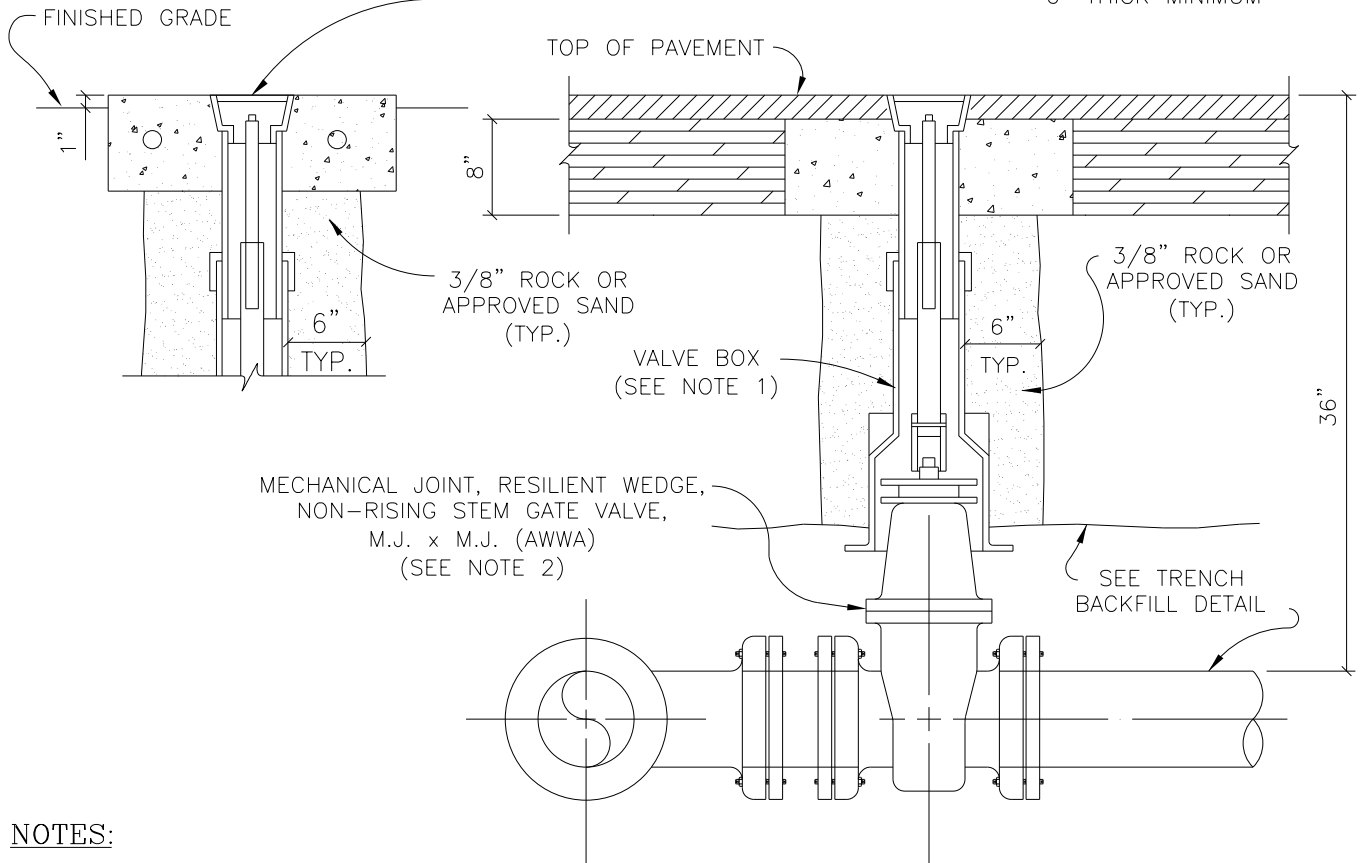

NOTES:

1. VALVE BOX SHALL BE DOMESTIC EAST JORDAN IRON WORKS OR APPROVED EQUAL HAVING AN ADJUSTABLE RANGE OF + OR - 6 INCHES FROM INSTALLED FINISH GRADE.
2. ACCEPTABLE GATE VALVES ARE:
 - A. N/A
 - B. MUELLER - 2360 SERIES
 - C. CLOW

SCALE: NOT TO SCALE



MARBLE FALLS
800 THIRD STREET
MARBLE FALLS, TX 78654
PH: (830) 693-6737

These documents were prepared by,
or under the supervision of:

ERIC BELAJ 107148 May 31, 2017
Engineer's Name PE# Date

Engineer's Signature

SECTION

WATER

DETAIL NO.

WT-17

TITLE

WATER VALVE



SEWER VALVE LID

"WATER" TO BE CAST IN COVER WHEN USED ON WATER MAIN OR "SEWER" WHEN USED ON FORCE MAIN

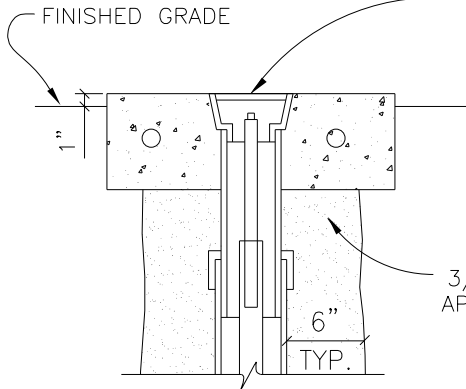

"SEWER" TO BE CAST IN COVER WHEN USED ON FORCE MAIN

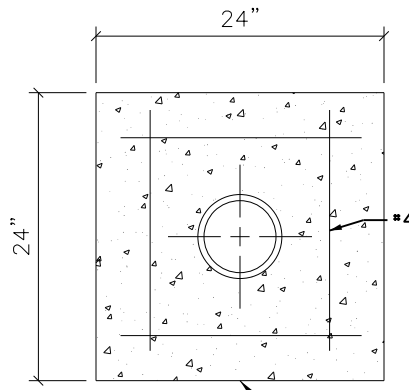
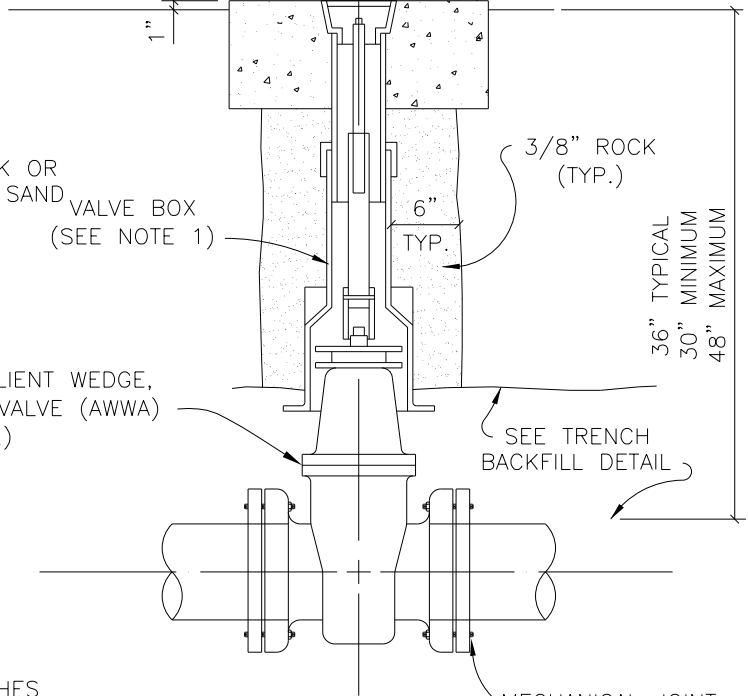

CONCRETE COLLAR
6" THICK MINIMUM

MECHANICAL JOINT, RESILIENT WEDGE,
NON-RISING STEM GATE VALVE (AWWA)
(SEE NOTE 2)

MECHANICAL JOINT
WITH RETAINER GLAND AND
LOCKING SET SCREWS

NOTES:

1. VALVE BOX SHALL BE EAST JORDAN IRON WORKS OR APPROVED EQUAL HAVING AN ADJUSTABLE RANGE OF + OR - 6 INCHES FROM INSTALLED FINISH GRADE. (SEE TYPICAL SEWER VALVE SETTING)
2. ACCEPTABLE GATE VALVES ARE:
 - A. N/A
 - B. MUELLER - 2360 SERIES
 - C. CLOW

SCALE: NOT TO SCALE



MARBLE FALLS
800 THIRD STREET
MARBLE FALLS, TX 78654
PH: (830) 693-6737

These documents were prepared by,
or under the supervision of:

ERIC BELAJ 107148 May 31, 2017
Engineer's Name PE# Date

Engineer's Signature

SECTION

WATER

DETAIL NO.

WT-18

TITLE

IN-LINE VALVE

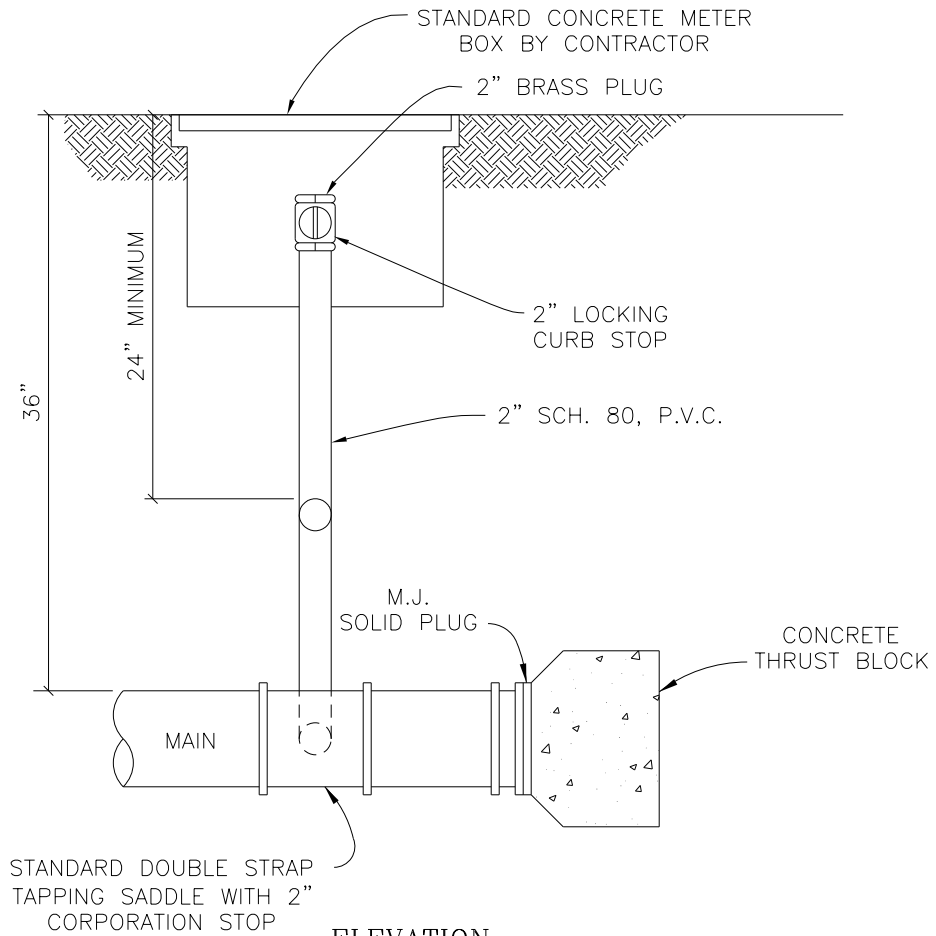

ELEVATION

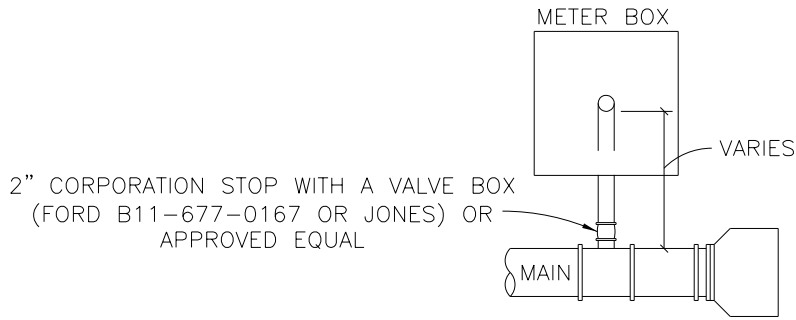

PLAN

NOTES:

1. TRAFFIC BEARING METER BOXES WILL BE REQUIRED IN ALL PAVED AREAS AND AREAS WHICH MAY BE PAVED IN THE FUTURE.
2. TUBING SHALL BE CONTINUOUS FROM CORPORATION STOP TO CURB STOP, NO FITTINGS SHALL BE PERMITTED.

SCALE: NOT TO SCALE



MARBLE FALLS
800 THIRD STREET
MARBLE FALLS, TX 78654
PH: (830) 693-6737

These documents were prepared by,
or under the supervision of:

ERIC BELAJ 107148 May 31, 2017
Engineer's Name PE# Date

[Signature]
Engineer's Signature

SECTION

WATER

DETAIL NO.

WT-19

TITLE

BLOW-OFF CONNECTION

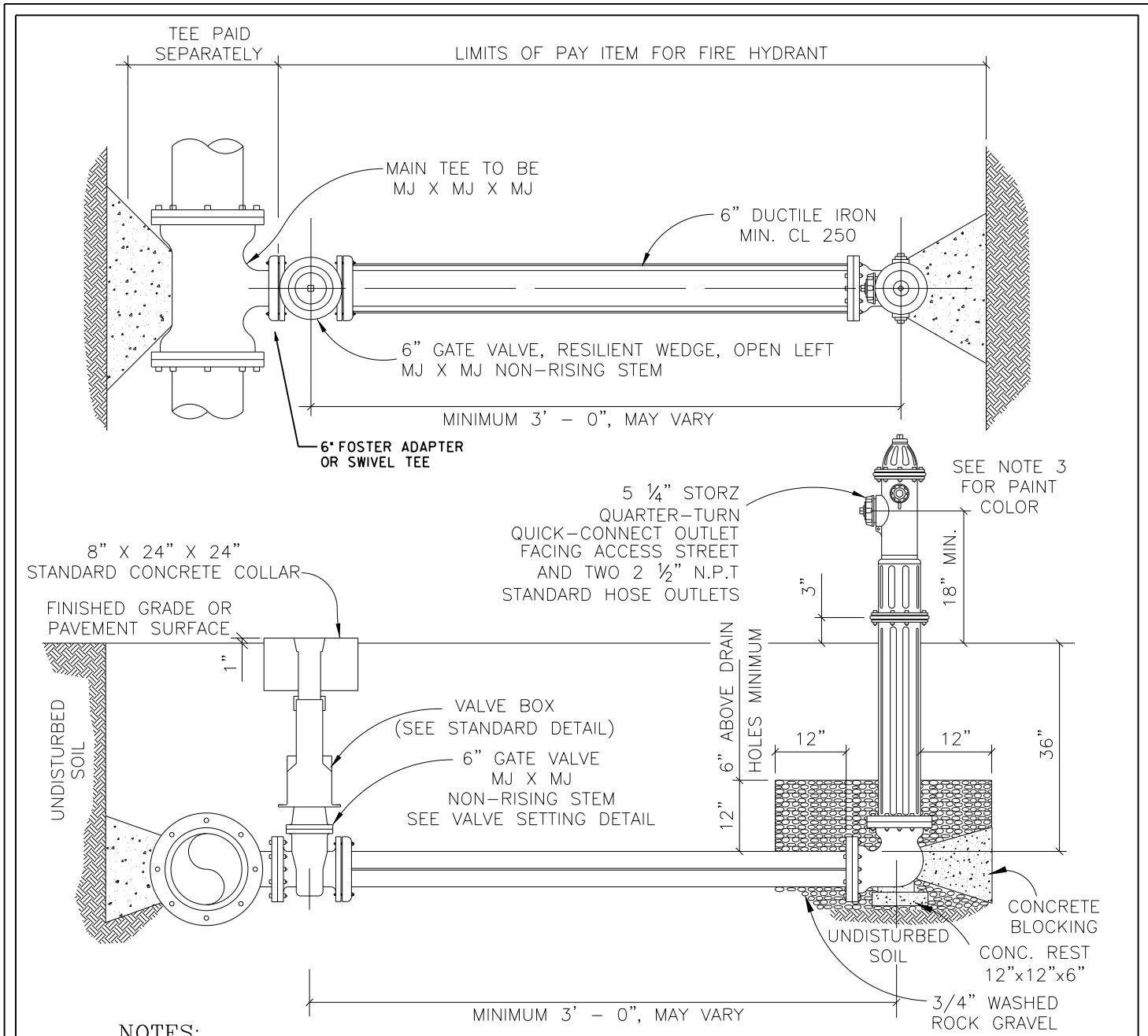

NOTES:

1. FIRE HYDRANT SHALL BE INSTALLED ON SAME SIDE OF ROAD AS WATER MAIN.
2. FIRE HYDRANT SHALL BE INSTALLED PLUMB AND TRUE.
3. ALL FIRE HYDRANT EXTERIORS SHALL BE FACTORY PRIMED AND PAINTED MARBLE FALLS STANDARD COLOR. USING A HIGH GRADE ENAMEL.
4. HEEL AND THRUST BLOCKS TO REST IN UNDISTURBED SOIL.
5. ACCEPTABLE FIRE HYDRANTS ARE:
 - A. MUELLER CENTURION
 - B. AMERICAN DARLING
 - C. CLOW MEDALLION
6. DOUBLE BLUE REFLECTOR "HYE-LITES" BRAND, MANUFACTURED BY PAVEMENT MARKERS INC. TO BE INSTALLED AT CENTERLINE OF STREET PERPENDICULAR TO HYDRANT.

SCALE: NOT TO SCALE



MARBLE FALLS
 800 THIRD STREET
 MARBLE FALLS, TX 78654
 PH: (830) 693-6737

These documents were prepared by,
 or under the supervision of:

ERIC BELAJ 107148 May 31, 2017
 Engineer's Name PE# Date

[Signature]
 Engineer's Signature

SECTION

WATER

DETAIL NO.

WT-20

TITLE

STANDARD FIRE HYDRANT
 ASSEMBLY (1 OF 2)

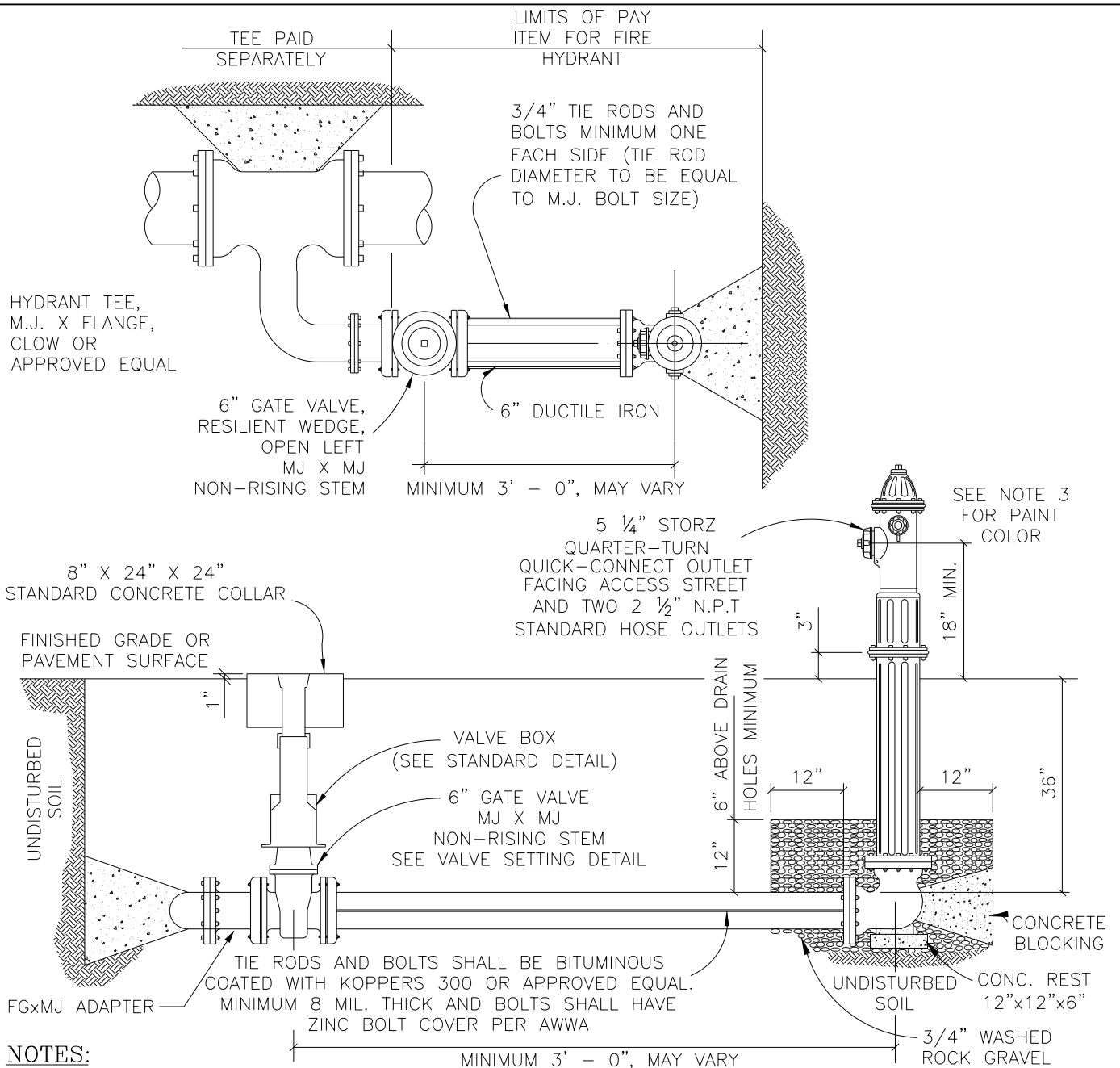

NOTES:

1. FIRE HYDRANT SHALL BE INSTALLED ON SAME SIDE OF ROAD AS WATER MAIN.
2. FIRE HYDRANT SHALL BE INSTALLED PLUMB AND TRUE.
3. ALL FIRE HYDRANT EXTERIORS SHALL BE FACTORY PRIMED AND PAINTED MARBLE FALLS STANDARD COLOR. USING A HIGH GRADE ENAMEL.
4. HEEL AND THRUST BLOCKS TO REST IN UNDISTURBED SOIL.
5. ACCEPTABLE FIRE HYDRANTS ARE:
 - A. MUELLER CENTURION
 - B. AMERICAN DARLING
 - C. CLOW MEDALLION
6. DOUBLE BLUE REFLECTOR "HYE-LITES" BRAND, MANUFACTURED BY PAVEMENT MARKERS INC. TO BE INSTALLED AT CENTERLINE OF STREET PERPENDICULAR TO HYDRANT.

SCALE: NOT TO SCALE



MARBLE FALLS
 800 THIRD STREET
 MARBLE FALLS, TX 78654
 PH: (830) 693-6737

These documents were prepared by,
 or under the supervision of:

ERIC BELAJ 107148 May 31, 2017
 Engineer's Name PE# Date

 Engineer's Signature

SECTION

WATER

DETAIL NO.

WT-21

TITLE

PARALLEL FIRE HYDRANT
 ASSEMBLY (2 OF 2)

CONCRETE COLLAR (MIN. 3,000 PSI) WITH 6x6x#6 WELDED WIRE MESH OVER BACKFILL COMPACTED TO 95% DENSITY WITH TEST REPORTS PROVIDED TO THE CITY. SEE NOTE 1

NOTE:

PLAN VIEW SHOWN ONLY FOR CLARIFICATION OF SECTION "X-X" AND "Y-Y".

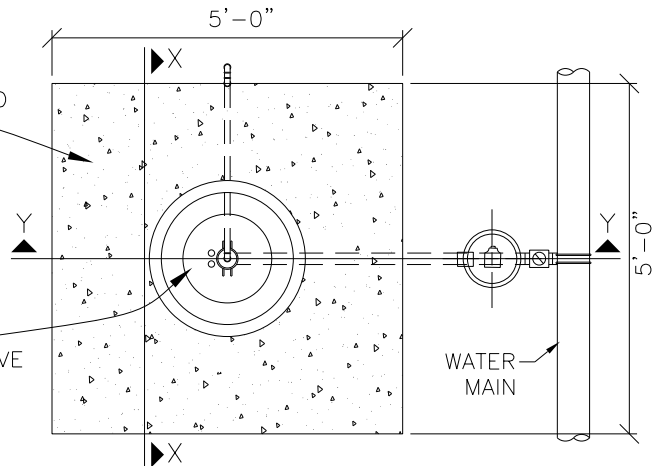

PLAN

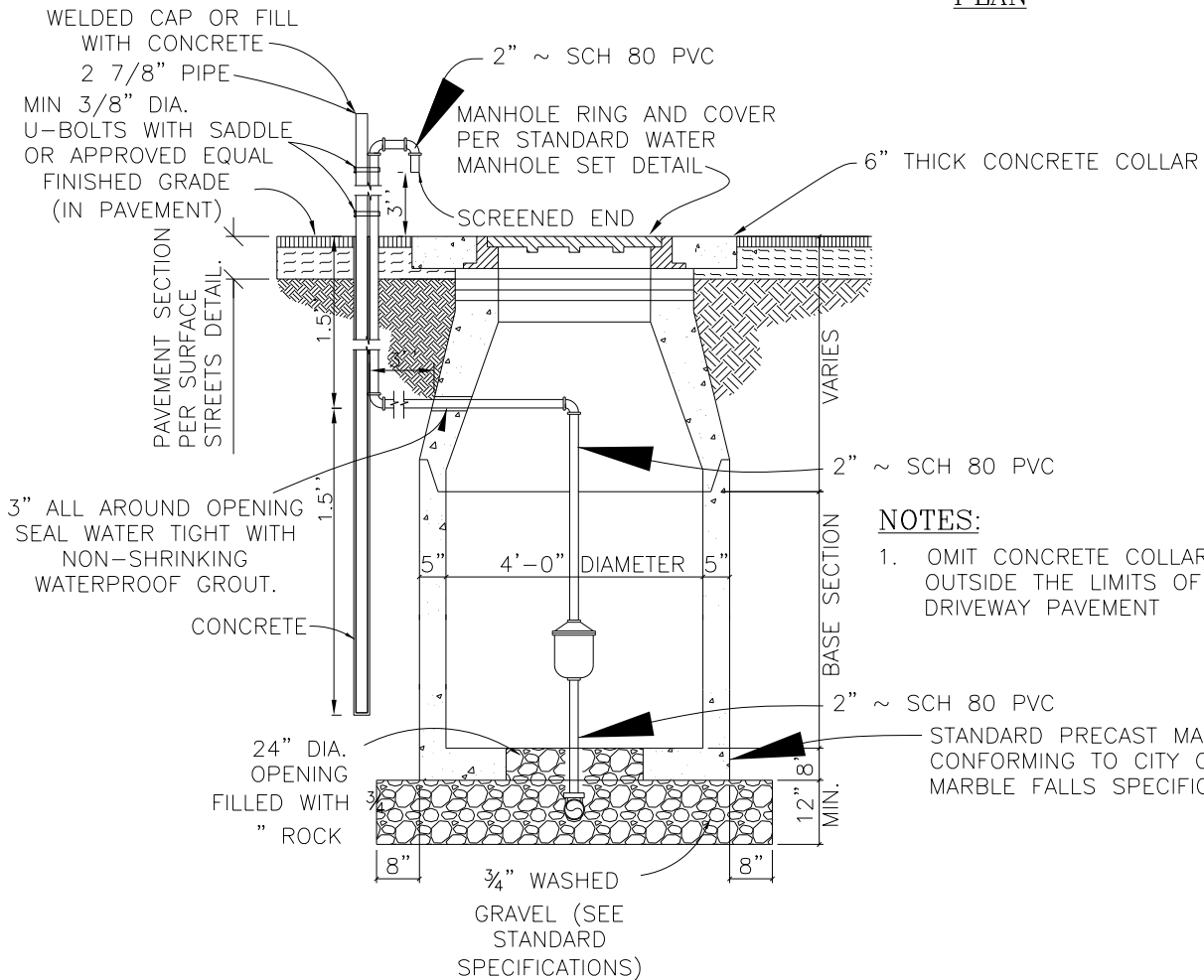

SECTION "X-X"

NOTES:

1. OMIT CONCRETE COLLAR IN AREAS OUTSIDE THE LIMITS OF ROADWAY OR DRIVEWAY PAVEMENT

SCALE: NOT TO SCALE



MARBLE FALLS
 800 THIRD STREET
 MARBLE FALLS, TX 78654
 PH: (830) 693-6737

These documents were prepared by,
 or under the supervision of:

ERIC BELAJ 107148 May 31, 2017
 Engineer's Name PE# Date

[Signature]
 Engineer's Signature

SECTION

WATER

DETAIL NO.

WT-22

TITLE

AIR RELEASE-VACUUM VALVE (1 OF 2)

CONCRETE COLLAR (MIN. 3,000 PSI) WITH 6x6x#6 WELDED WIRE MESH OVER BACKFILL COMPACTED TO 95% DENSITY WITH TEST REPORTS PROVIDED TO THE CITY. SEE NOTE 1

NOTE:

PLAN VIEW SHOWN ONLY FOR CLARIFICATION OF SECTION "X-X" AND "Y-Y".

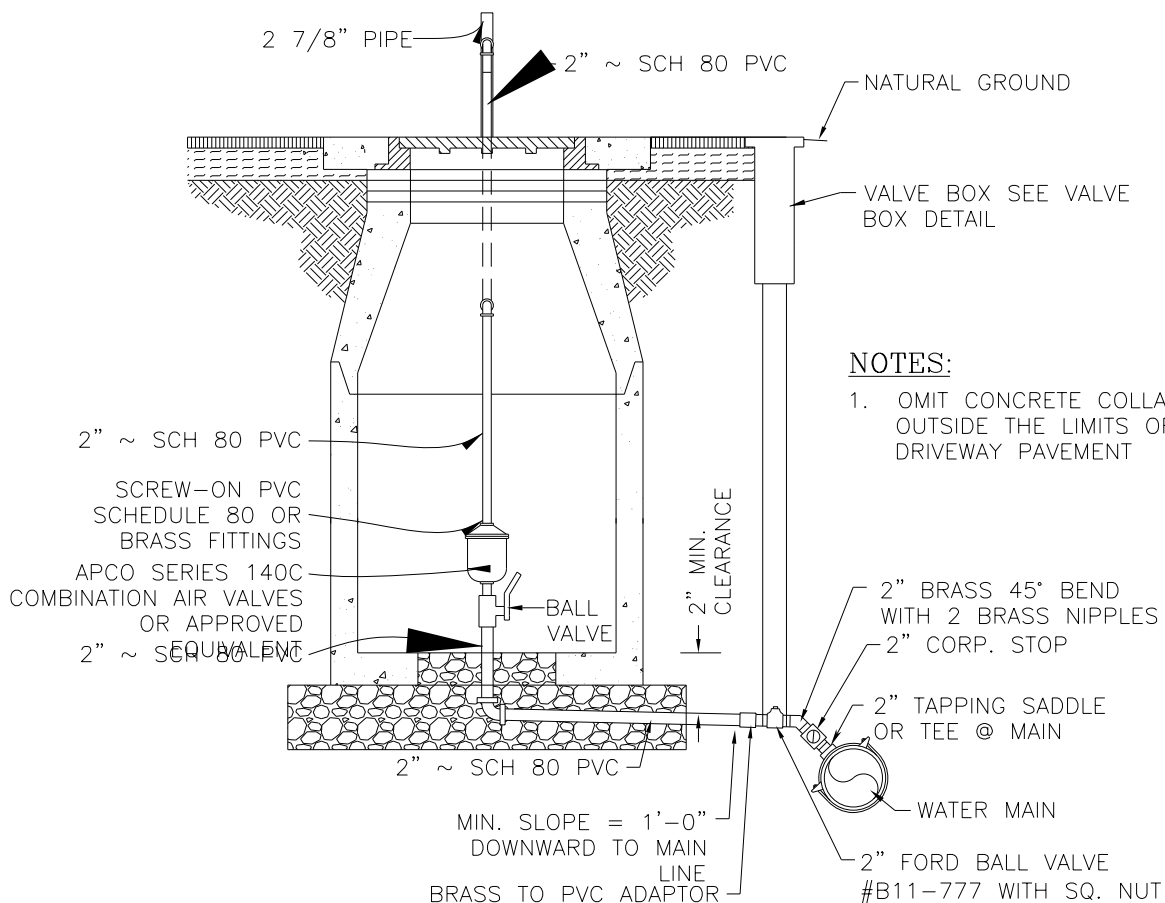
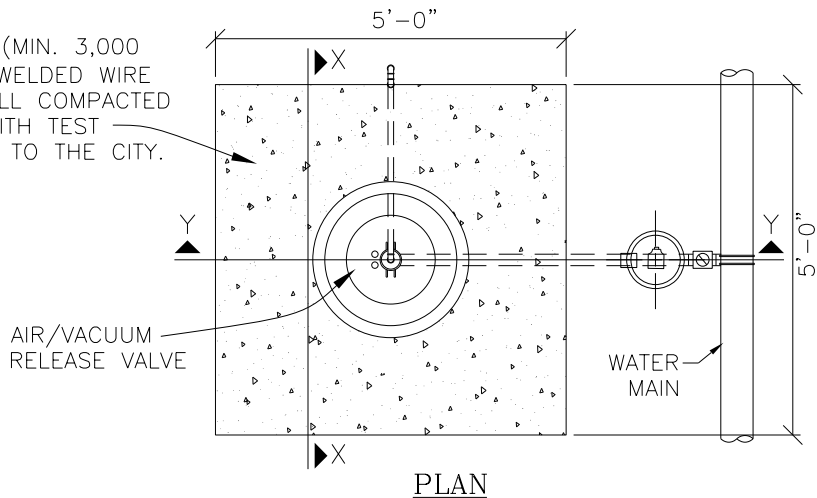

NOTES:

1. OMIT CONCRETE COLLAR IN AREAS OUTSIDE THE LIMITS OF ROADWAY OR DRIVEWAY PAVEMENT

SECTION "Y-Y"

SCALE: NOT TO SCALE



MARBLE FALLS
 800 THIRD STREET
 MARBLE FALLS, TX 78654
 PH: (830) 693-6737

These documents were prepared by,
 or under the supervision of:

ERIC BELAJ	107148	May 31, 2017
Engineer's Name	PE#	Date

[Signature]
 Engineer's Signature

SECTION	WATER
DETAIL NO.	WT-23
TITLE	AIR RELEASE-VACUUM VALVE (2 OF 2)

- 1-DIAMETERx6" TANGENTIAL OUTLET TEE - MJxMJxFLG.
- 1-6" M.J. X FLANGE GATE VALVE
- 1-6" M.J. 45° BEND
- 1-6" M.J. CAP 1-VALVE BOX

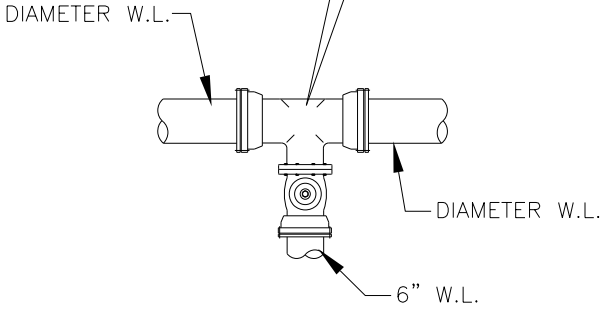

PLAN VIEW

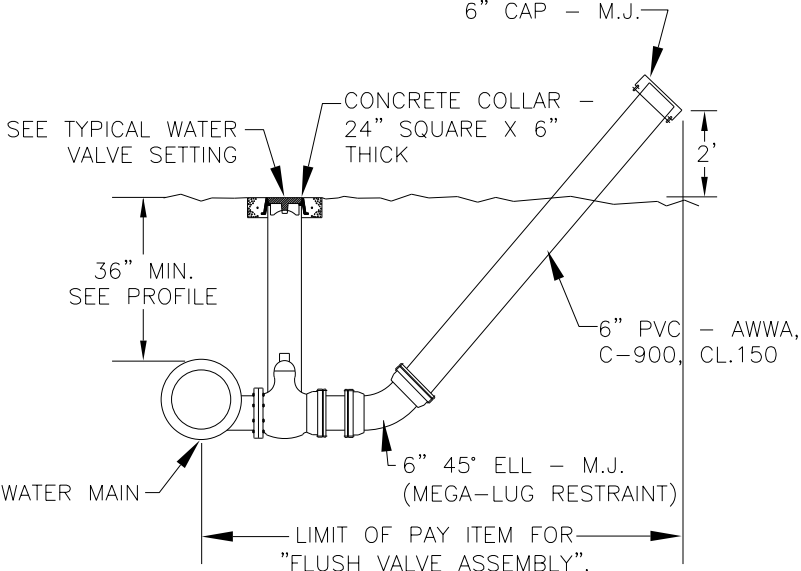

ELEVATION

SCALE: NOT TO SCALE



MARBLE FALLS
 800 THIRD STREET
 MARBLE FALLS, TX 78654
 PH: (830) 693-6737

These documents were prepared by,
 or under the supervision of:

ERIC BELAJ 107148 May 31, 2017
 Engineer's Name PE# Date



Engineer's Signature

SECTION
WATER

DETAIL NO.
WT-24

TITLE
 FLUSH CONNECTION

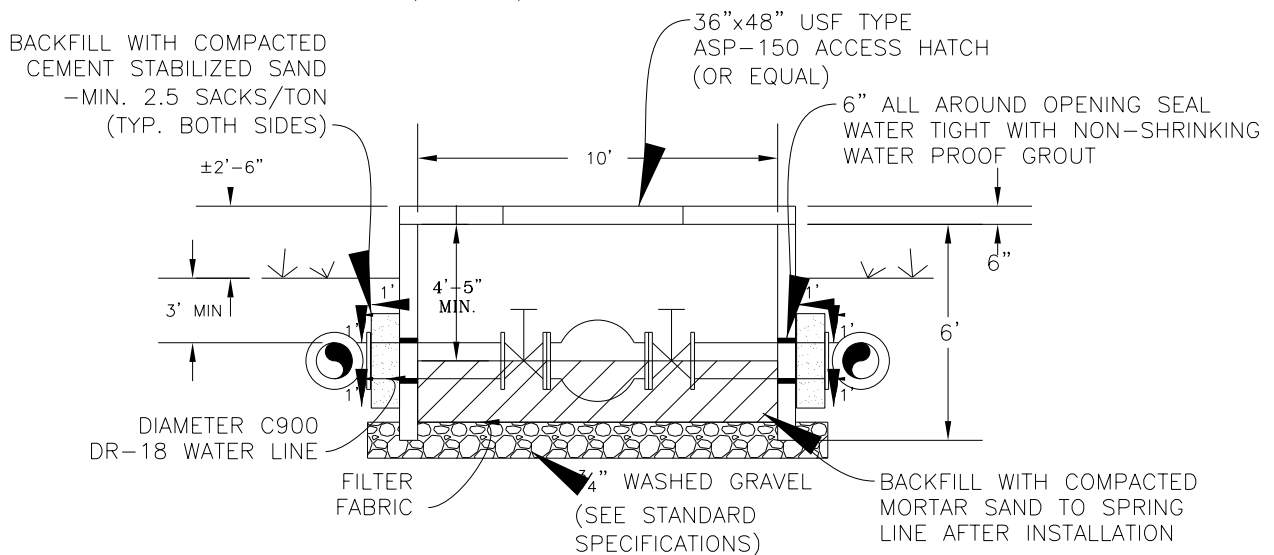
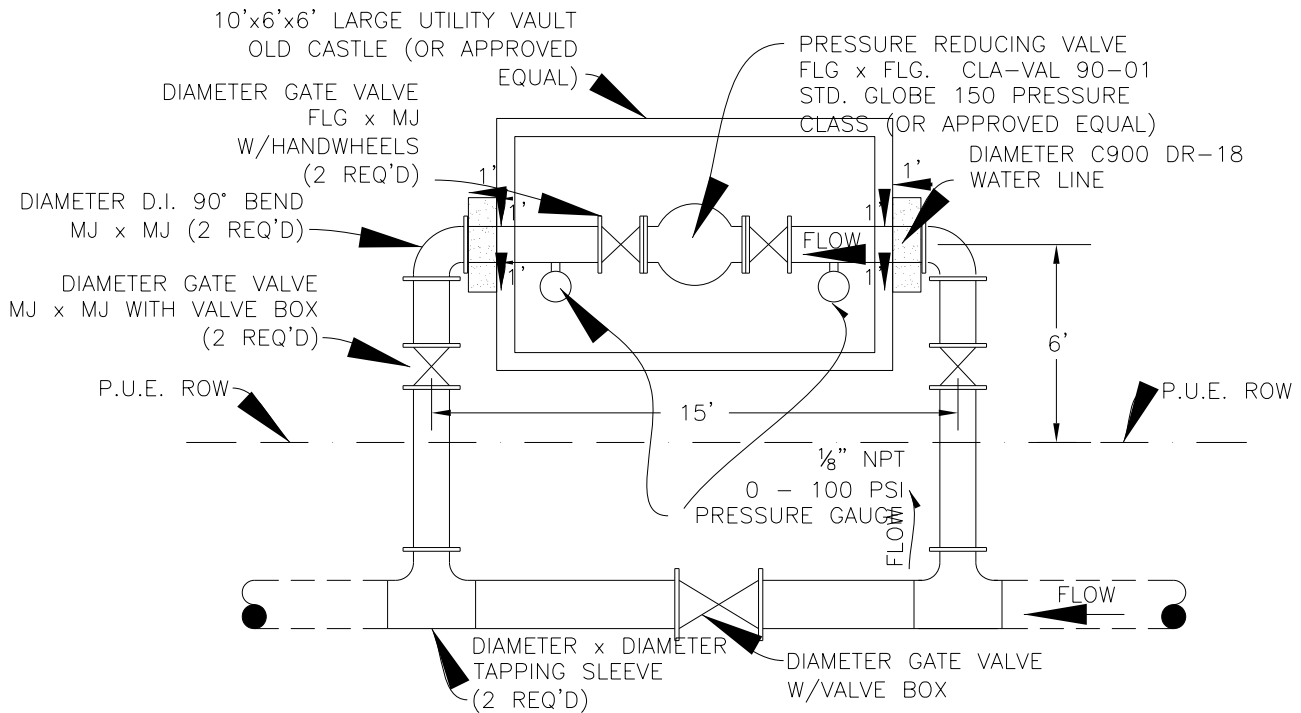

SET POINTS: VALVE SETTINGS SHALL BE DETERMINED BY DESIGN ENGINEER.

NOTE:

1. INSTALL VALVE AS SHOWN WITH WEIGHT OF VALVE FULLY SUPPORTED ON COMPACTED MORTAR SAND BEFORE ADDING WATER TIGHT GROUT OR CEMENT STABILIZED SAND.
2. INSTALL GAUGES TO BE VISIBLE FROM VAULT OPENING.
3. ALL MJ FITTINGS TO INCORPORATE "MEGALUG" RETRAINING GLANDS.

SCALE: NOT TO SCALE



MARBLE FALLS
800 THIRD STREET
MARBLE FALLS, TX 78654
PH: (830) 693-6737

These documents were prepared by,
or under the supervision of:

ERIC BELAJ 107148 May 31, 2017
Engineer's Name PE# Date

Engineer's Signature

SECTION

WATER

DETAIL NO.

WT-25

TITLE

PRESSURE REDUCING VALVE

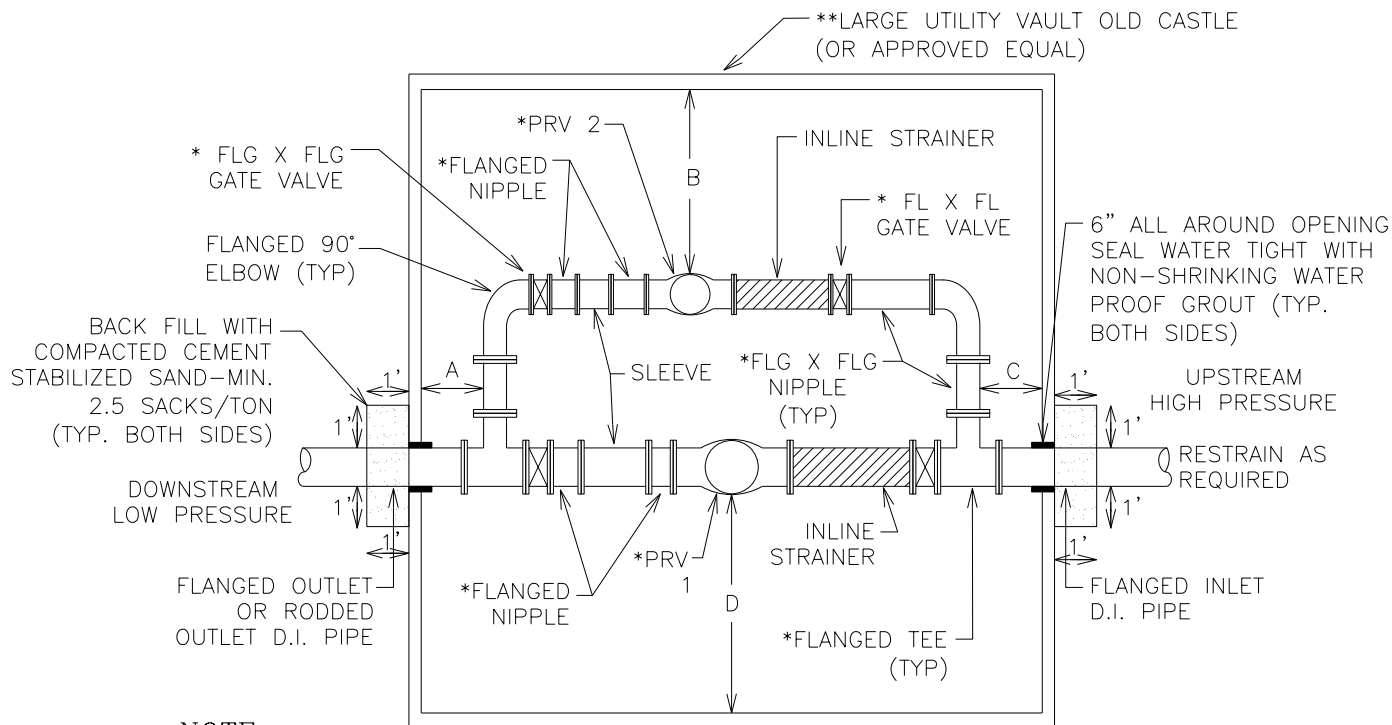

NOTE:

**ACTUAL SIZE OF BOX WILL BE DESIGNED BY ENGINEER BASED ON PRV SIZE.

* SIZE AND TYPE TO BE DETERMINED BY DESIGN ENGINEER.

ELEVATION

NOTES:

1. GATE VALVES TO BE WHEEL OPERATED.
2. ALL SLEEVES TO BE ON DOWNSTREAM SIDE FOR SAFETY PURPOSES.
3. ALL UPSTREAM OR HIGH PRESSURE MATERIALS TO BE FLANGED.
4. ALL NON-FLANGED PIPE TO BE INSTALLED WITH MEG-A-LUG RETAINER GLAND OR APPROVED EQUIVALENT RETAINER.
5. ALL VALVES TO HAVE CONCRETE SUPPORT BLOCKS.
6. ALL POINTS "A" THROUGH "D" TO A MIN. 18" CLEARANCE.
7. ALL PIPE IN PRV/BY-PASS INSTALLATION TO BE THREADED BRASS OR FLANGED D.I. OR C.I. PIPE.
8. PRESSURE REDUCER VALVE SHALL BE PRE APPROVED BY THE CITY OF MARBLE FALLS.
9. THE DESIGN ENGINEER SHALL PROVIDE THE ALTITUDE AND THE PRESSURE ON THE LOW SIDE OF THE PRV ON THE PLANS.
10. PRV WILL NOT BE INSTALLED IN TRAFFIC AREAS.
11. WEIGHT OF VALVE SHALL BE FULLY SUPPORTED ON COMPACTED MORTOR SAND BEFORE ADDING WATER TIGHT GROUT OR CEMENT STABILIZED SAND.

SCALE: NOT TO SCALE



MARBLE FALLS
800 THIRD STREET
MARBLE FALLS, TX 78654
PH: (830) 693-6737

These documents were prepared by,
or under the supervision of:

ERIC BELAJ 107148 May 31, 2017
Engineer's Name PE# Date

Engineer's Signature

SECTION

WATER

DETAIL NO.

WT-26

TITLE

DUAL PRESSURE
REDUCING VALVE

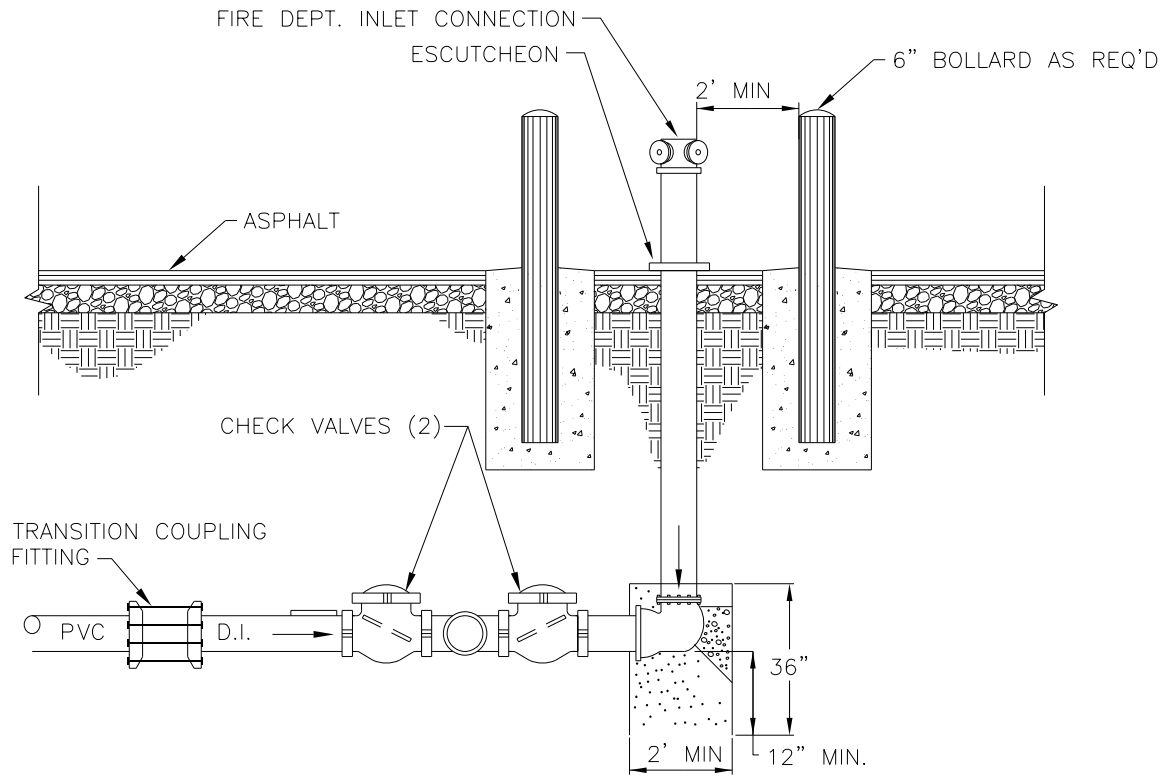

SECTION VIEW

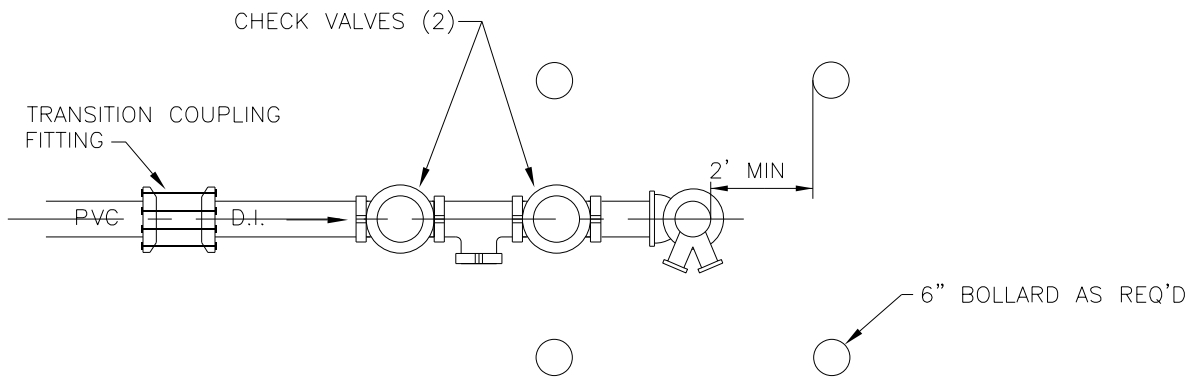

PLAN VIEW

SCALE: NOT TO SCALE



MARBLE FALLS
 800 THIRD STREET
 MARBLE FALLS, TX 78654
 PH: (830) 693-6737

These documents were prepared by,
 or under the supervision of:

ERIC BELAJ 107148 May 31, 2017
 Engineer's Name PE# Date

[Handwritten Signature]
 Engineer's Signature

SECTION

WATER

DETAIL NO.

WT-28

TITLE

FIRE DEPARTMENT
 CONNECTION

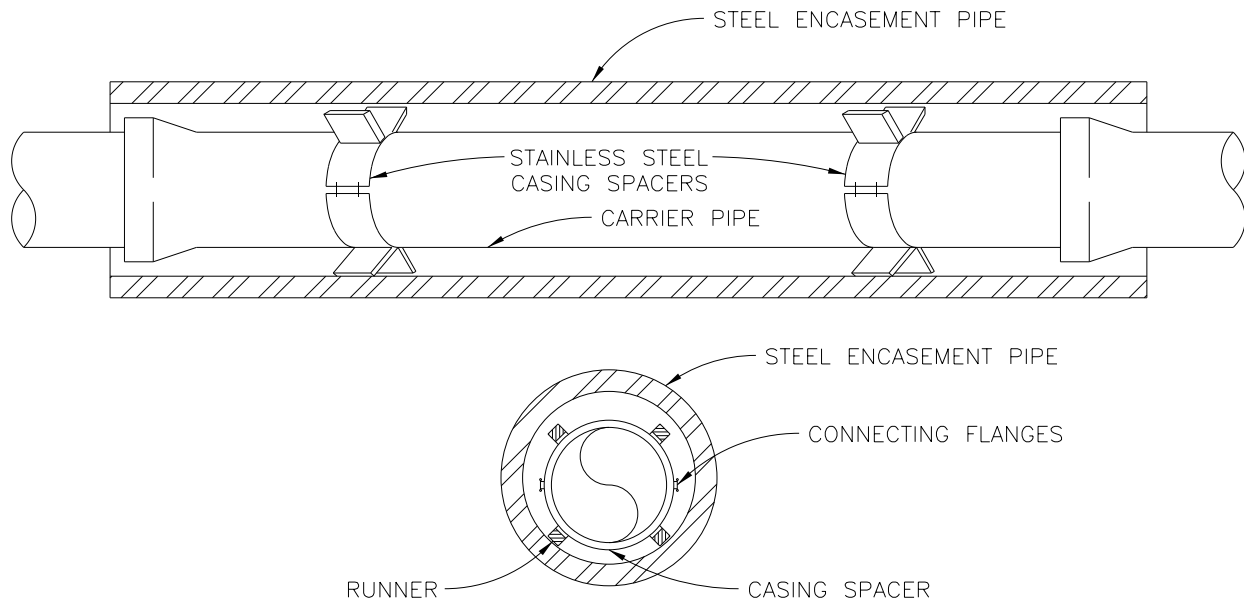

NOTES:

1. CASING SPACERS SHALL BE BOLT ON STYLE WITH A SHELL MADE IN TWO SECTIONS OF HEAVY T-304 STAINLESS STEEL. CONNECTING FLANGES SHALL BE RIBBED FOR EXTRA STRENGTH.
2. CASING SPACERS SHALL BE MADE BY CASCADE WATERWORKS MFG. CO. OR APPROVED EQUAL. CASING SPACERS SHALL HAVE RUNNERS MADE OF ULTRA HIGH MOLECULAR WEIGHT POLYMER, WITH A MINIMUM HEIGHT OF 2 INCHES.
3. DO NOT USE WEDGES BETWEEN TOP OF CARRIER PIPE AND INSIDE OF CASING TO KEEP PIPE FROM MOVING.
4. PRIOR TO INSERTING CARRIER PIPE, ANY WATER SHOULD BE PUMPED OUT OF THE CASING PIPE SO THAT NO MORE THAN A FEW INCHES OF WATER REMAINS.
5. SPACERS WILL BE REQUIRED WITHIN AT LEAST 3 FEET FROM BOTH OPENINGS OF THE ENCASEMENT PIPE AND SPACED NO GREATER THAN 6 FEET THROUGHOUT THE ENCASEMENT PIPE. IN ADDITION, SPACERS SHALL BE REQUIRED WITHIN 2 FEET OF ALL PIPE JOINTS.
6. ENCASEMENT PIPE SHALL BE SMOOTH STEEL 35,000 PSI YIELD STRENGTH WITH THICKNESS ACCORDING TO THE FOLLOWING TABLE:

PIPE SIZE-CARRIER (DIAMETER)	PIPE SIZE-CASING (DIAMETER)(MIN.)	MINIMUM PIPE THICKNESS (INCHES)	
6"	16"	1/4	0.2500
8"	18"	1/4	0.2500
10"	20"	5/16	0.3125
12" - 14"	24"	3/8	0.3750
16" - 18"	30"	7/16	0.4375
20"	36"	1/2	0.5000
24"	42"	1/2	0.5000
30"	48"	1/2	0.5000

SCALE: NOT TO SCALE



MARBLE FALLS
800 THIRD STREET
MARBLE FALLS, TX 78654
PH: (830) 693-6737

These documents were prepared by,
or under the supervision of:

ERIC BELAJ 107148 May 31, 2017
Engineer's Name PE# Date

[Signature]
Engineer's Signature

SECTION

WATER

DETAIL NO.

WT-29

TITLE

PIPE CASING

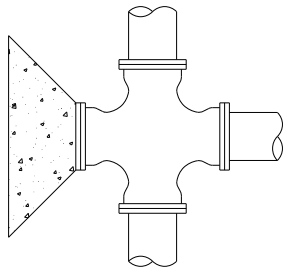

CROSS WITH PLUG

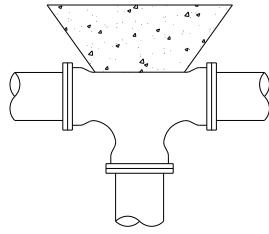

TEE

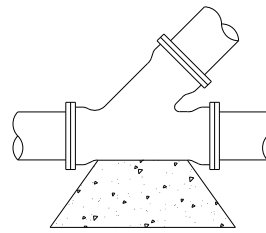

WYE

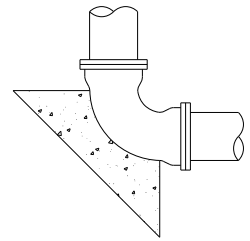

BEND

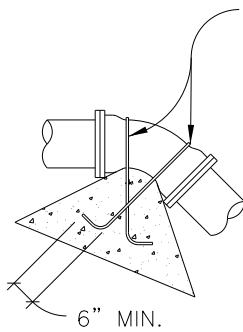

*DEADMAN

#5 REBAR MIN. 2 REQUIRED
BEND TO FIT AND PAINT
WITH 2 COATS BITUMINISTIC
PAINT BEFORE ASSEMBLY.

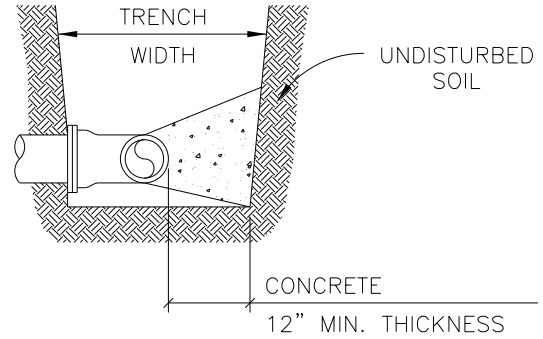

TYPICAL SECTION

ALL THRUST BLOCKS SHALL BE FORMED. LAID FORMS SHALL BE INSPECTED BY THE CITY OF MARBLE FALLS PRIOR TO THE POURING OF CONCRETE AND SHALL ALSO BE INSPECTED BY THE CITY OF MARBLE FALLS PRIOR TO COVERING. TYPICAL LOCATIONS WHICH REQUIRE CONCRETE REACTION (THRUST) BLOCKS, FOR PRESSURE MAINS FOUR INCHES (4") AND GREATER. CONCRETE SHALL HAVE 2500 P.S.I. MINIMUM STRENGTH AT TWENTY EIGHT (28) DAYS AND BEAR AGAINST UNDISTURBED STABLE SOILS, AREA OF CONTACT SHALL BE GOVERNED BY PIPE SIZE, MAXIMUM PRESSURE IN PIPE, AND BEARING CAPACITY OF SOIL. PROTECT FITTINGS, BOLTS, ETC. BY COVERING WITH VISQUEEN OR OTHER ACCEPTABLE MATERIAL. CONCRETE SHALL BE A MINIMUM OF TWELVE INCHES (12") THICK.

PIPE SIZE	THRUST BLOCK AREA REQUIRED	PIPE SIZE	THRUST BLOCK AREA REQUIRED	REMARKS
4"	2.0 SQ. FT.	18"	30.0 SQ. FT.	VALUES ARE FOR 90° BENDS, BASED ON 2000 P.S.F. SAFE BEARING LOAD AND PIPE PRESSURE OF 150 P.S.I. PLUS 33% SAFETY FACTOR FOR OTHER SOILS AND PRESSURES, THE AREA REQUIRED IS IN DIRECT PROPORTION.
6"	4.0 SQ. FT.	20"	37.0 SQ. FT.	
8"	6.6 SQ. FT.	24"	53.0 SQ. FT.	
10"	10.0 SQ. FT.	27"	80.0 SQ. FT.	
12"	14.0 SQ. FT.	30"	98.0 SQ. FT.	
14"	18.0 SQ. FT.	36"	127.0 SQ. FT.	
16"	24.0 SQ. FT.			

* THE ENGINEER OF RECORD SHALL CALCULATE THE SIZE OF THE DEADMAN REQUIRED AS WELL AS ANY INSTALLATION WHICH IS NOT COVERED BY THE ABOVE.

SCALE: NOT TO SCALE



MARBLE FALLS
800 THIRD STREET
MARBLE FALLS, TX 78654
PH: (830) 693-6737

These documents were prepared by,
or under the supervision of:

ERIC BELAJ 107148 May 31, 2017
Engineer's Name PE# Date

Engineer's Signature

SECTION

WATER

DETAIL NO.

WT-30

TITLE

THRUST BLOCKING

FIRE HYDRANT AS SPECIFIED

2 1/2" X 3/4" HYDRANT ADAPTER

3/4" P.V.C. SHC. 40
OR COPPER

3/4" GATE VALVE

1'-6" MINIMUM

2'-0" MINIMUM

FINISHED GRADE

2'-6" MINIMUM
3'-0" TYPICAL

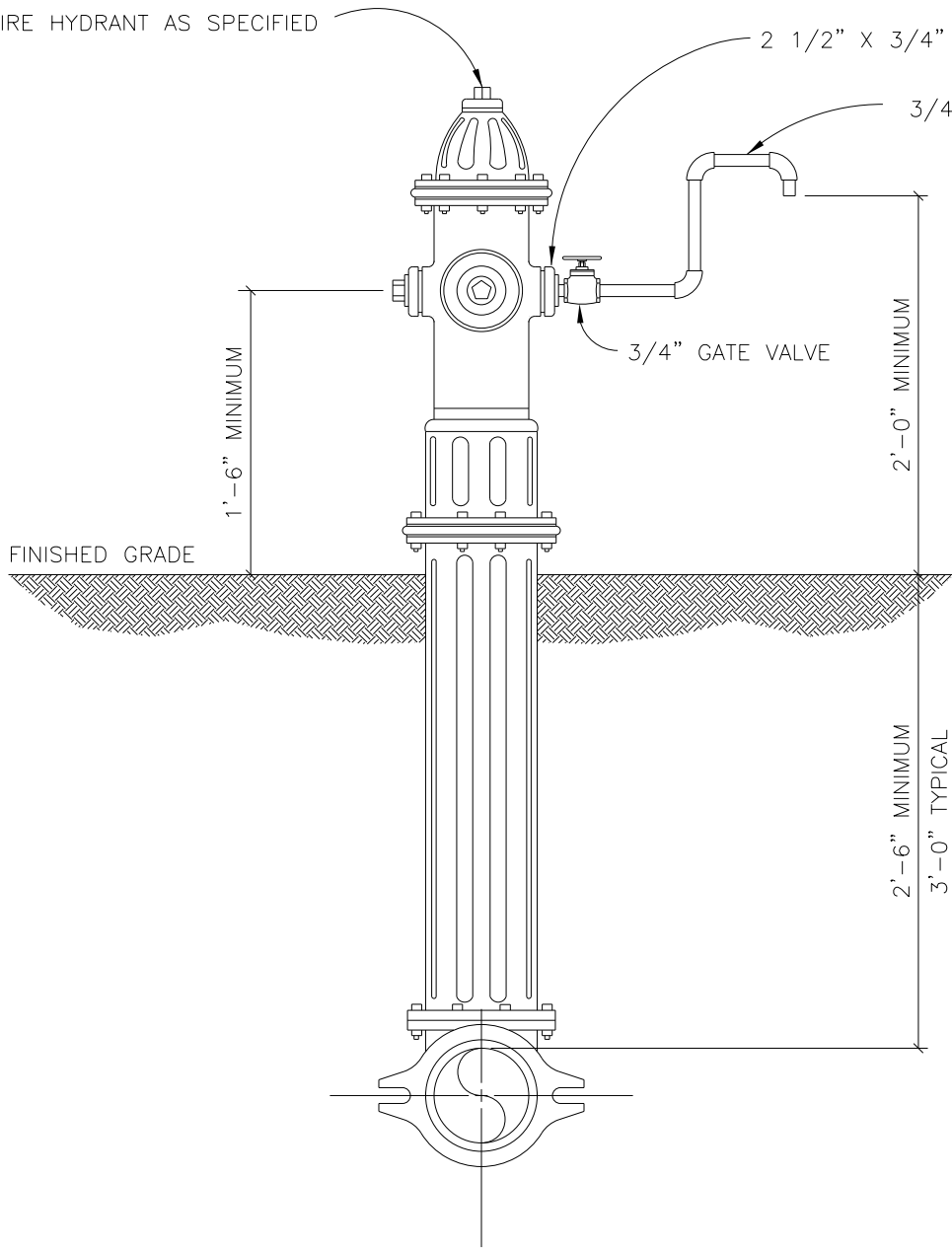

SCALE: NOT TO SCALE



MARBLE FALLS

800 THIRD STREET
MARBLE FALLS, TX 78654

PH: (830) 693-6737

These documents were prepared by,
or under the supervision of:

ERIC BELAJ 107148 May 31, 2017
Engineer's Name PE# Date

Engineer's Signature

SECTION

WATER

DETAIL NO.

WT-31

TITLE

FIRE HYDRANT
SAMPLE POINT

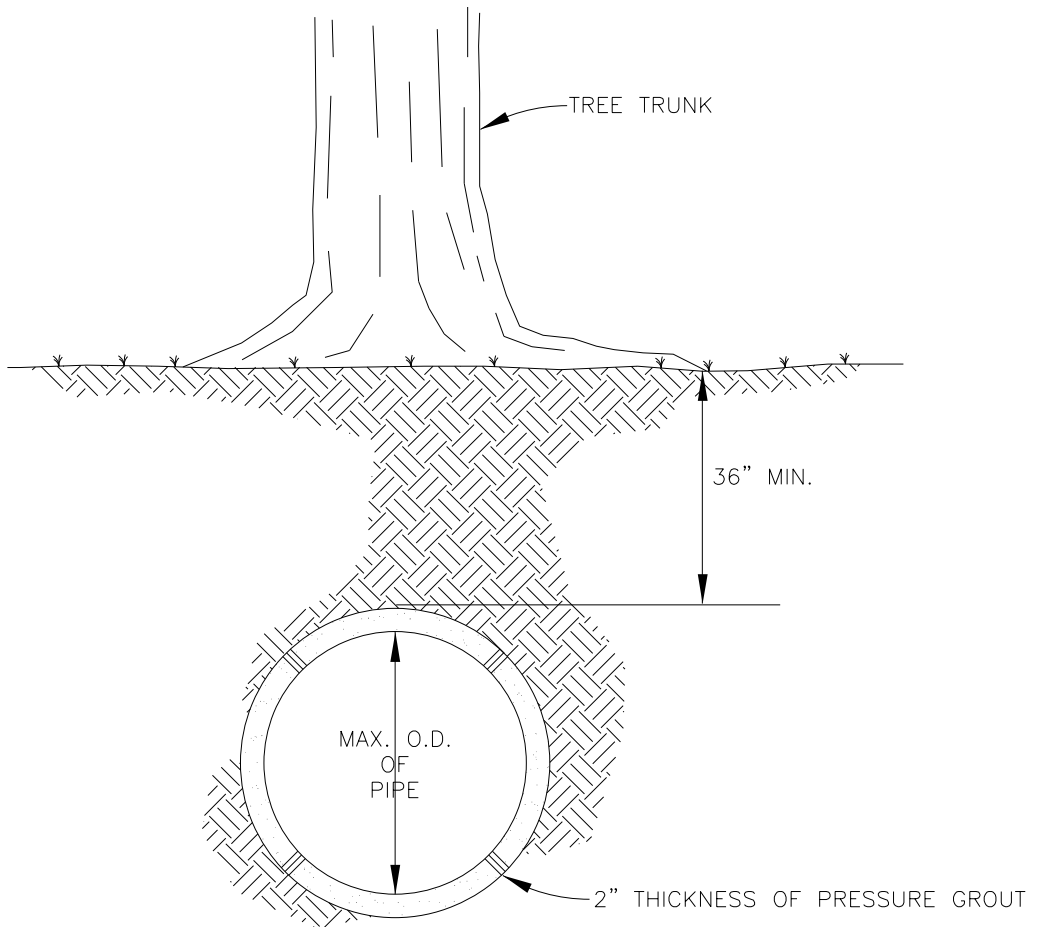

BORE & PRESSURE GROUT UNDER TREE

SCALE: N.T.S.

NOTE:

1. IF BORE IS THROUGH ROCK MATERIAL, BOTTOM OF PIPE BARREL SHALL BE SUPPORTED OFF BOTTOM WITH MORTAR BANDS ON C.S.C. PIPE OR STAINLESS STEEL CASING SPACERS ON D.I. OR PVC PIPE. IF BORE IS THROUGH DIRT MATERIAL, CLEAN BOTTOM OF BORE PIT TO REMOVE ROCKS PRIOR TO INSTALLING PIPE.

SCALE: NOT TO SCALE



MARBLE FALLS

800 THIRD STREET
MARBLE FALLS, TX 78654

PH: (830) 693-6737

These documents were prepared by,
or under the supervision of:

ERIC BELAJ	107148	May 31, 2017
Engineer's Name	PE#	Date

Engineer's Signature

SECTION

WATER

DETAIL NO.

WT-32

TITLE

BORE UNDER TREE

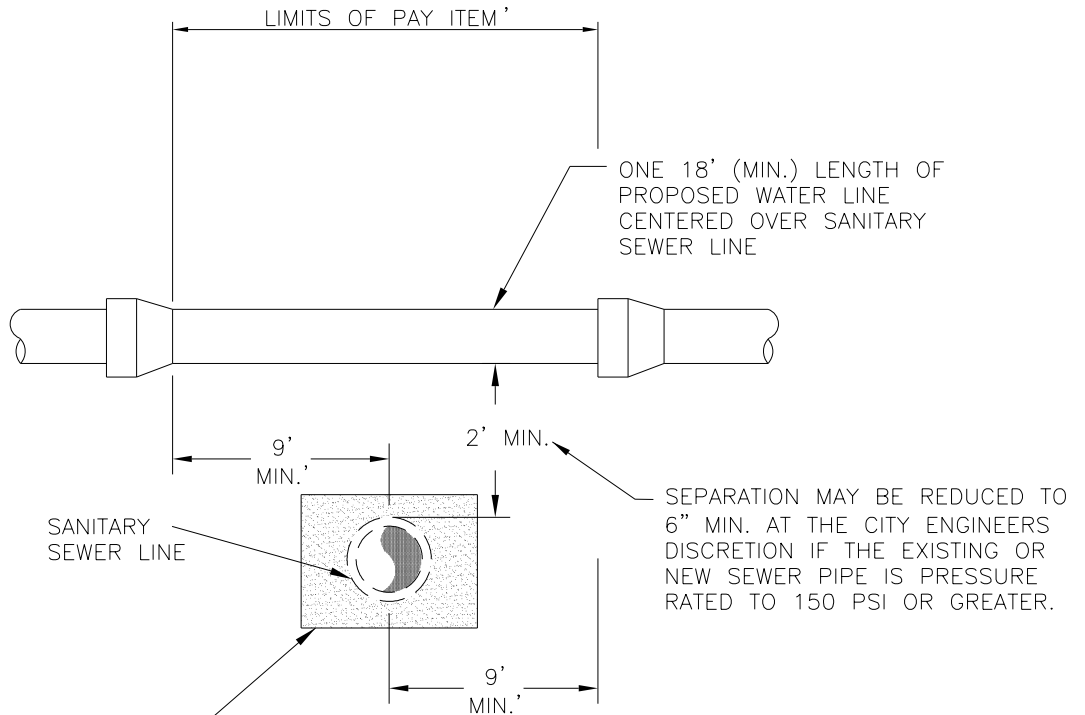

BED SANITARY SEWER LINE IN BROWN COLORED CEMENT STABILIZED SAND /MINIMUM CEMENT CONTENT OF 2.5 BAGS OF CEMENT PER CUBIC YARD. CEMENT STABILIZED SAND SHALL BE PLACED 6" ABOVE AND 4" BELOW THE WASTEWATER LINE FOR THE TOTAL LENGTH OF 1 PIPE SEGMENT PLUS 12 INCHES BEYOND THE JOINT AT EACH END.

NOTES:

1. PIPE CENTERED WITH 2' SEPARATION, CENTER CROSSING OVER SEGMENT OF WASTE WATER LINE WHEN POSSIBLE. IF EXISTING WASTE WATER MAIN IS DISTURBED OR SHOW SIGNS OF LEAKAGE NOTIFY ENGINEER IMMEDIATELY.

* ALL CROSSINGS SHALL COMPLY WITH CURRENT TCEQ REQUIREMENTS AND IN ACCORDANCE WITH AWWA AND/OR ASTM STANDARDS.

SCALE: NOT TO SCALE



MARBLE FALLS
800 THIRD STREET
MARBLE FALLS, TX 78654
PH: (830) 693-6737

These documents were prepared by,
or under the supervision of:

ERIC BELAJ 107148 May 31, 2017
Engineer's Name PE# Date

Engineer's Signature

SECTION

WATER

DETAIL NO.

WT-33

TITLE

WASTEWATER LINE UNDER
WATER MAIN CROSSING

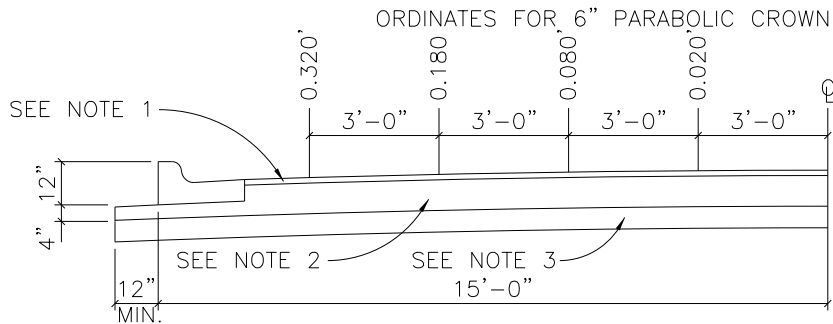
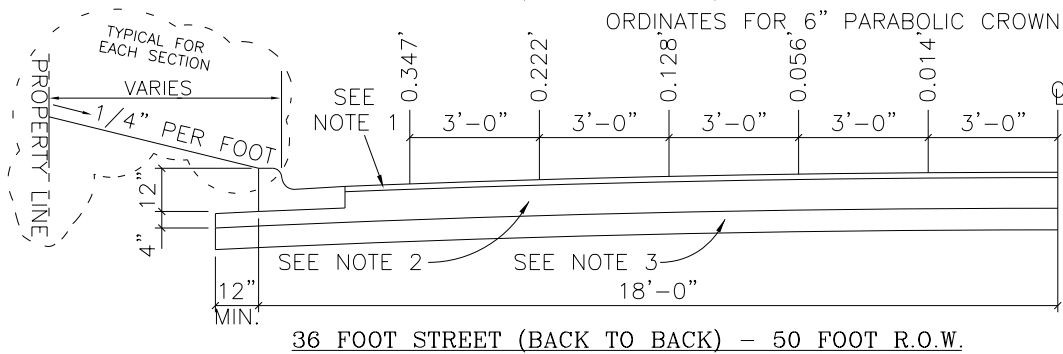
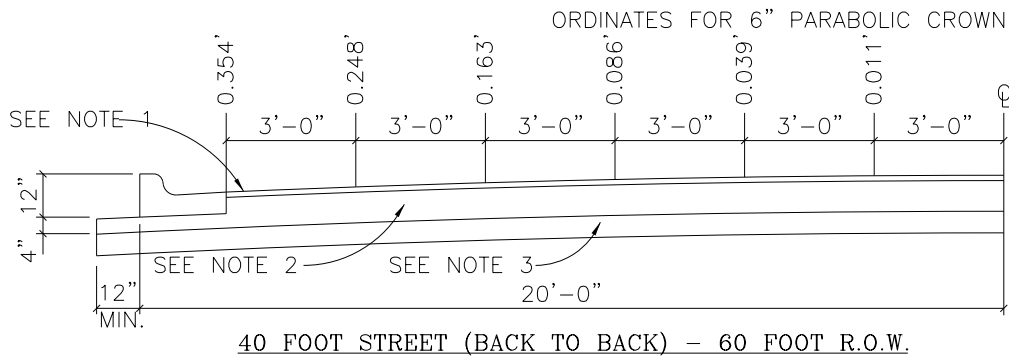
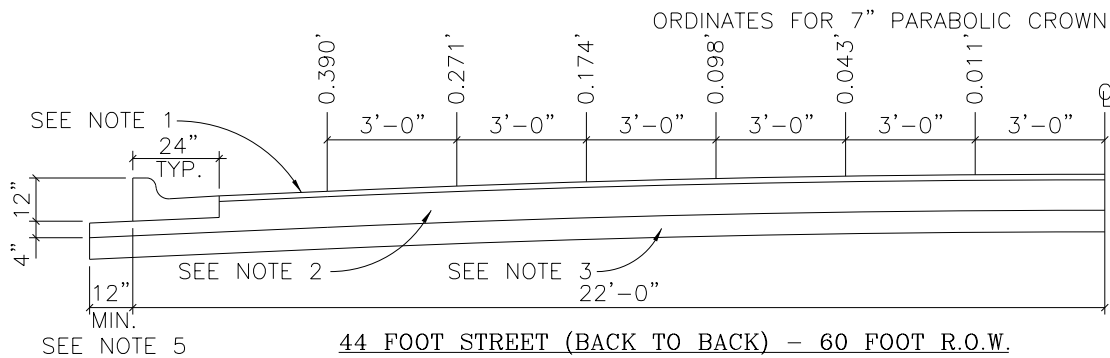

NOTES:

1. 1 1/2" HOT MIX ASPHALTIC CONCRETE.
2. FLEXIBLE BASE COURSE; VARIES IN THICKNESS FROM MINIMUM 8".
3. 6" LIME STABILIZED SUBGRADE OR SELECT SUBBASE MATERIAL AS REQUIRED.
4. COMBINED THICKNESS OF FLEXIBLE BASE COURSE, TREATED SUBGRADE OR SUBBASE SHALL BE AS REQUIRED TO SUPPORT TRAFFIC LOADS AND VOLUME ON SUBGRADE.
5. GEOTECHNICAL REPORT MAY REQUIRE BASE MATERIAL GREATER THAN 12" BEHIND CURB.

SCALE: NOT TO SCALE



MARBLE FALLS
800 THIRD STREET
MARBLE FALLS, TX 78654
PH: (830) 693-6737

These documents were prepared by,
or under the supervision of:

ERIC BELAJ 107148 May 31, 2017
Engineer's Name PE# Date

Engineer's Signature

SECTION

PAVING

DETAIL NO.

PV-1

TITLE

HMAC PAVEMENT SECTION

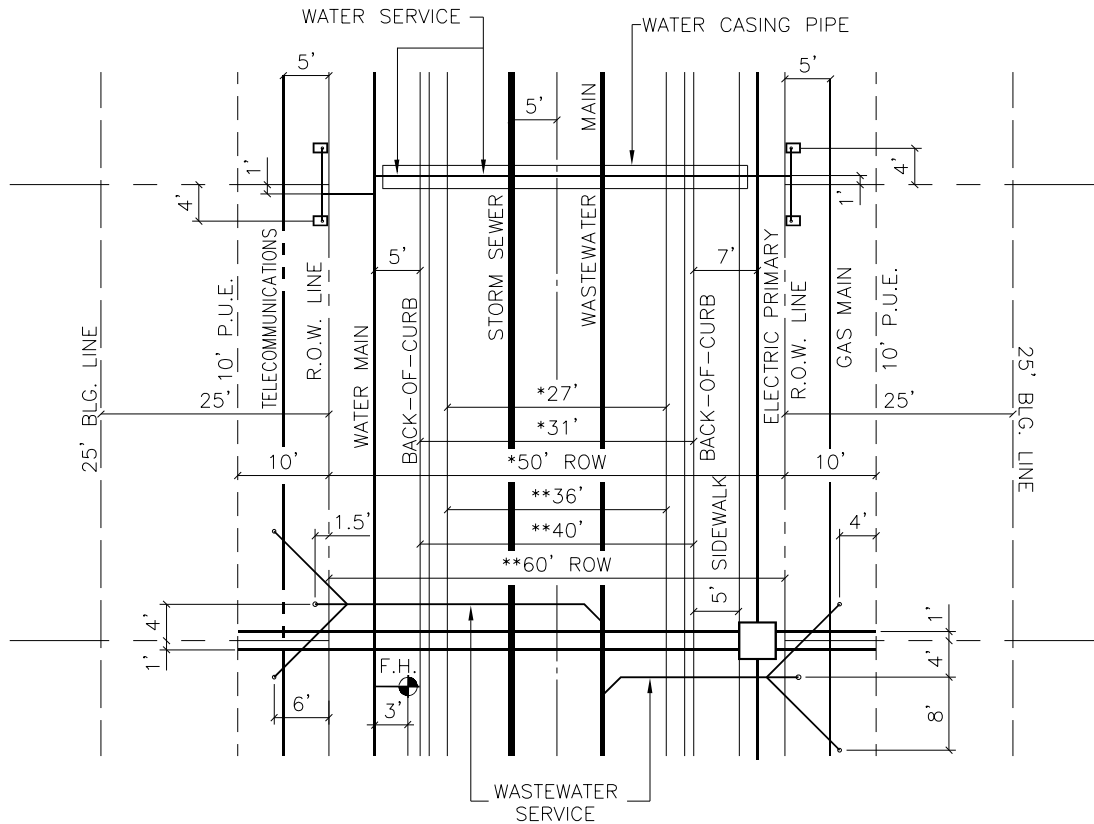

MINIMUM COVER BELOW FINISH-GRADE

ELECTRIC PRIMARY	36"
ELECTRIC SECONDARY	24"
WATER	36"
WASTEWATER	48"
STORM SEWER	24"
GAS	24"
TELECOMMUNICATIONS	24"

*LOCAL RESIDENTIAL STREET

NOT TO SCALE

**RESIDENTIAL COLLECTOR STREET

NOT TO SCALE

NOTE:

1. REFER TO ROAD SECTION WITH TYPICAL UTILITY ASSIGNMENTS FOR SECTION VIEWS FOR MAIN UTILITY AND COMMUNICATION LINE LOCATIONS.
2. SET EDGE OF WATER METER BOX ON PROPERTY/R.O.W. LINE.

SCALE: NOT TO SCALE



MARBLE FALLS

800 THIRD STREET
MARBLE FALLS, TX 78654

PH: (830) 693-6737

These documents were prepared by,
or under the supervision of:

ERIC BELAJ 107148 May 31, 2017
Engineer's Name PE# Date

Engineer's Signature

SECTION

PAVING

DETAIL NO.

PV-2

TITLE

PAVING & UTILITY LAYOUT
PLAN (1 OF 2)

* LOCAL RESIDENTIAL STREET
 ** RESIDENTIAL COLLECTOR STREET

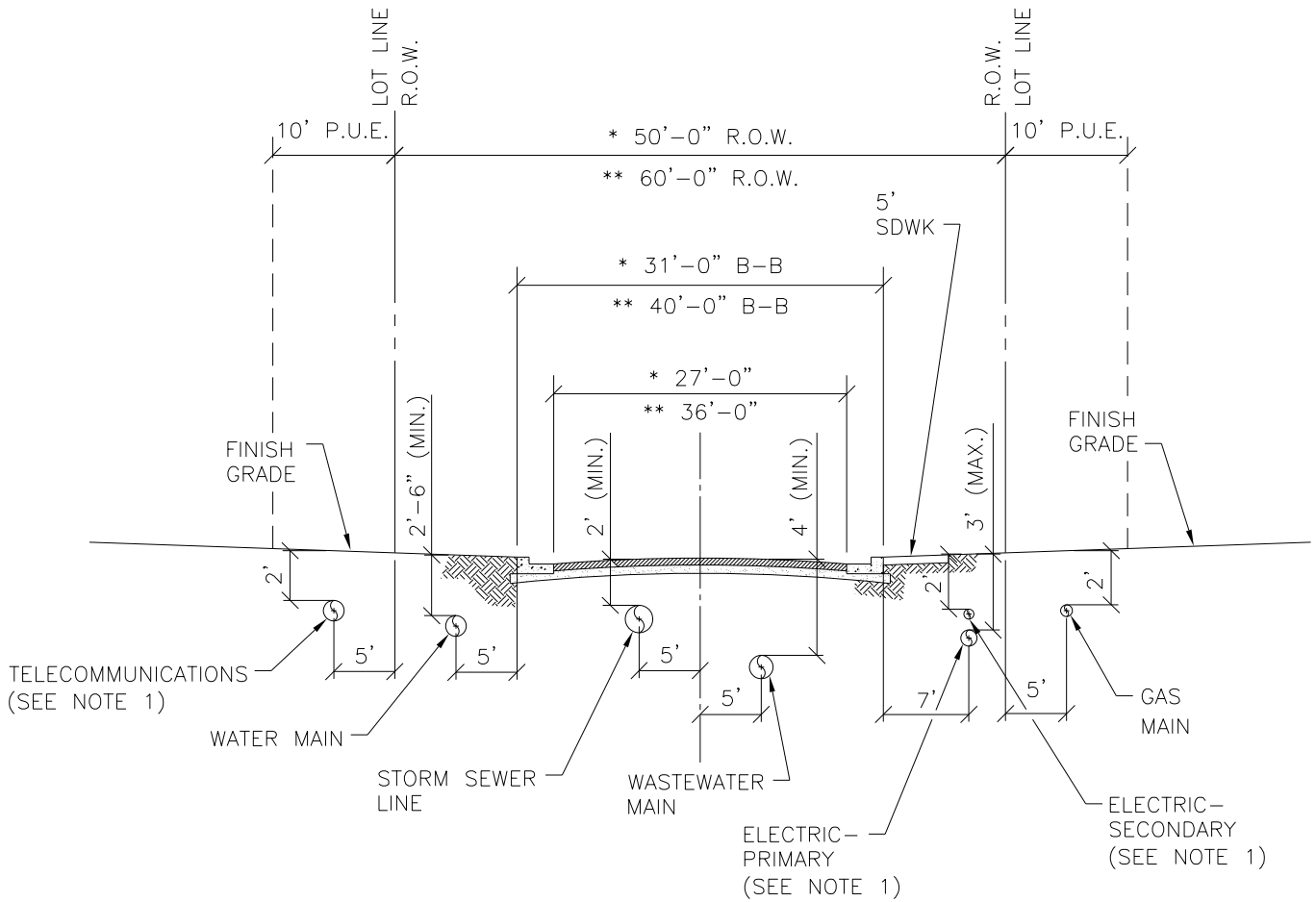

NOTE:

1. WHEN USING JOINT TRENCH FOR ELECTRIC AND TELECOMMUNICATIONS, GAS MAIN WILL BE LOCATED ON THE OPPOSITE SIDE OF THE STREET FROM THE JOINT TRENCH.

SCALE: NOT TO SCALE



MARBLE FALLS
 800 THIRD STREET
 MARBLE FALLS, TX 78654
 PH: (830) 693-6737

These documents were prepared by,
 or under the supervision of:

ERIC BELAJ 107148 May 31, 2017
 Engineer's Name PE# Date

Engineer's Signature

SECTION

PAVING

DETAIL NO.

PV-3

TITLE

PAVING & UTILITY LAYOUT
 SECTION (2 OF 2)

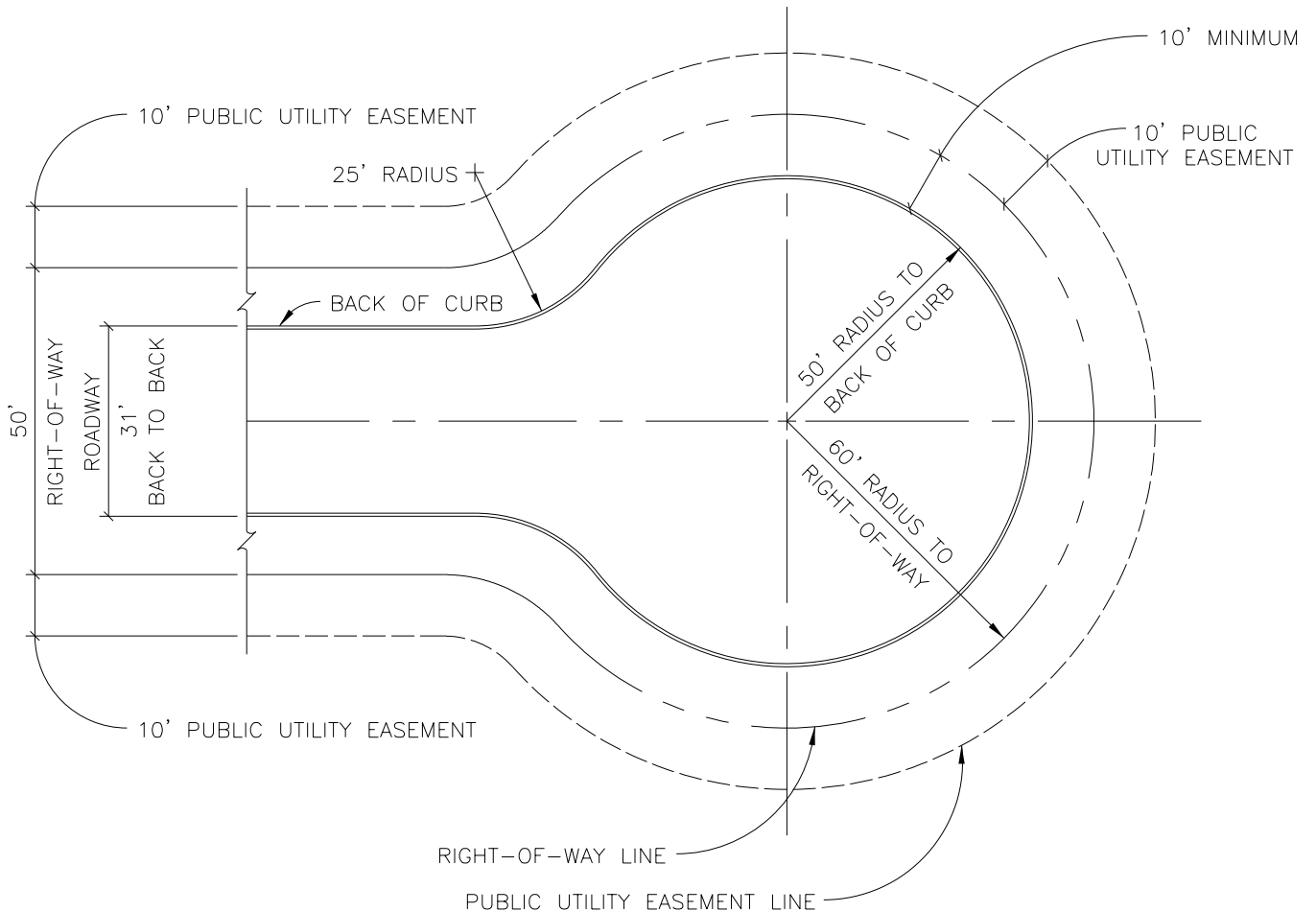

NOTE:

1. CUL-DE-SAC SHALL BE CONSTRUCTED WITH A MINIMUM 1.5% ROADWAY SLOPE TO ENSURE PROPER DRAINAGE, WITH A 9-INCH CROWN.

SCALE: NOT TO SCALE



MARBLE FALLS
 800 THIRD STREET
 MARBLE FALLS, TX 78654
 PH: (830) 693-6737

These documents were prepared by,
 or under the supervision of:

ERIC BELAJ 107148 May 31, 2017
 Engineer's Name PE# Date

Engineer's Signature

SECTION

PAVING

DETAIL NO.

PV-4

TITLE

RESIDENTIAL CUL-DE-SAC

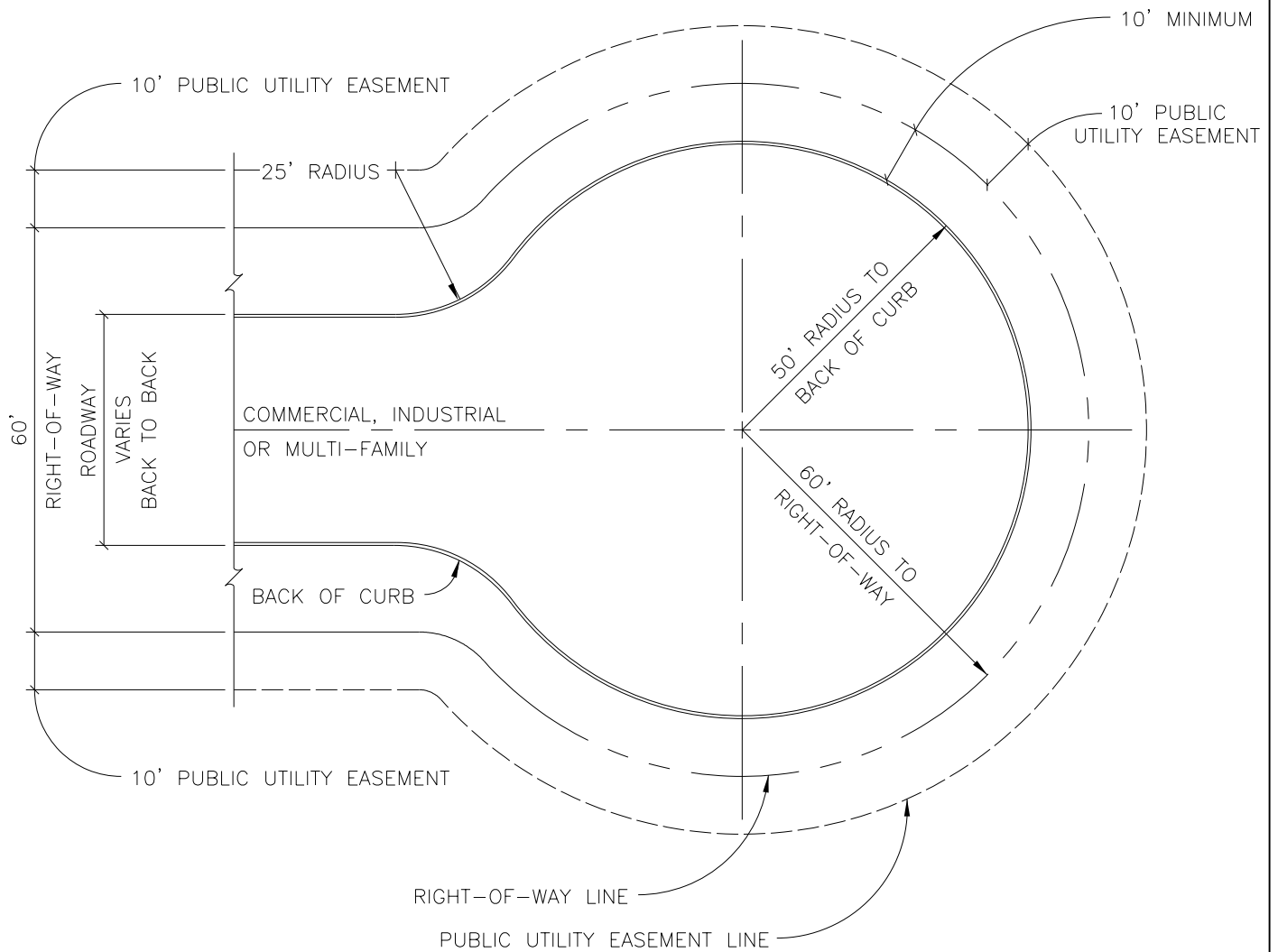

NOTE:

1. CUL-DE-SAC SHALL BE CONSTRUCTED WITH A MINIMUM 1.5% ROADWAY SLOPE TO ENSURE PROPER DRAINAGE, WITH A 9-INCH CROWN.

SCALE: NOT TO SCALE



MARBLE FALLS
800 THIRD STREET
MARBLE FALLS, TX 78654
PH: (830) 693-6737

These documents were prepared by,
or under the supervision of:

ERIC BELAJ 107148 May 31, 2017
Engineer's Name PE# Date

Engineer's Signature

SECTION

PAVING

DETAIL NO.

PV-5

TITLE

COMMERCIAL CUL-DE-SAC

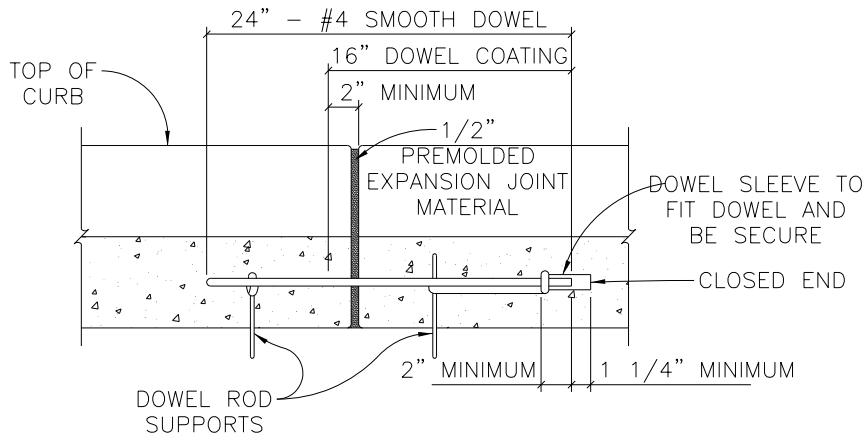
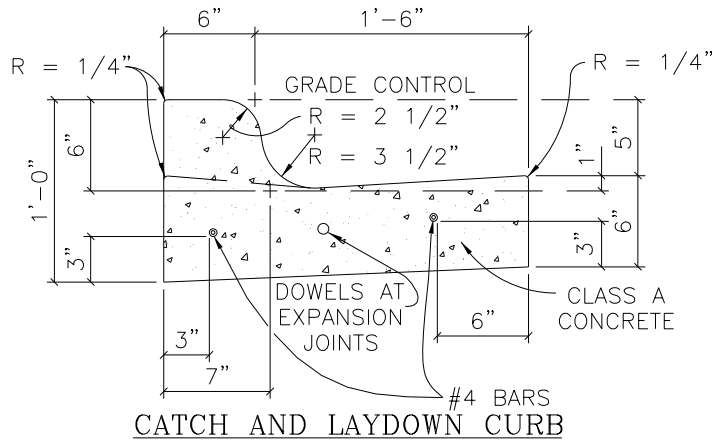
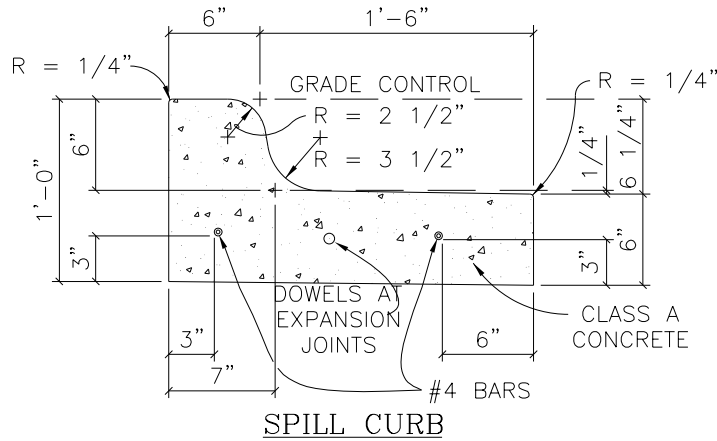

NOTES:

1. EXPANSION JOINT INTERVALS NOT TO EXCEED 40'-0".
2. "SCORE" CURB AT 10'-0" INTERVALS.

SCALE: NOT TO SCALE



MARBLE FALLS
 800 THIRD STREET
 MARBLE FALLS, TX 78654
 PH: (830) 693-6737

These documents were prepared by,
 or under the supervision of:

ERIC BELAJ 107148 May 31, 2017
 Engineer's Name PE# Date

[Signature]
 Engineer's Signature

SECTION
PAVING

DETAIL NO.
PV-6

TITLE
 STANDARD CURB SECTION

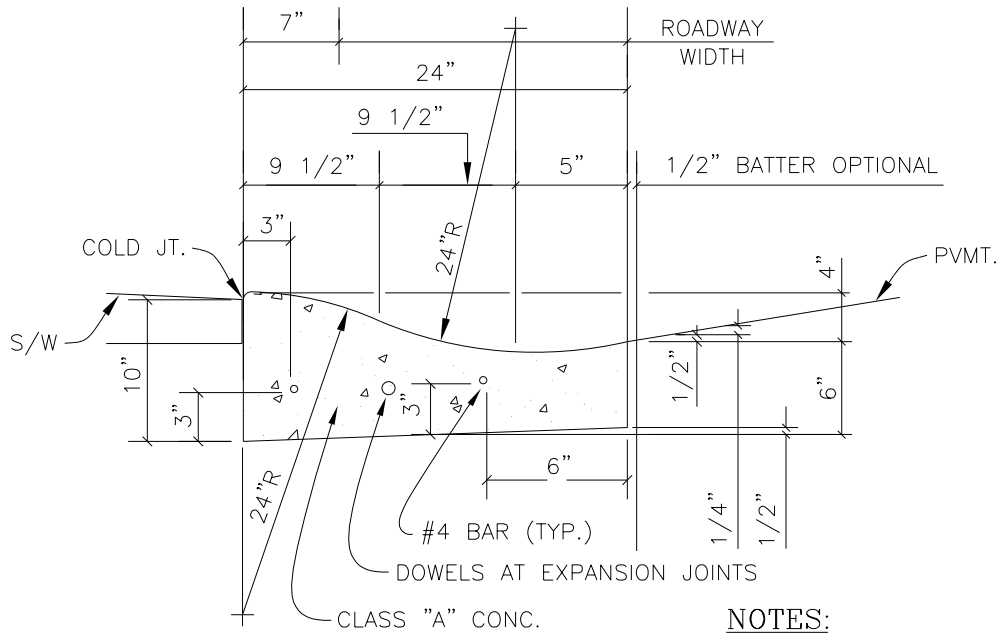

MOUNTABLE CURB

NOTES:

1. ALL WORK AND MATERIAL SHALL CONFORM TO ASTM A615, A615M, C309, AND D1752. BROOM FINISH EXPOSED SURFACE.
2. CONTRACTION JOINT SPACING 10' MAX.
3. EXPANSION JOINTS AS PER STD. ASTM D-1752.

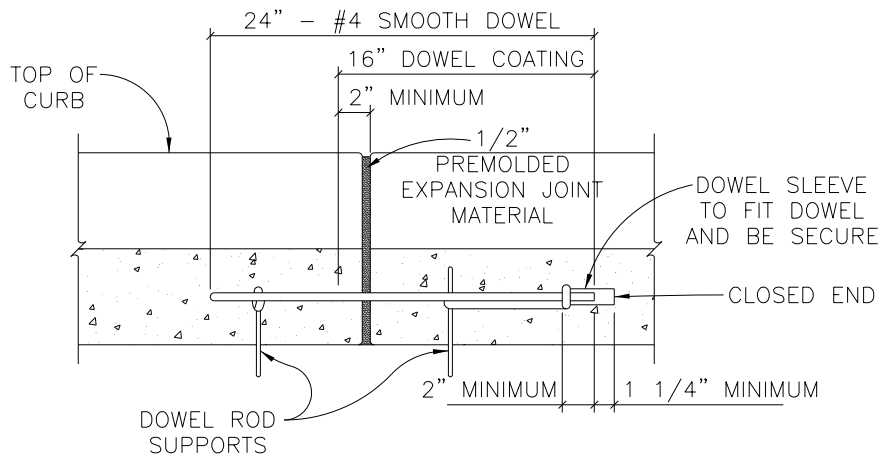

CURB DOWEL DETAIL

NOTES:

1. EXPANSION JOINT INTERVALS NOT TO EXCEED 40'-0".
2. "SCORE" CURB AT 10'-0" INTERVALS.

SCALE: NOT TO SCALE



MARBLE FALLS
800 THIRD STREET
MARBLE FALLS, TX 78654
PH: (830) 693-6737

These documents were prepared by,
or under the supervision of:

ERIC BELAJ 107148 May 31, 2017
Engineer's Name PE# Date

[Signature]
Engineer's Signature

SECTION

PAVING

DETAIL NO.

PV-7

TITLE

MOUNTABLE CURB SECTION

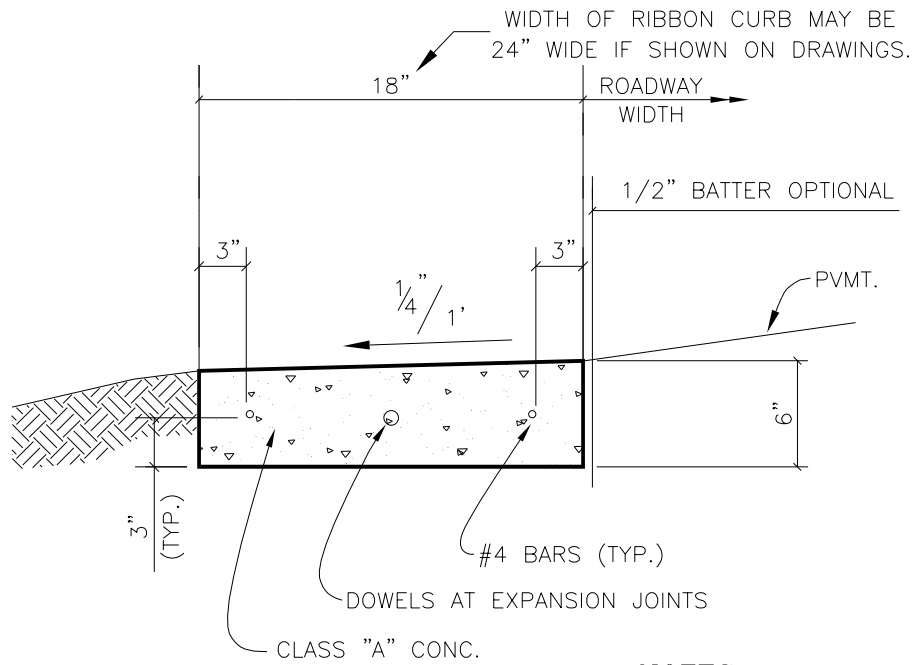

RIBBON CURB

NOTES:

1. ALL WORK AND MATERIAL SHALL CONFORM TO ASTM A615, A615M, C309, AND D1752. BROOM FINISH EXPOSED SURFACE.
2. CONTRACTION JOINT SPACING 10' MAX.
3. EXPANSION JOINTS AS PER STD. ASTM D-1752.

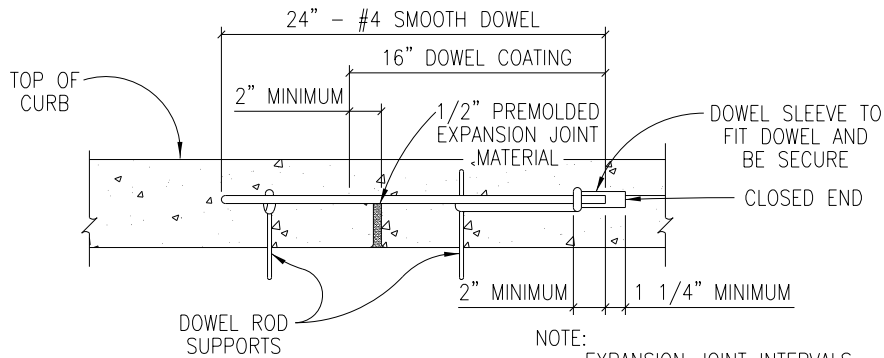

NOTE:
EXPANSION JOINT INTERVALS NOT TO EXCEED 40'-0".

CURB DOWEL DETAIL

NOTES:

1. EXPANSION JOINT INTERVALS NOT TO EXCEED 40'-0".
2. "SCORE" CURB AT 10'-0" INTERVALS.

SCALE: NOT TO SCALE



MARBLE FALLS
800 THIRD STREET
MARBLE FALLS, TX 78654
PH: (830) 693-6737

These documents were prepared by,
or under the supervision of:

ERIC BELAJ 107148 May 31, 2017
Engineer's Name PE# Date

Engineer's Signature

SECTION

PAVING

DETAIL NO.

PV-8

TITLE

RIBBON CURB SECTION

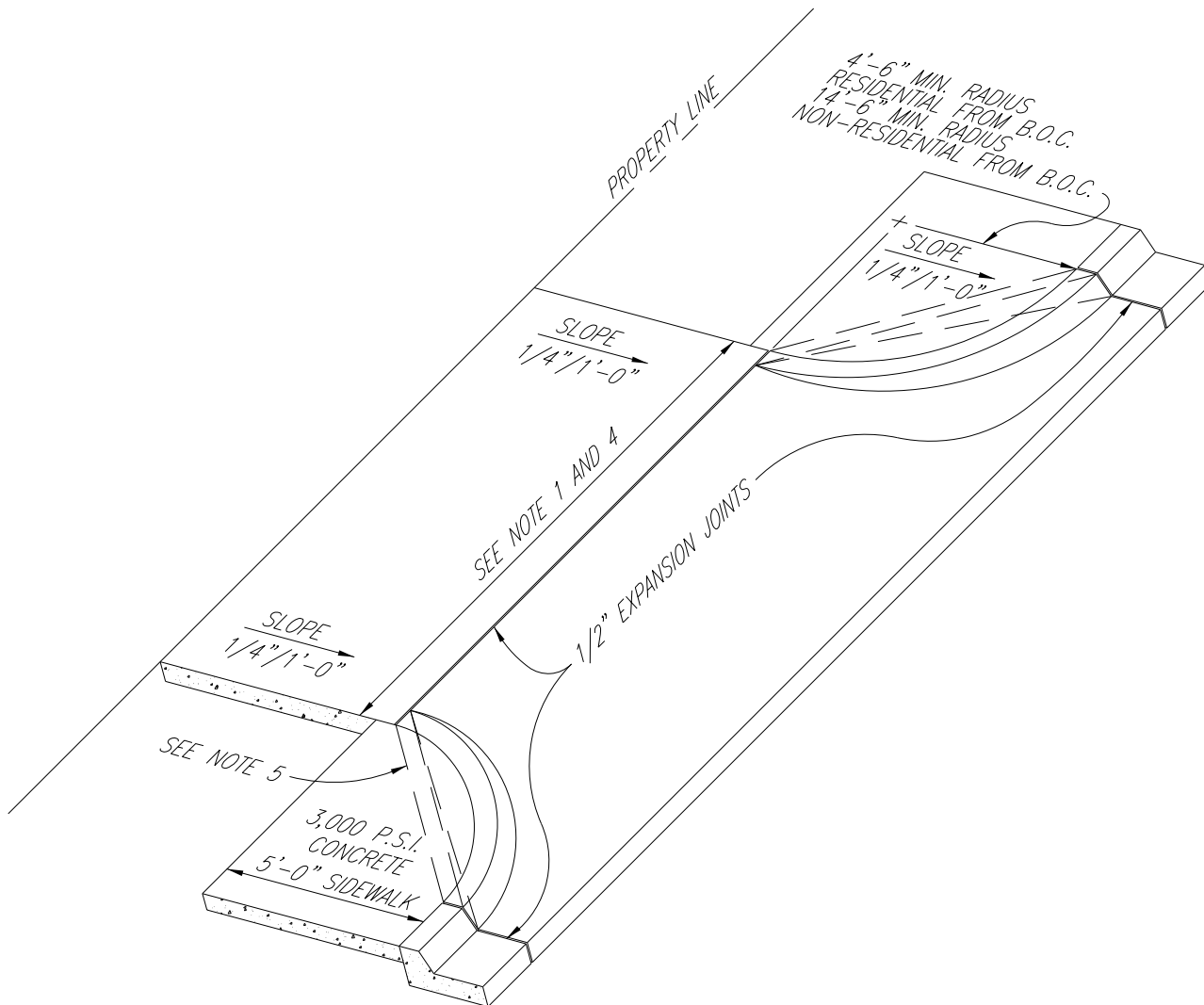

NOTES:

1. MAXIMUM WIDTH OF APPROACH SHALL BE 24'-0" FOR RESIDENTIAL, 30'-0" FOR NON-RESIDENTIAL UNDIVIDED AND 45'-0" FOR NON-RESIDENTIAL DIVIDED.
2. DRIVEWAY PERMITS TO BE ACQUIRED FROM CITY INSPECTION OFFICE.
3. SPACING OF DRIVEWAY CUTS SHALL BE AS REQUIRED BY SECTIONS 33043 - 33044 OF THE CITY'S SUBDIVISION REGULATIONS.
4. MINIMUM WIDTH OF APPROACH SHALL BE 10'-0" FOR RESIDENTIAL AND 15'-0" FOR NON-RESIDENTIAL.
5. LINEAR "RADIUS" AT CORNERS, PERMITTED FOR "SINGLE FAMILY" OR "TWO FAMILY" RESIDENTIAL DRIVEWAY APPROACH.

SCALE: NOT TO SCALE



MARBLE FALLS
 800 THIRD STREET
 MARBLE FALLS, TX 78654
 PH: (830) 693-6737

These documents were prepared by,
 or under the supervision of:

ERIC BELAJ 107148 May 31, 2017
 Engineer's Name PE# Date

Engineer's Signature

SECTION

PAVING

DETAIL NO.

PV-9

TITLE

DRIVEWAY APPROACH
 TYPE 'A'

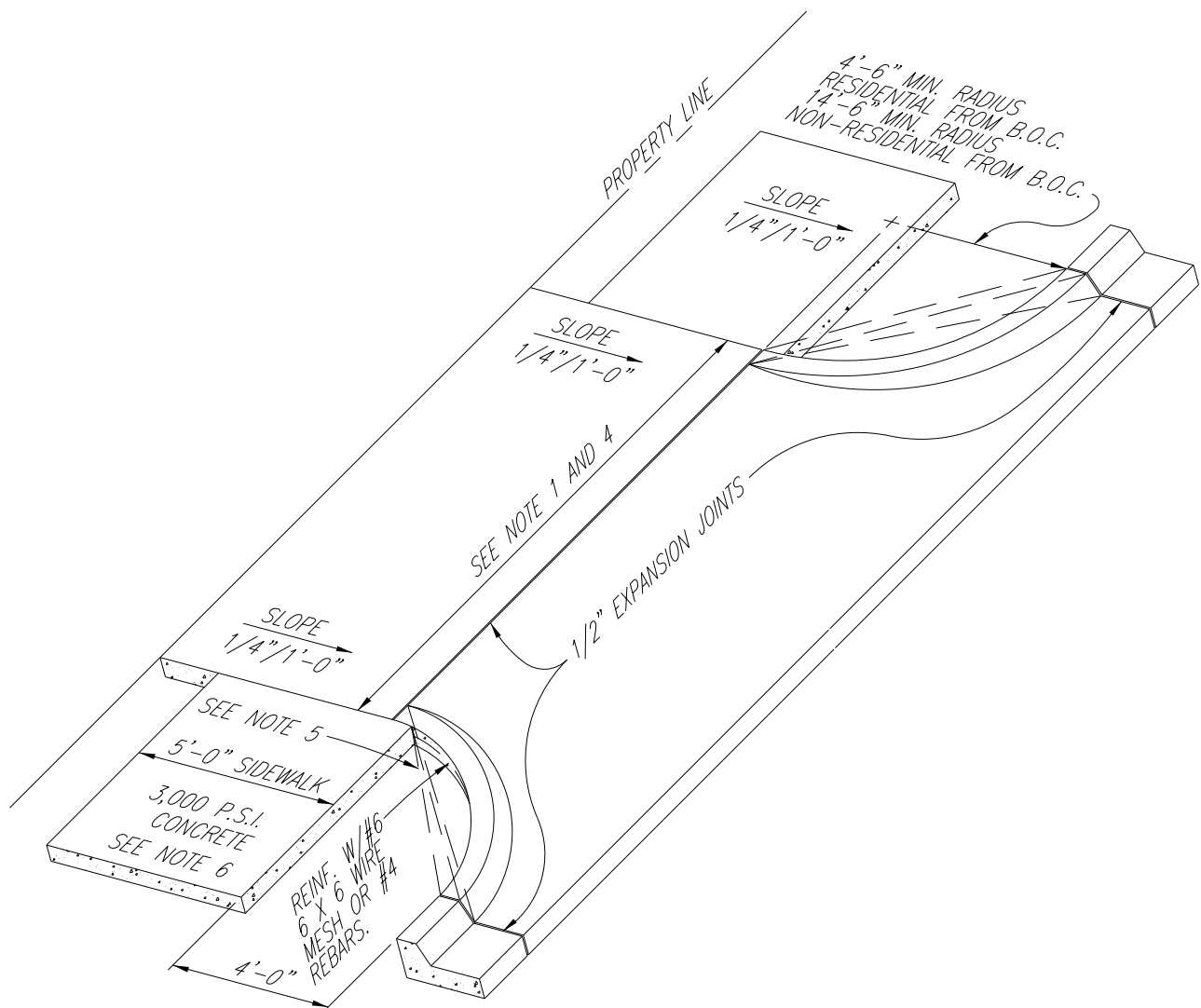

NOTES:

1. MAXIMUM WIDTH OF APPROACH SHALL BE 24'-0" FOR RESIDENTIAL, 30'-0" FOR NON-RESIDENTIAL UNDIVIDED AND 45'-0" FOR NON-RESIDENTIAL DIVIDED.
2. DRIVEWAY PERMITS TO BE ACQUIRED FROM CITY INSPECTION OFFICE.
3. SPACING OF DRIVEWAY CUTS SHALL BE AS REQUIRED BY SECTIONS 33043 - 33044 OF THE CITY'S SUBDIVISION REGULATIONS.
4. MINIMUM WIDTH OF APPROACH SHALL BE 10'-0" FOR RESIDENTIAL AND 15'-0" FOR NON-RESIDENTIAL.
5. LINEAR "RADIUS" AT CORNERS, PERMITTED FOR "SINGLE FAMILY" OR "TWO FAMILY" RESIDENTIAL DRIVEWAY APPROACH.
6. SIDEWALK LOCATION TO BE APPROVED BY CITY ENGINEER PRIOR TO FINAL DESIGN.

SCALE: NOT TO SCALE



MARBLE FALLS
800 THIRD STREET
MARBLE FALLS, TX 78654
PH: (830) 693-6737

These documents were prepared by,
or under the supervision of:

ERIC BELAJ 107148 May 31, 2017
Engineer's Name PE# Date

Engineer's Signature

SECTION

PAVING

DETAIL NO.

PV-10

TITLE

DRIVEWAY APPROACH
TYPE 'B'

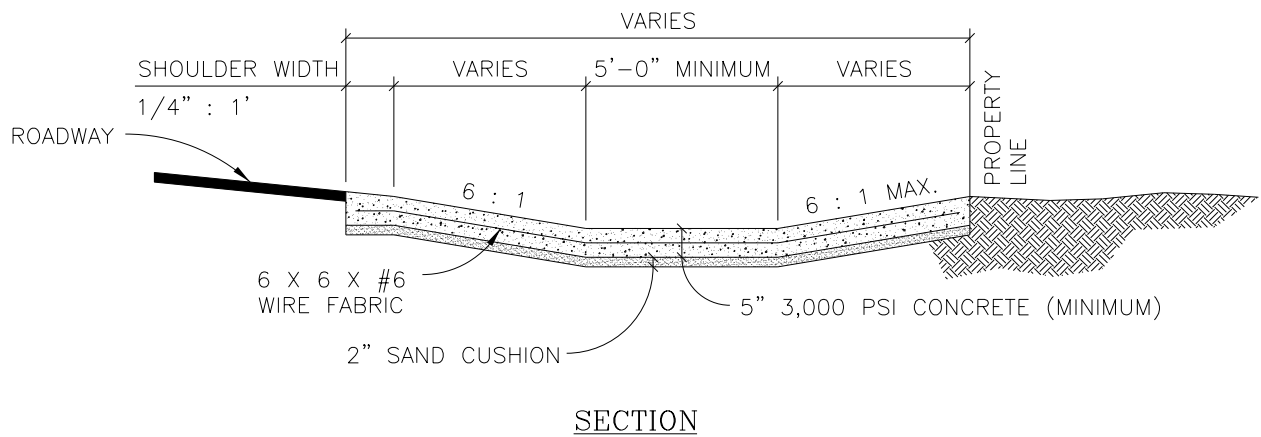
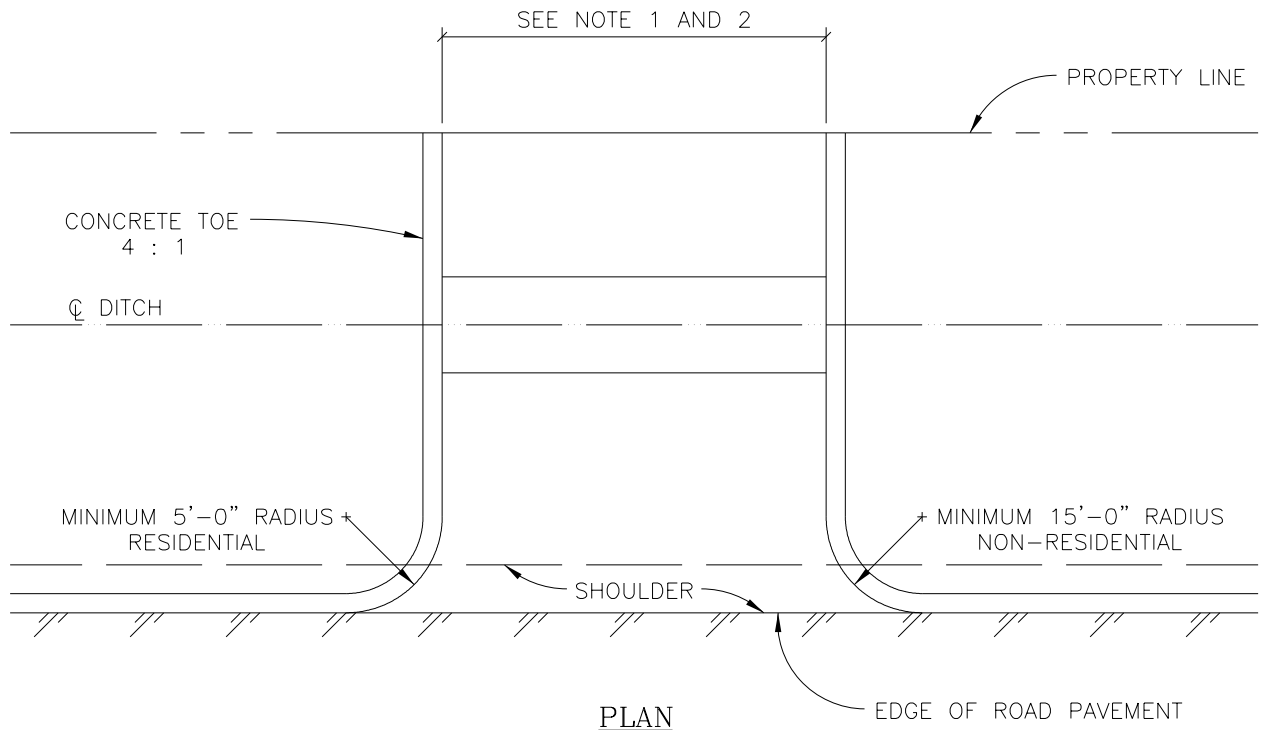

NOTES:

1. MINIMUM WIDTH OF APPROACH SHALL BE 12'-0" FOR RESIDENTIAL AND 15'-0" FOR NON-RESIDENTIAL.
2. MAXIMUM WIDTH OF APPROACH SHALL BE 24'-0" FOR RESIDENTIAL, 30'-0" FOR NON-RESIDENTIAL UNDIVIDED AND 45'-0" FOR NON-RESIDENTIAL DIVIDED.

SCALE: NOT TO SCALE



MARBLE FALLS
800 THIRD STREET
MARBLE FALLS, TX 78654
PH: (830) 693-6737

These documents were prepared by,
or under the supervision of:

ERIC BELAJ 107148 May 31, 2017
Engineer's Name PE# Date

[Signature]
Engineer's Signature

SECTION

PAVING

DETAIL NO.

PV-11

TITLE

DITCH DRIVEWAY APPROACH
TYPE 'C'

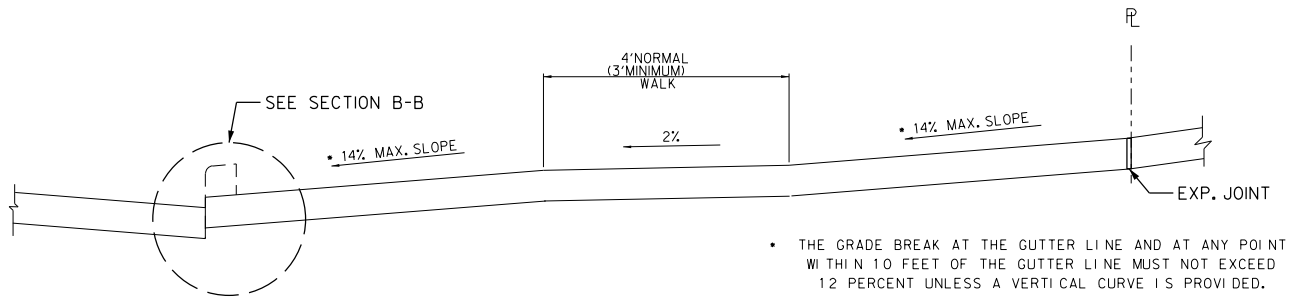

• THE GRADE BREAK AT THE GUTTER LINE AND AT ANY POINT WITHIN 10 FEET OF THE GUTTER LINE MUST NOT EXCEED 12 PERCENT UNLESS A VERTICAL CURVE IS PROVIDED.

SECTION A-A

N.T.S.

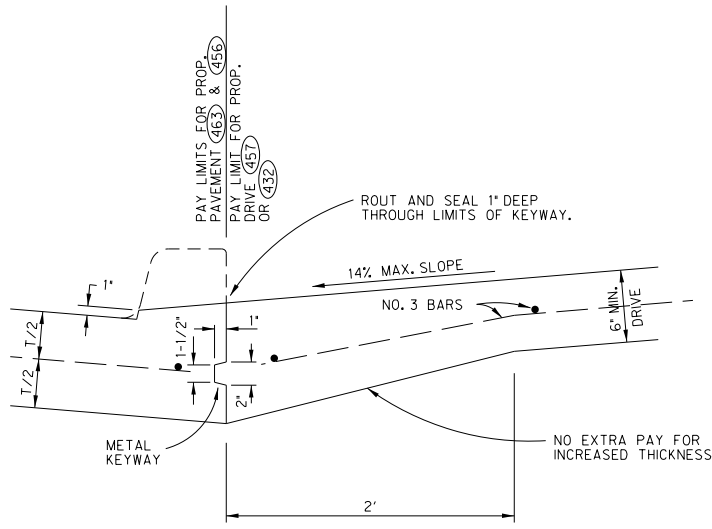

SECTION B-B

N.T.S.

NOTES:

1. ALL SAWED DUMMY JOINTS SHALL BE SEALED WITH EZ-7 OR APPROVED EQUAL COLD POUR JOINT SEALANT.
2. TOOLED OR SAWED JOINT WILL BE REQUIRED AT CENTERLINE OF ALL DRIVEWAYS LESS THAN 24' WIDE. ADDITIONAL JOINTS WILL BE REQUIRED AT EQUAL SPACINGS FOR DRIVEWAYS WIDER THAN 24'.
3. OFFSETS IN DRIVES TO MATCH PROPOSED WALKS WILL BE BUILT MONOLITHIC WITH THE DRIVE.
4. PAVEMENT JOINTS WILL NOT EXTEND THROUGH DRIVE EXCEPT AS PROVIDED FOR IN NOTES 9 AND 10 BELOW FOR CENTERLINE DRIVEWAY JOINTS.
5. KEYWAY LIMITS WILL COINCIDE WITH LIMITS OF 1' CURB.
6. REINFORCING STEEL WILL NOT EXTEND THROUGH KEYWAY. DRIVE WILL NOT BE TIED TO PAVEMENT.
7. LENGTH OF TRANSITION FOR CURB AT EACH SIDE OF DRIVE MAY VARY DUE TO STREET GRADES AND REQUIREMENT TO HOLD MAXIMUM SLOPE OF 1 1/2'.
8. AN EXPANSION JOINT WILL BE REPLACED AT THE PROPERTY LINE.
9. TRANSVERSE SAWED DUMMY JOINTS SHALL BE CONSTRUCTED ON 15' SPACINGS FOR DRIVEWAYS AS MEASURED FROM THE BACK OF CURB.
10. LONGITUDINAL SAWED OR TOOLED DUMMY JOINTS SHALL BE CONSTRUCTED FROM THE GUTTER EDGE TO THE PROPERTY LINE FOR ALL DRIVEWAYS WIDER THAN 15'.
11. STREET JOINTS SHALL BE ADJUSTED IN LOCATIONS TO LINE UP WITH DRIVEWAY CENTERLINES.

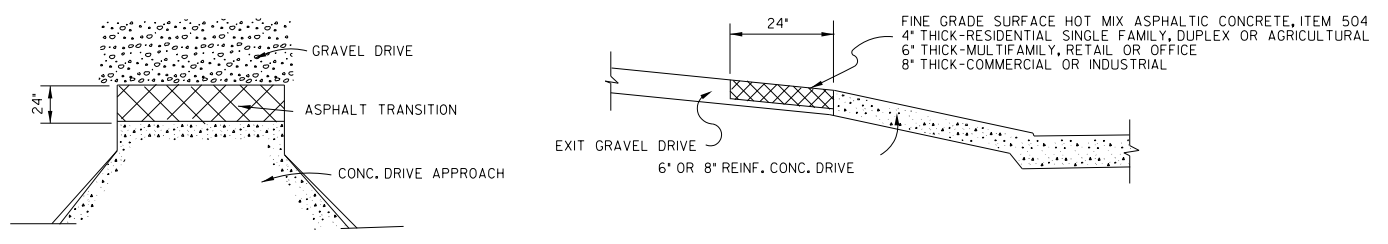

CONCRETE DRIVEWAY CONNECTION TO GRAVEL SECTION

N.T.S.

SCALE: NOT TO SCALE



MARBLE FALLS
800 THIRD STREET
MARBLE FALLS, TX 78654
PH: (830) 693-6737

These documents were prepared by,
or under the supervision of:

ERIC BELAJ 107148 May 31, 2017
Engineer's Name PE# Date

Engineer's Signature

SECTION	PAVING
DETAIL NO.	PV-12
TITLE	DRIVEWAY SECTION TYPE '1'

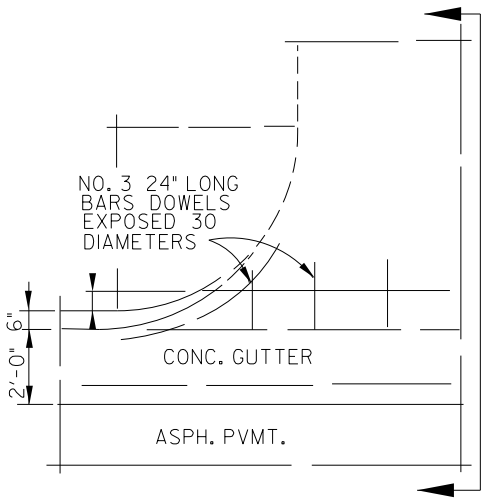
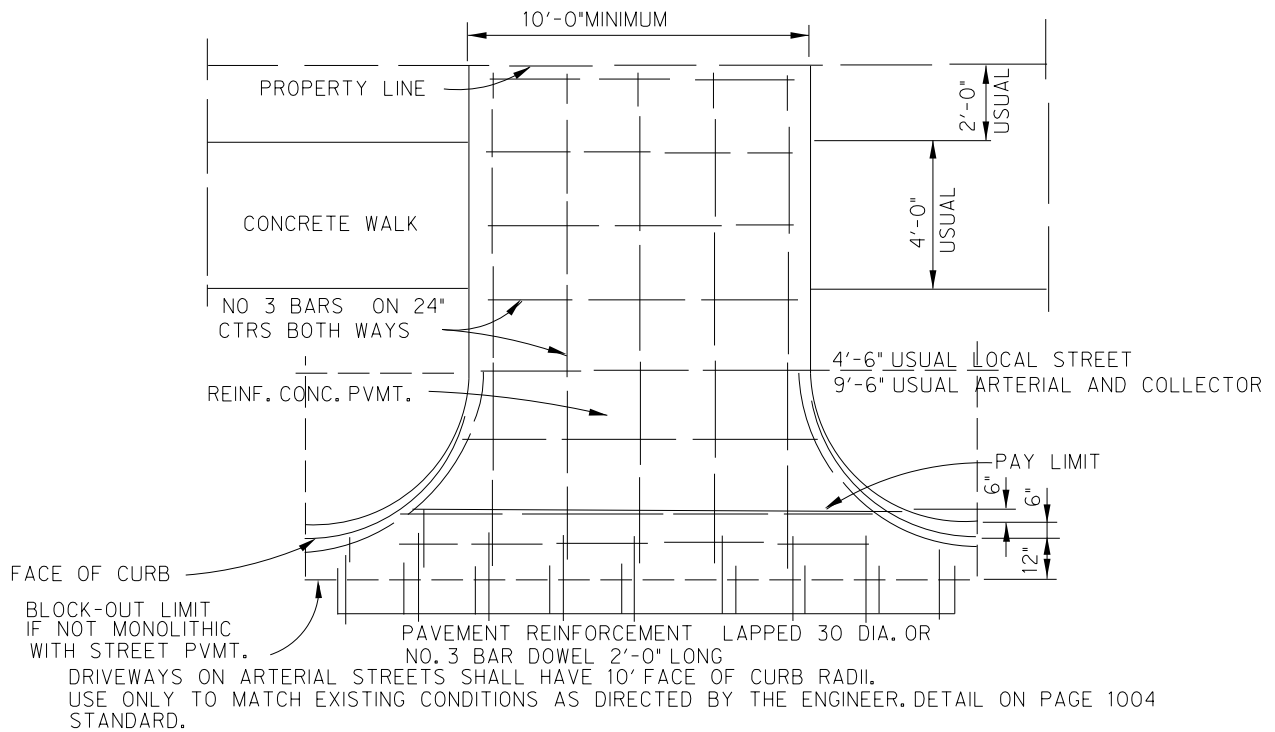

HALF PLAN ASPH. CONC. PVMT. WITH SEPARATE CONC. CURB AND GUTTER

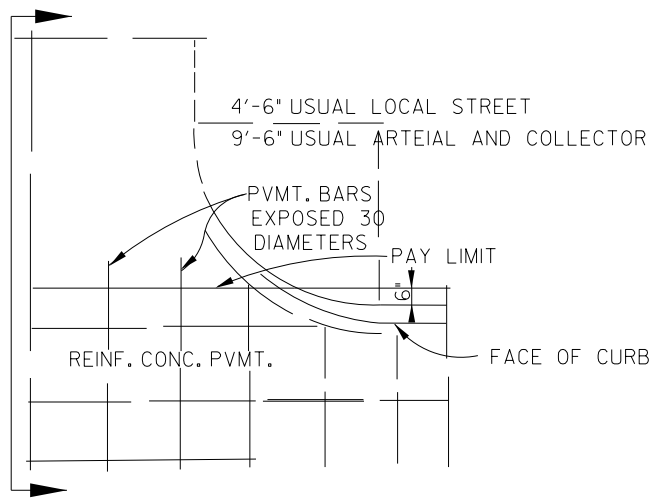

HALF PLAN REINF. CONC. PVMT. WITH INTEGRAL CONC. CURB

DRIVEWAYS ON ARTERIAL STREETS SHALL HAVE 10' FACE OF CURB RADII.

SCALE: NOT TO SCALE



MARBLE FALLS
800 THIRD STREET
MARBLE FALLS, TX 78654
PH: (830) 693-6737

These documents were prepared by,
or under the supervision of:

ERIC BELAJ 107148 May 31, 2017
Engineer's Name PE# Date

Engineer's Signature

SECTION

PAVING

DETAIL NO.

PV-13

TITLE

CURVED DRIVEWAY
REINFORCING PLAN

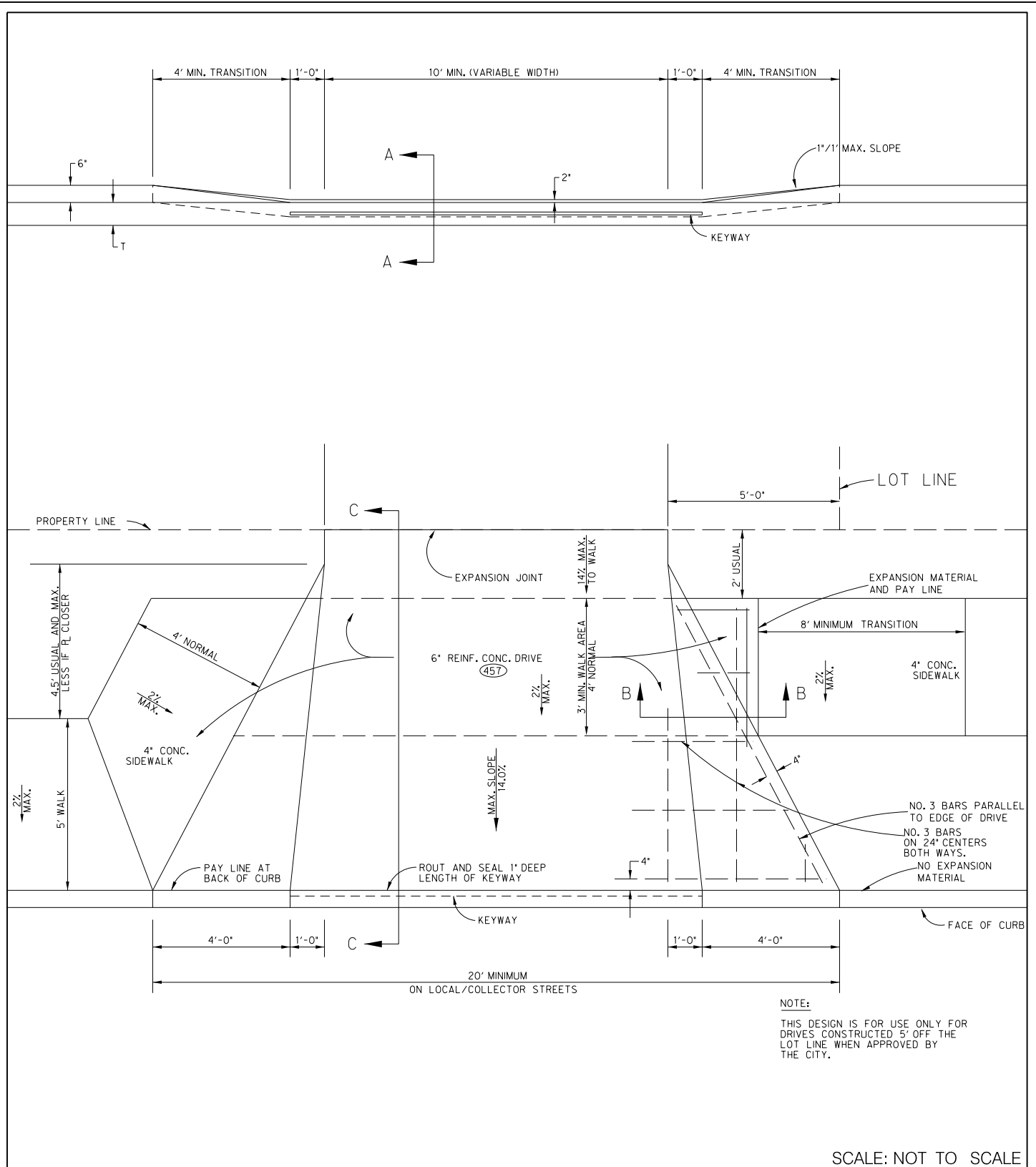

SCALE: NOT TO SCALE



MARBLE FALLS
800 THIRD STREET
MARBLE FALLS, TX 78654
PH: (830) 693-6737

These documents were prepared by,
or under the supervision of:

ERIC BELAJ 107148 May 31, 2017
Engineer's Name PE# Date

[Signature]
Engineer's Signature

SECTION

PAVING

DETAIL NO.

PV-14

TITLE

FLARED DRIVEWAY
REINFORCING PLAN

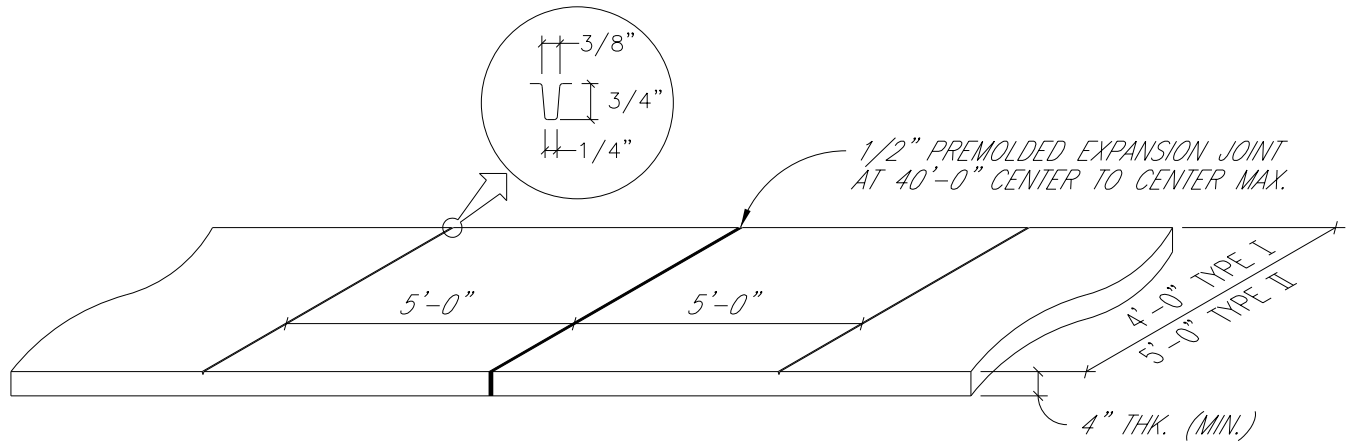

TYPE I – AS REQUIRED FOR SINGLE FAMILY, DUPLEXES AND TOWNHOUSES.

TYPE II – AS REQUIRED FOR APARTMENTS, OFFICE AND PARKING LOTS, COMMERCIAL AND INDUSTRIAL.

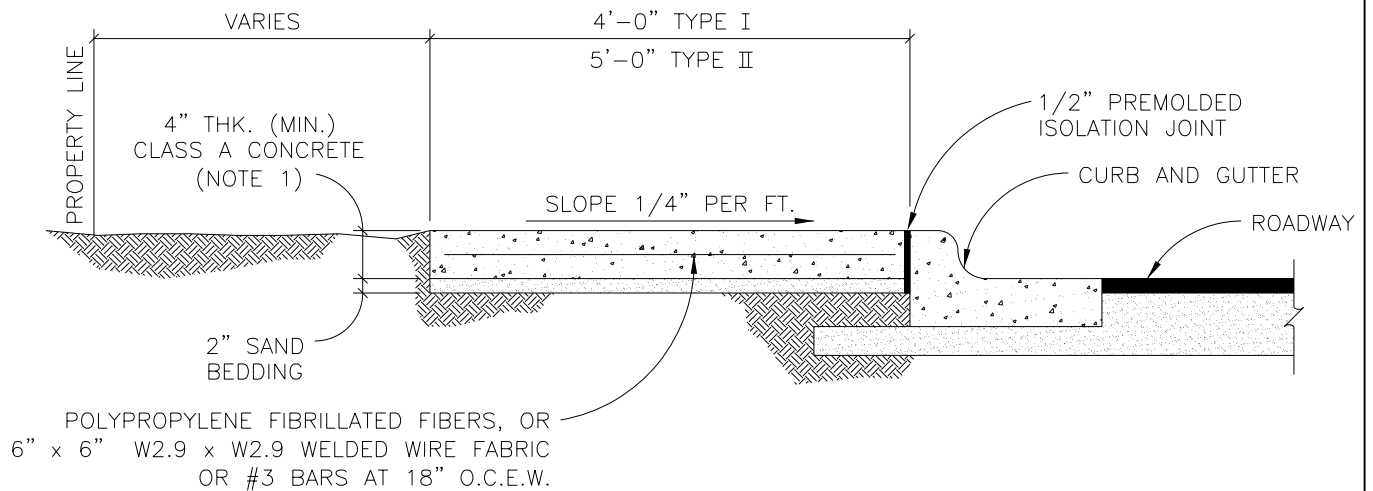

NOTES:

1. FOR ROLLER STAMPED SIDEWALK: 4000 P.S.I. CONCRETE WITH 3/8" AGGREGATE.
2. STANDARD LOCATION OF SIDEWALK IS OFF BACK OF CURB. SPECIAL DESIGNS MAY BE APPROVED BY THE CITY ENGINEER, PRIOR TO FINAL DESIGN.

SCALE: NOT TO SCALE



MARBLE FALLS
800 THIRD STREET
MARBLE FALLS, TX 78654
PH: (830) 693-6737

These documents were prepared by,
or under the supervision of:

ERIC BELAJ 107148 May 31, 2017
Engineer's Name PE# Date

Engineer's Signature

SECTION

PAVING

DETAIL NO.

PV-15

TITLE

TYPICAL SIDEWALK
SECTION

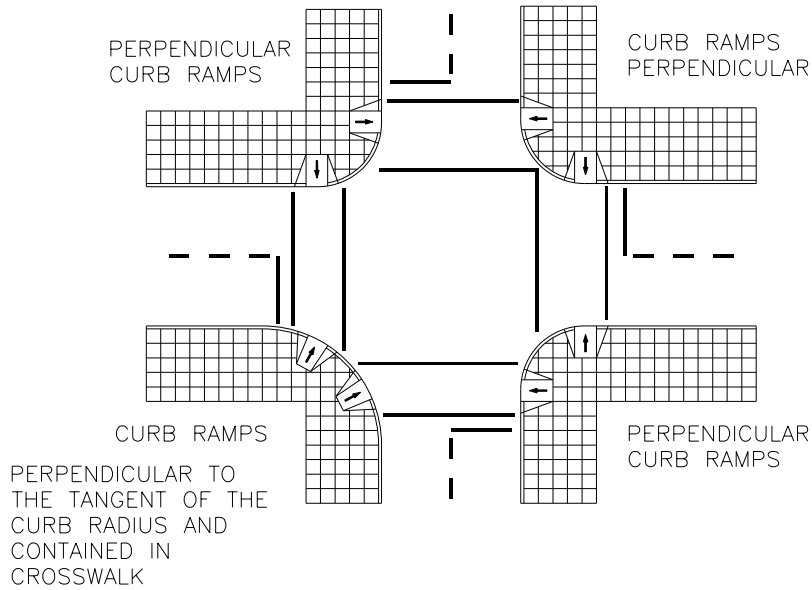

TYPICAL CURB RAMP PLACEMENTS AT INTERSECTIONS

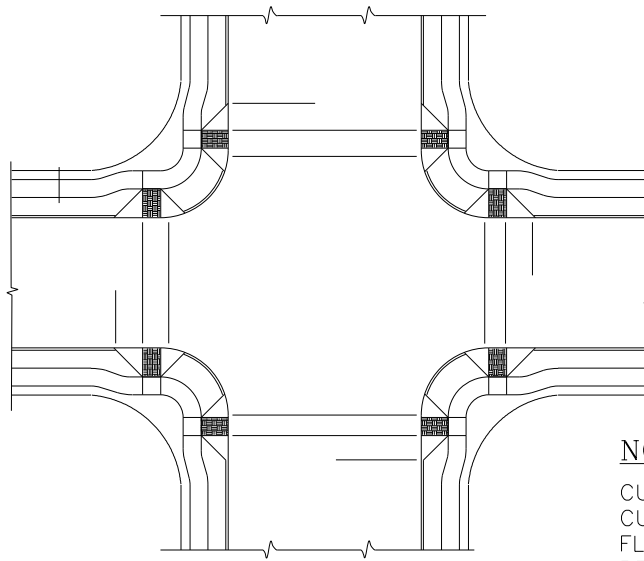

NOTE:

CURB RAMPS WITH RETURNED CURBS INSTEAD OF SIDE FLARES ARE PERMITTED WHERE PEDESTRIANS WOULD NOT NORMALLY WALK ACROSS THE RAMP.

TYPICAL INTERSECTION LAYOUT WITH OFFSET SIDEWALKS

SCALE: NOT TO SCALE



MARBLE FALLS
 800 THIRD STREET
 MARBLE FALLS, TX 78654
 PH: (830) 693-6737

These documents were prepared by,
 or under the supervision of:

ERIC BELAJ 107148 May 31, 2017
 Engineer's Name PE# Date

Engineer's Signature

SECTION

PAVING

DETAIL NO.

PV-16

TITLE

PERPENDICULAR RAMP
 LAYOUT (1 OF 2)

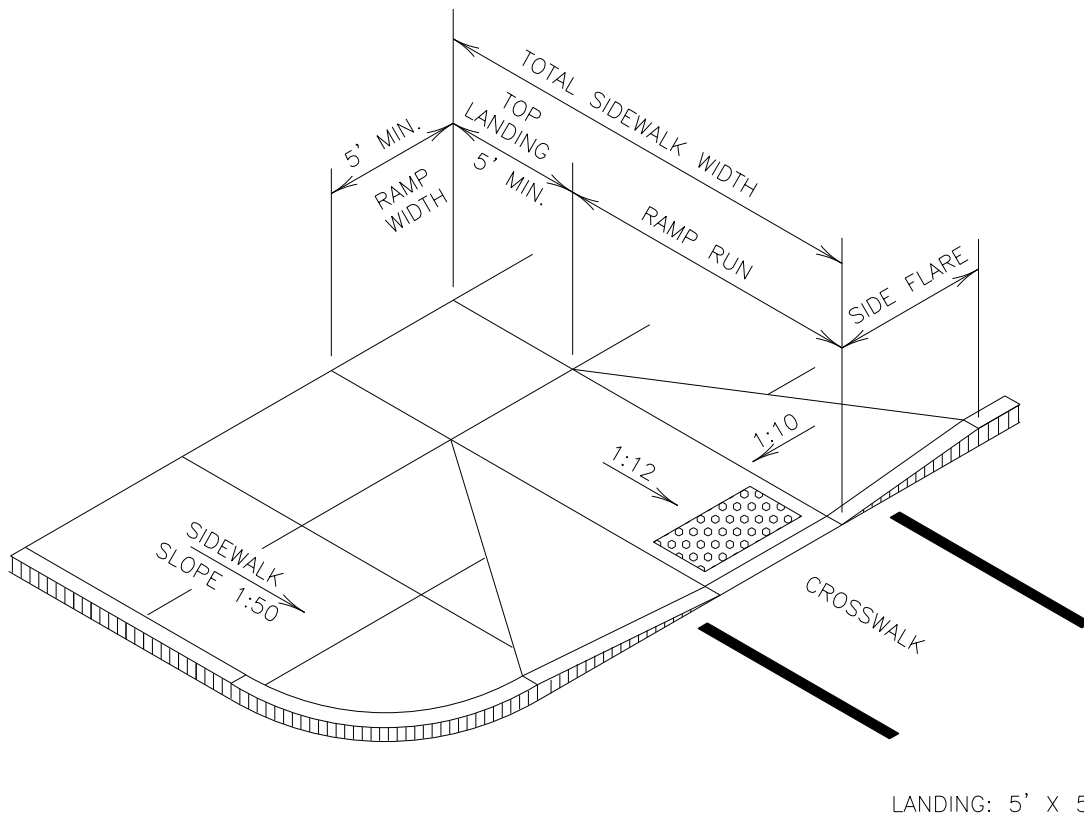

SCALE: NOT TO SCALE



MARBLE FALLS
 800 THIRD STREET
 MARBLE FALLS, TX 78654
 PH: (830) 693-6737

These documents were prepared by,
 or under the supervision of:

ERIC BELAJ 107148 May 31, 2017
 Engineer's Name PE# Date

Engineer's Signature

SECTION

PAVING

DETAIL NO.

PV-17

TITLE

PERPENDICULAR RAMP
 SECTION (2 OF 2)

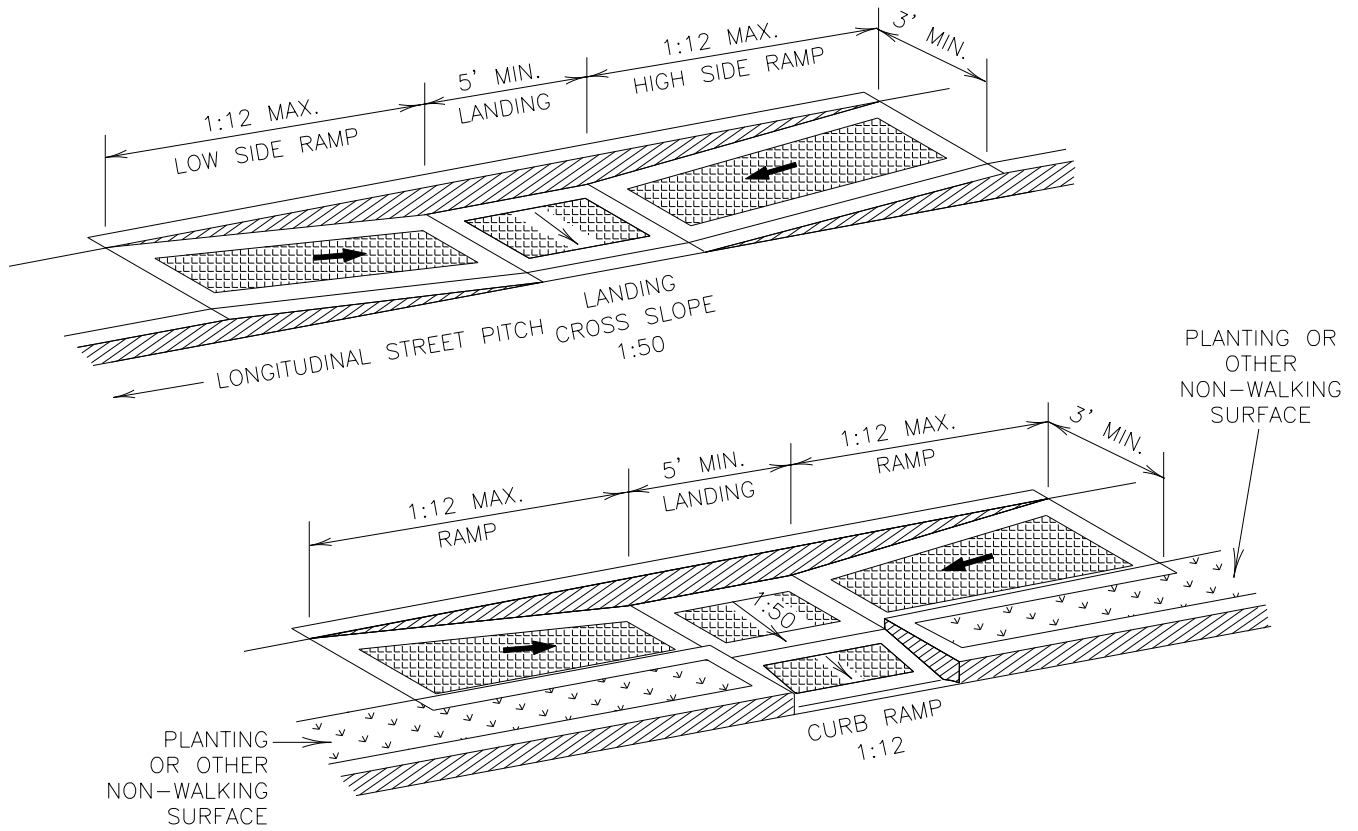

LANDING: 5' X 5'

SCALE: NOT TO SCALE



MARBLE FALLS
 800 THIRD STREET
 MARBLE FALLS, TX 78654
 PH: (830) 693-6737

These documents were prepared by,
 or under the supervision of:

ERIC BELAJ 107148 May 31, 2017
 Engineer's Name PE# Date

Engineer's Signature

SECTION

PAVING

DETAIL NO.

PV-18

TITLE

PARALLEL RAMP

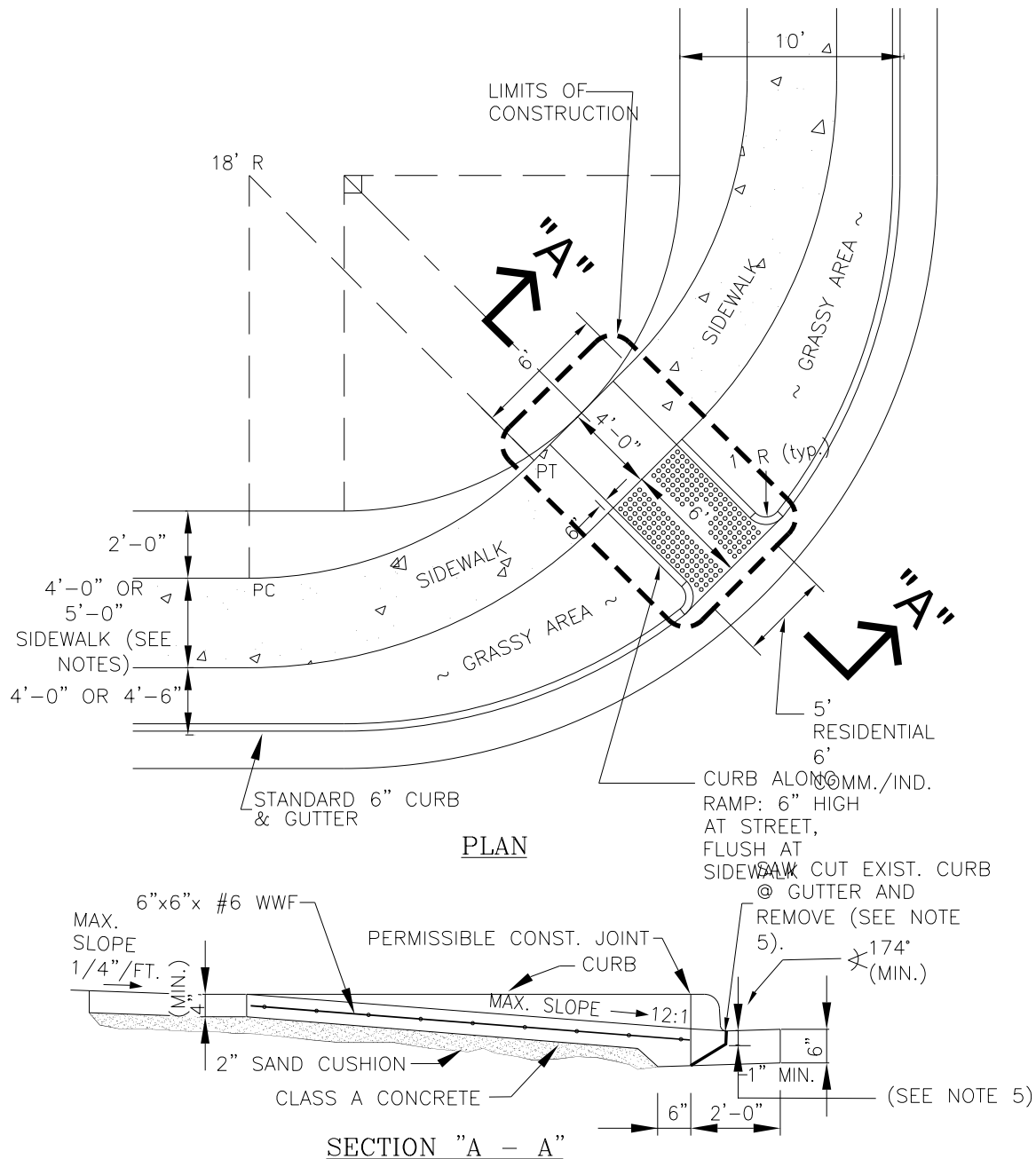

PLAN

SECTION "A - A"

GENERAL NOTES:

1. THIS ITEM WILL BE MEASURED BY SQUARE FOOT OF CONCRETE PLACED AND PAID FOR UNDER 4" CONCRETE SIDEWALK.
2. SIDEWALKS 4'-0" IN RESIDENTIAL AREAS, 5'-0" IN COMMERCIAL AREAS, AND 5'-0" WHEN ADJACENT TO CURB REGARDLESS OF ZONING.
3. THE RAMP SHALL HAVE A DETECTABLE WARNING AND CONTRASTING COLORED SURFACE. RAMP SHALL BE STAMPED AND DYED CONCRETE OR APPROVED EQUAL.
4. POSITION OF RAMP MAY BE ALTERED IN THE FIELD BY THE ENGINEER, BUT ONLY WITH PUBLIC WORKS DEPARTMENT APPROVAL.
5. SAW CUTTING APPLICABLE FOR INSTALLATION WHERE CURB LAYDOWN FOR RAMP NOT PROVIDED.

SCALE: NOT TO SCALE



MARBLE FALLS
800 THIRD STREET
MARBLE FALLS, TX 78654
PH: (830) 693-6737

These documents were prepared by,
or under the supervision of:

ERIC BELAJ 107148 May 31, 2017
Engineer's Name PE# Date

Engineer's Signature

SECTION	PAVING
DETAIL NO.	PV-19
TITLE	CORNER RAMP

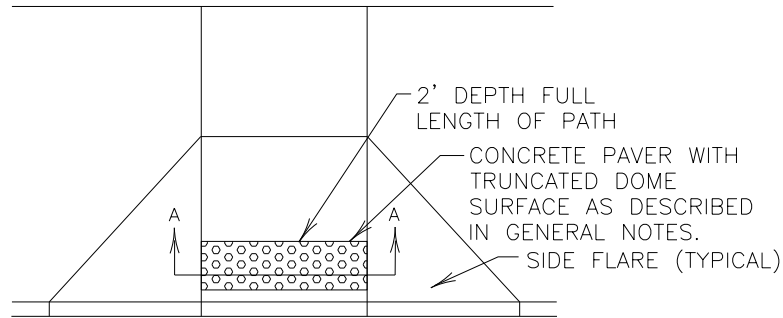

TYPE A

TRUNCATED DOME PATTERN CURB RAMP

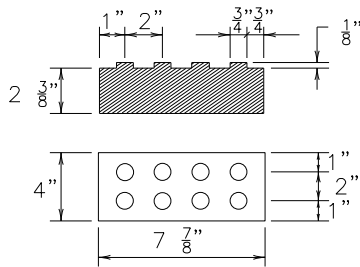

CONCRETE PAVER WITH TRUNCATED DOME SURFACE

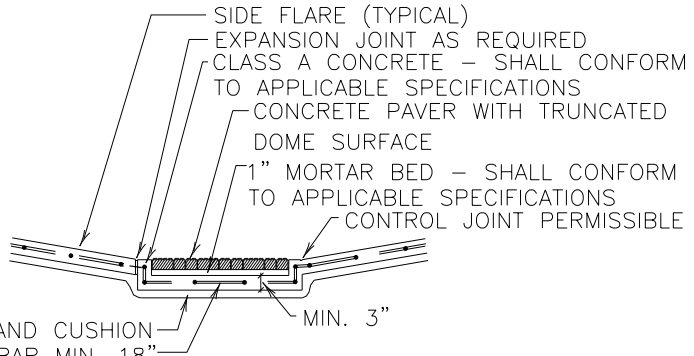

2" SAND CUSHION
NO. 3 REBAR MIN. 18"
ON-CENTER BOTH WAYS

SECTION A-A

CONCRETE PAVER NOTES:

CONCRETE PAVER UNITS SHALL MEET ALL REQUIREMENTS OF ASTM C-936, C-33, AND SHALL BE LAID IN A TWO BY TWO UNIT BASKET WEAVE PATTERN, UNLESS SHOWN OTHERWISE IN THE PLANS.

CONCRETE PAVER UNITS SHALL HAVE A TRUNCATED DOME TOP SURFACE FOR DETECTABLE WARNING TO PEDESTRIANS.

CONCRETE PAVER UNIT COLOR FOR THE RAMP SHALL BE A CONTRASTING COLOR TO THE ADJACENT SURFACES. THE COLOR OF THE CONCRETE PAVER UNITS SHALL BE SHOWN ELSEWHERE IN THE PLANS. (ADJACENT SURFACES INCLUDE SIDE FLARES).

CONCRETE PAVER UNITS SHALL BE SAW CUT ONLY AND ANY CUT UNIT SHALL BE NOT LESS THAN 25 PERCENT OF A FULL UNIT.

CURB RAMP NOTES:

CONCRETE SURFACE AREAS THAT ARE IDENTIFIED IN THE PLANS TO RECEIVE SEALER/STAIN TREATMENT, SHALL NOT BE TREATED W/ CURING COMPOUND (RETARDANT) AND SHALL BE ALLOWED TO CURE A MINIMUM OF 30 DAYS PRIOR TO APPLICATION OF THE SEALER/STAIN.

THE SEALER/STAIN FOR THE RAMP SHALL BE A CONTRASTING COLOR TO THE ADJACENT SURFACES (ADJACENT SURFACES INCLUDE THE SIDE FLARES). THE COLOR OF THE SEALER/STAIN SHALL BE SHOWN ELSEWHERE IN THE PLANS.

SEALER/STAIN SHALL BE APPLIED IN ACCORDANCE WITH APPLICABLE SPECIFICATIONS.

AREAS RECEIVING SEALER/STAIN TREATMENT SHALL BE CLEANED USING A "DRY" (SAND) BLAST CLEANING METHOD IN ACCORDANCE WITH APPLICABLE SPECIFICATIONS.

DETECTABLE WARNINGS SHALL CONSIST OF RAISED TRUNCATED DOMES WITH A DIAMETER OF NOMINAL 0.9 IN, A HEIGHT OF NOMINAL 0.2 IN AND A CENTER-TO-CENTER SPACING OF NOMINAL 2.35 IN AND SHALL CONTRAST VISUALLY WITH ADJOINING SURFACES, EITHER LIGHT-ON-DARK, OR DARK-ON-LIGHT.

SCALE: NOT TO SCALE



MARBLE FALLS

800 THIRD STREET
MARBLE FALLS, TX 78654

PH: (830) 693-6737

These documents were prepared by,
or under the supervision of:

ERIC BELAJ 107148 May 31, 2017
Engineer's Name PE# Date

Engineer's Signature

SECTION

PAVING

DETAIL NO.

PV-20

TITLE

RAMP TRUNCATED
DOME TEXTURING

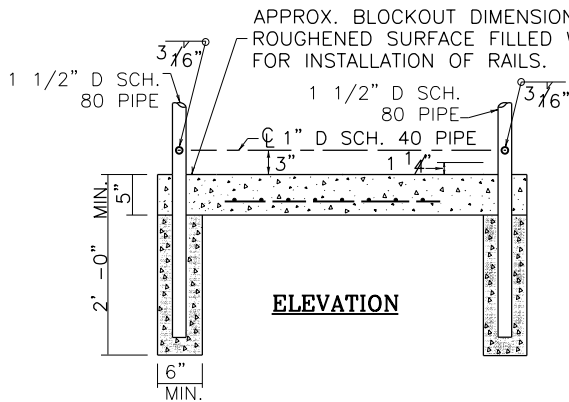

APPROX. BLOCKOUT DIMENSIONS AS SHOWN.
ROUGHENED SURFACE FILLED WITH GROUT
FOR INSTALLATION OF RAILS.

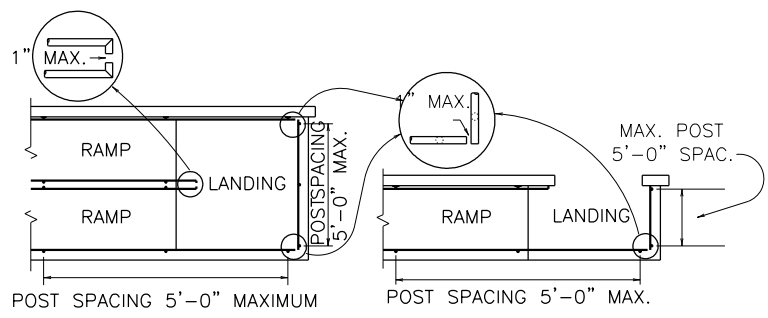

PLAN
MULTI-LEVEL RAMP **PLAN**
SINGLE-LEVEL RAMP

RAIL POSTS, MAY BE CAST INTO SIDEWALK OR
ANCHORED IN BLOCKOUT AFTER SIDEWALK
CONCRETE HAS CURED.

OPTIONAL RAIL POST WITHOUT CURB

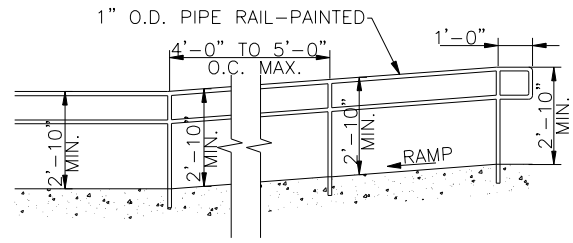

FLOOR MOUNTED

HANDRAIL TERMINATION AT RAMP-TYP.
(BOTH SIDES OF STEPS)

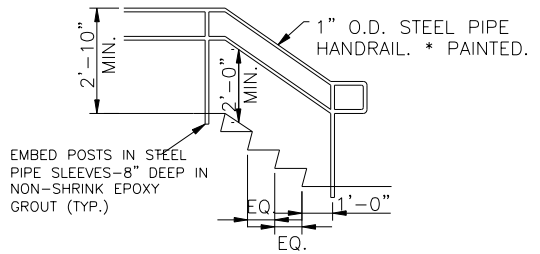

STAIR HANDRAIL

(BOTH SIDES OF STEPS)

GENERAL NOTES:

DESIGN CONFORMS TO TEXAS ACCESSIBILITY STANDARDS AND AASHTO 1993 STANDARD AND CURRENT INTERIM SPECIFICATIONS.

SEE SIDEWALK AND RAMP DETAILS FOR (*) RAMP SLOPE, DIMENSIONS AND FOR TYPICAL CONCRETE AND REINFORCING STEEL. THIS SHEET SHOWS ADDITIONAL REINFORCING STEEL REQUIRED FOR HANDRAIL.

MATERIAL FOR POSTS AND HANDRAILS SHALL BE ASTM A53 GR B, OR A501. BASE PLATES SHALL BE A36. ALL PARTS SHALL BE GALVANIZED IN ACCORDANCE WITH THE SPECIFICATIONS.

SQUARE TUBING OF EQUIVALENT OUTSIDE DIMENSIONS AND STRENGTH MAY BE SUBSTITUTED FOR THE ROUND SHAPES SHOWN AS DIRECTED BY THE ENGINEER.

ANCHOR BOLTS FOR HANDRAILS ATTACHED TO THE WALL SHALL BE PLACED USING AN ADHESIVE DOWELING SYSTEM APPROVED BY THE ENGINEER. ANCHOR BOLTS SHALL HAVE AN ALLOWABLE CAPACITY OF 2400 LBS IN TENSION AND 2300 LBS IN SHEAR. INSTALLATION OF THE ANCHOR BOLTS, INCLUDING HOLE DEPTH AND DIAMETER, SHALL BE IN ACCORDANCE WITH THE MANUFACTURERS' RECOMMENDATION. IF REQUIRED BY THE ENGINEER, 3 OF THE FIRST 10 ANCHORS, AND 5% OF THE REMAINING ANCHORS SHALL BE TESTED TO 70% OF MINIMUM SPECIFIED YIELD. THE CONTRACTOR SHALL PROVIDE A SUITABLE RAM, PUMP, PRESSURE GAUGE AND REACTION SYSTEM.

ANCHOR BOLTS FOR POSTS ATTACHED ON THE RAMP SHALL CONFORM TO ASTM A36 OR APPROVED EQUAL. NUTS FOR ANCHOR BOLTS SHALL CONFORM TO ASTM A563 GR A OR BETTER HEAVY HEX. THREADS FOR ANCHOR BOLTS AND NUTS SHALL BE ROLLED OR CUT THREADS OF UNIFIED NATIONAL COARSE (UNC) THREAD SERIES. BOLTS AND NUTS SHALL HAVE CLASS 2A AND 2B FIT TOLERANCES. ANCHOR BOLTS AND EXPOSED NUTS SHALL BE GALVANIZED OR COATED WITH ZINC-RICH PAINT. WASHERS SHALL BE GALVANIZED. ANCHOR BOLTS IN RAMP AND SIDEWALK MAY BE ANCHORED USING A DRILL AND GROUT SYSTEM.

EXPOSED EDGES OF HANDRAIL AND HANDRAIL POSTS SHALL BE ROUNDED OR CHAMFERED TO APPROXIMATELY 1/8 INCH BY GRINDING.

ANCHOR BOLTS, NUTS AND WASHERS TO BE INCLUDED IN UNIT PRICE BID FOR RAILING.

ERECTION DRAWINGS SHOWING PANEL LENGTHS, SPLICE LOCATIONS, RAIL POST SPACING AND ANCHOR BOLTS SETTING SHALL BE SUBMITTED TO THE ENGINEER FOR APPROVAL.

RAIL MAY BE ASSEMBLED (WELDED) IN THE FIELD.

PIPE SHALL BE GALVANIZED, OR PRIMED, AND PAINTED AS DIRECTED BY THE ENGINEER.

SCALE: NOT TO SCALE



MARBLE FALLS
800 THIRD STREET
MARBLE FALLS, TX 78654
PH: (830) 693-6737

These documents were prepared by,
or under the supervision of:

ERIC BELAJ 107148 May 31, 2017
Engineer's Name PE# Date



Engineer's Signature

SECTION	PAVING
DETAIL NO.	PV-22
TITLE	RAMP HANDRAIL (2 OF 2)

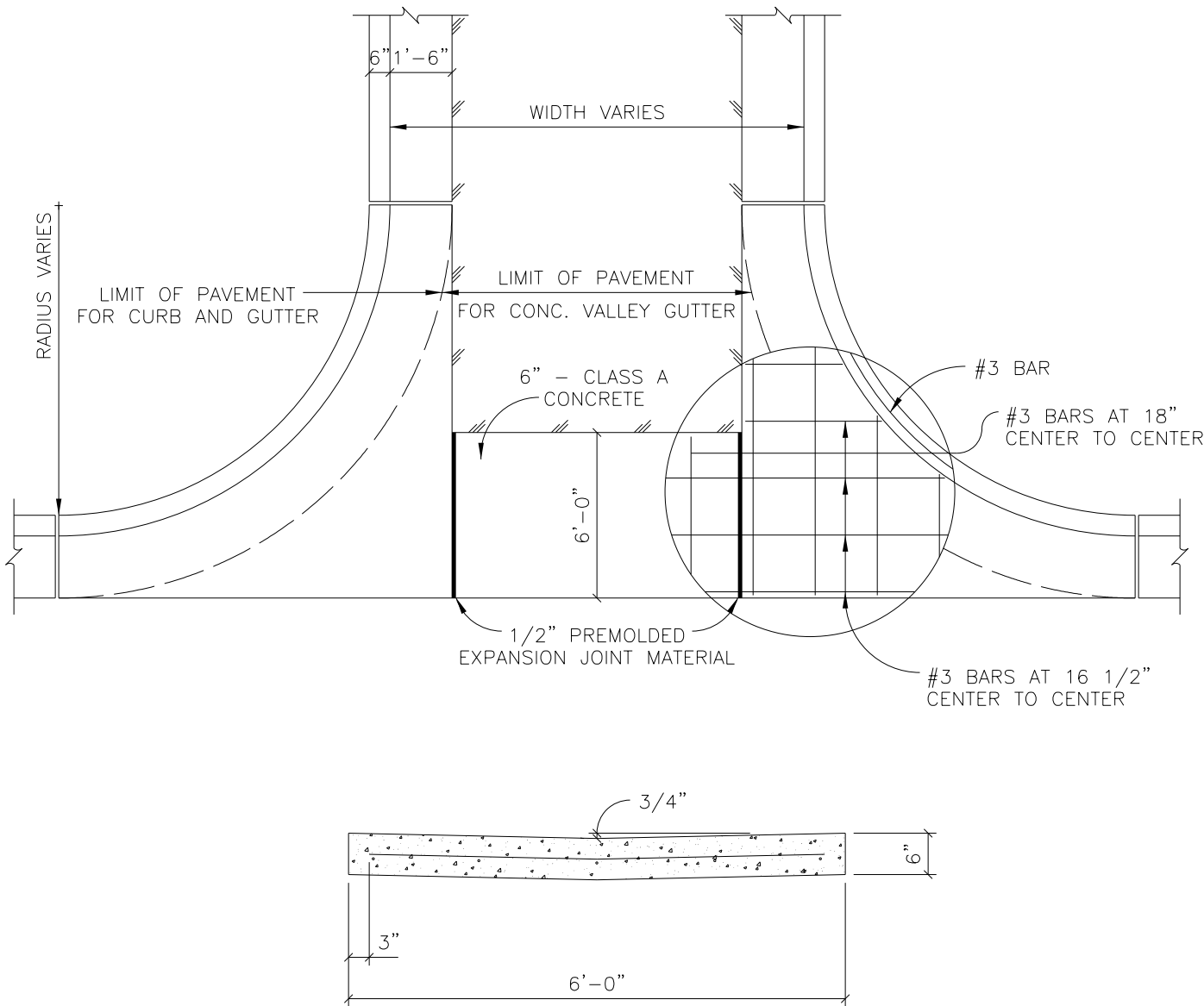

SCALE: NOT TO SCALE



MARBLE FALLS
 800 THIRD STREET
 MARBLE FALLS, TX 78654
 PH: (830) 693-6737

These documents were prepared by,
 or under the supervision of:

ERIC BELAJ 107148 May 31, 2017
 Engineer's Name PE# Date

Engineer's Signature

SECTION

PAVING

DETAIL NO.

PV-23

TITLE

VALLEY GUTTER

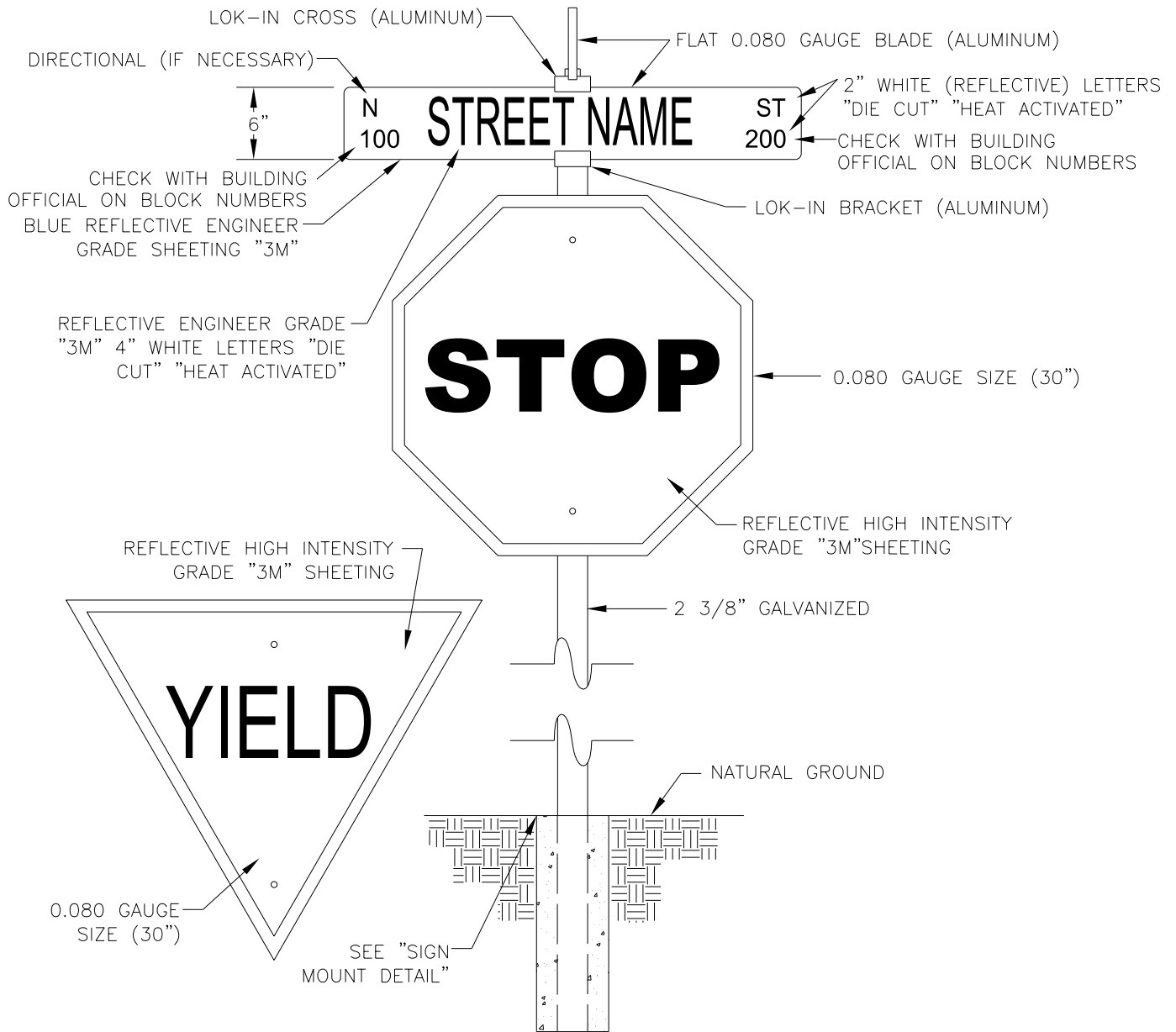

NOTE:

1. 7-FOOT MIN. HEIGHT FROM GROUND TO BOTTOM OF LOWEST SIGN

NOTE:

STREET NAME BACKGROUND COLOR SHOULD BE ROYAL BLUE

SCALE: NOT TO SCALE



MARBLE FALLS
 800 THIRD STREET
 MARBLE FALLS, TX 78654
 PH: (830) 693-6737

These documents were prepared by,
 or under the supervision of:

ERIC BELAJ 107148 May 31, 2017
 Engineer's Name PE# Date

Engineer's Signature

SECTION

PAVING

DETAIL NO.

PV-24

TITLE

SIGN MOUNT
 (1 OF 2)

SWAGED CHAMFER
BOTH ENDS

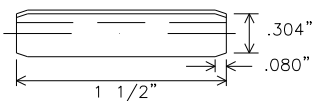

TEXAS UNIVERSAL TRIANGULAR SLIPBASE SYSTEM

POST
10 BWG TUBING OR
SCHEDULE 80 PIPE

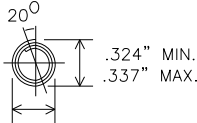

.324" MIN.
.337" MAX.

DOUBLE ROLL PIN DETAIL

5/8" STRUCTURAL BOLTS
(3), NUTS (3), AND
WASHERS (6) PER ASTM
A325 OR A449 AND
GALVANIZED PER TXDOT
ITEM 445 "GALVANIZING."
BOLT LENGTH IS 2 1/2"
FOR NEW INSTALLATION
AND 4" IF LIFTING
SPACER IS USED.

BOLT
KEEPER PLATE

SLIP BASE
CASTING

LOCKING COLLAR
SEE DETAIL "E"

LIFTING SPACER
(USED ONLY WHEN
RETROFITTING OLD
SYSTEM STUB
WITH LIFTING
RAMP)

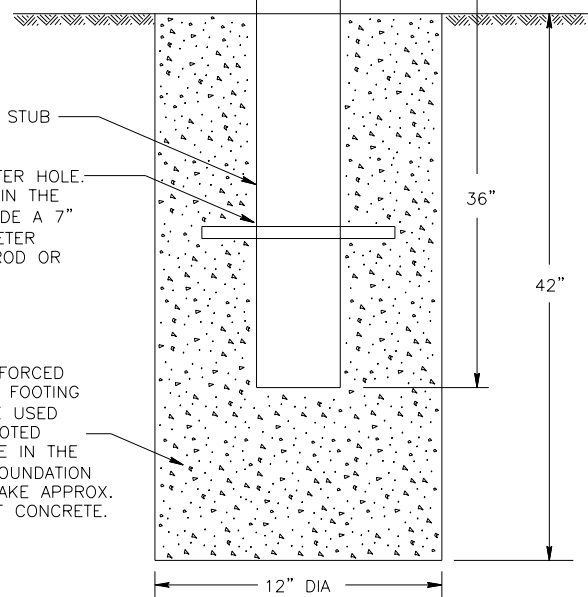

3/4" DIAMETER HOLE.
IF REQUIRED IN THE
PLANS, PROVIDE A 7"
X 1/2" DIAMETER
GALVANIZED ROD OR
#4 REBAR.

NON-REINFORCED
CONCRETE FOOTING
(SHALL BE USED
UNLESS NOTED
ELSEWHERE IN THE
PLANS). FOUNDATION
SHOULD TAKE APPROX.
2.5 CF OF CONCRETE.

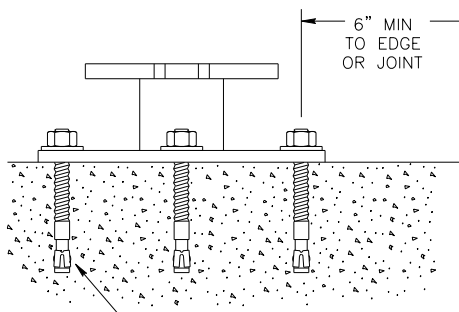

5/8" DIAMETER CONCRETE ANCHOR -
8 PLACES (EMBED A MINIMUM OF 5
1/2" AND TORQUE TO MIN. OF 50
FT-LBS). ANCHOR MAY BE
EXPANSION OR ADHESIVE TYPE.

DETAIL E

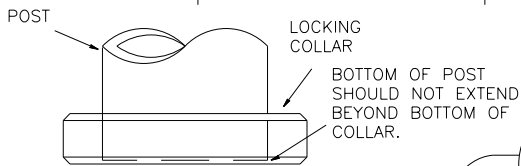

ROLL PIN
(OPTIONAL)

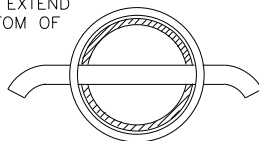

VIEW G-G

NOTE:

WHEN THIN WALL TUBING IS USED,
RUBBER INSERT MUST BE PLACED IN BASE
POST.

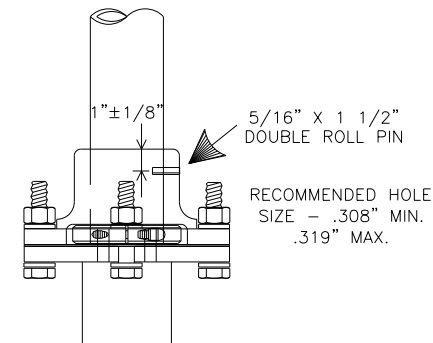

IF SHOWN IN PLANS, THE ENGINEER MAY
REQUIRE THE ROLL PIN TO BE INSTALLED
TO REDUCE POSSIBLE SIGN ROTATION.

SCALE: NOT TO SCALE



MARBLE FALLS
800 THIRD STREET
MARBLE FALLS, TX 78654
PH: (830) 693-6737

These documents were prepared by,
or under the supervision of:

ERIC BELAJ 107148 May 31, 2017
Engineer's Name PE# Date

Engineer's Signature

SECTION

PAVING

DETAIL NO.

PV-25

TITLE

SIGN MOUNT
(2 OF 2)

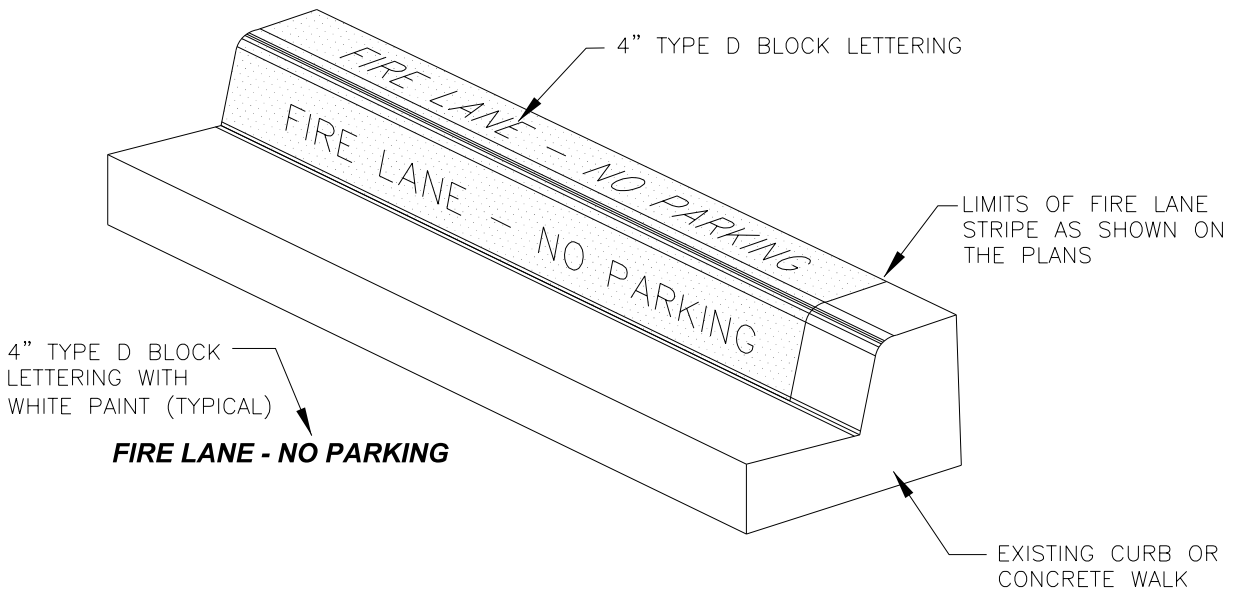

APPLICATION:

1. ON EXISTING 6" CURB: PAINT RED LANE STRIPE ON BOTH FACE AND TOP OF CURB PAINT WHITE LETTERS ON FACE OF CURB ONLY.
2. LOW CURB (HEADER CURB): PAINT RED LANE STRIPE AND WHITE LETTERS ON TOP OF CURB.
3. ASPHALT : PAINT RED LANE STRIPE AND WHITE LETTERS TO THE LIMITS AS INDICATED ON THE PLANS.
4. 50 FEET SPACING BETWEEN THE BEGINNING OF THE WHITE LETTERING.

NOTE:

1. FIRE LANE STRIPING ALONG CURBS ONLY. PROVIDE "FIRE LANE - NO PARKING" SIGNS ALONG FIRE LANE

SCALE: NOT TO SCALE



MARBLE FALLS
 800 THIRD STREET
 MARBLE FALLS, TX 78654
 PH: (830) 693-6737

These documents were prepared by,
 or under the supervision of:

ERIC BELAJ 107148 May 31, 2017
 Engineer's Name PE# Date

Engineer's Signature

SECTION

PAVING

DETAIL NO.

PV-26

TITLE

FIRE LANE STRIPING
 (1 OF 2)

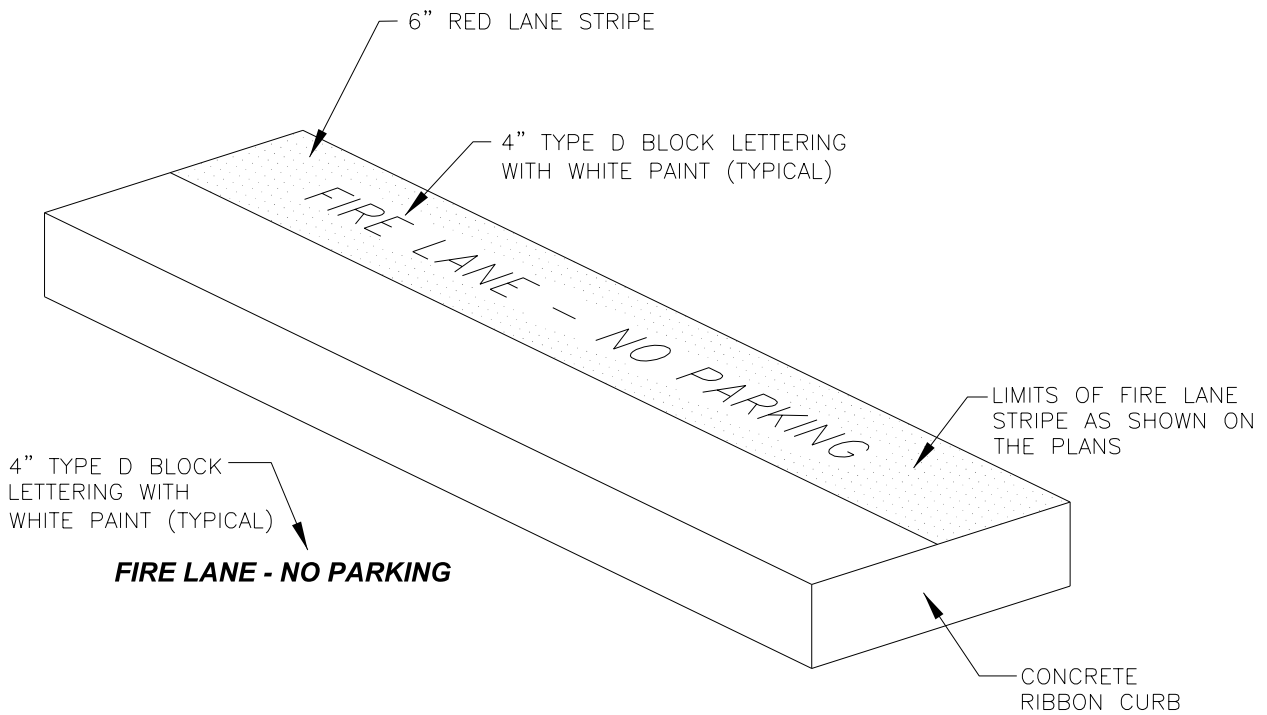

APPLICATION:

1. ON PROPOSED 18" RIBBON CURB: PAINT 6" RED LANE STRIPE ON TOP OF CURB PAINT WHITE LETTERS ON TOP OF CURB.
2. ASPHALT : PAINT RED LANE STRIPE AND WHITE LETTERS TO THE LIMITS AS INDICATED ON THE PLANS.
3. 50 FEET SPACING BETWEEN THE BEGINNING OF THE WHITE LETTERING.

NOTE:

1. FIRE LANE STRIPING ALONG CURBS ONLY. PROVIDE "FIRE LANE - NO PARKING" SIGNS ALONG FIRE LANE

SCALE: NOT TO SCALE



MARBLE FALLS
 800 THIRD STREET
 MARBLE FALLS, TX 78654
 PH: (830) 693-6737

These documents were prepared by,
 or under the supervision of:

ERIC BELAJ 107148 May 31, 2017
 Engineer's Name PE# Date

Engineer's Signature

SECTION

PAVING

DETAIL NO.

PV-27

TITLE

FIRE LANE STRIPING
 (2 OF 2)

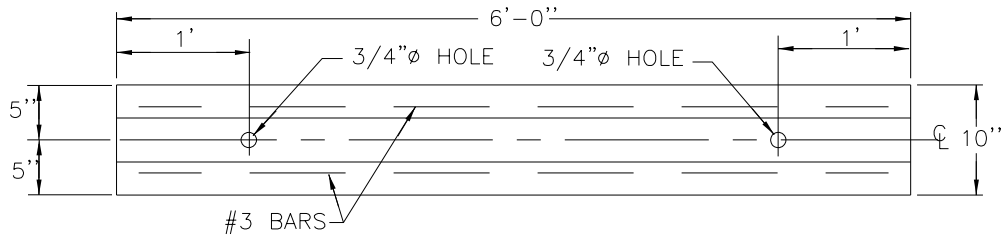

PLAN

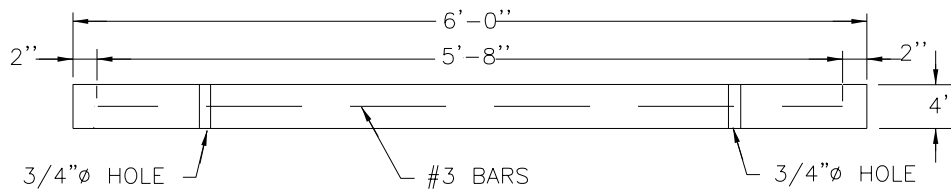

LONGITUDINAL SECTION

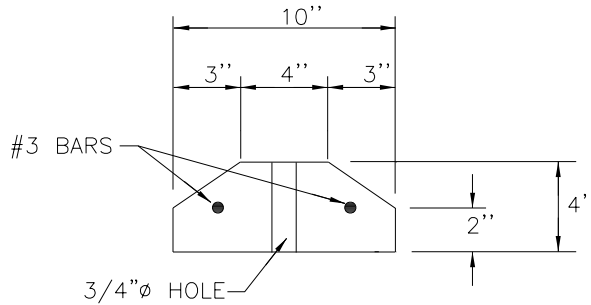

ALL CONCRETE SHALL BE CLASS "A"
IN ACCORDANCE WITH ITEM 403.

CROSS SECTION

SCALE: NOT TO SCALE



MARBLE FALLS
800 THIRD STREET
MARBLE FALLS, TX 78654
PH: (830) 693-6737

These documents were prepared by,
or under the supervision of:

ERIC BELAJ 107148 May 31, 2017
Engineer's Name PE# Date

[Signature]
Engineer's Signature

SECTION

PAVING

DETAIL NO.

PV-28

TITLE

WHEEL STOP

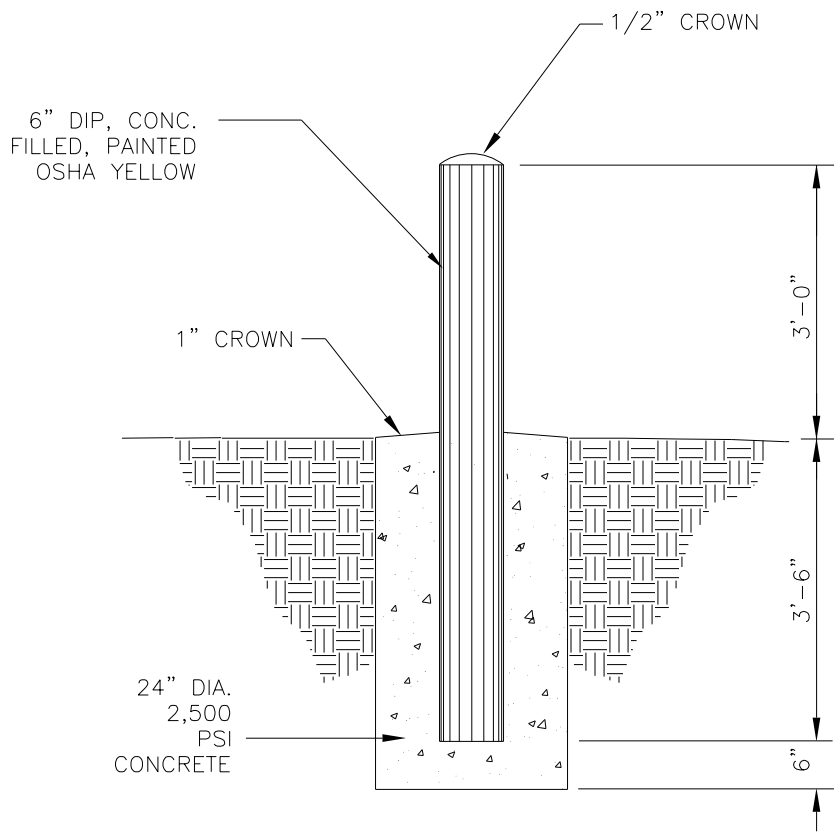

SCALE: NOT TO SCALE



MARBLE FALLS
 800 THIRD STREET
 MARBLE FALLS, TX 78654
 PH: (830) 693-6737

These documents were prepared by,
 or under the supervision of:

ERIC BELAJ 107148 May 31, 2017
 Engineer's Name PE# Date

Engineer's Signature

SECTION

PAVING

DETAIL NO.

PV-29

TITLE

BOLLARD

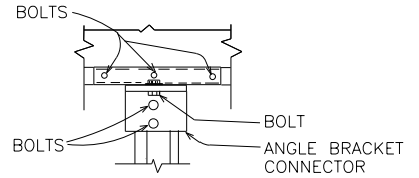
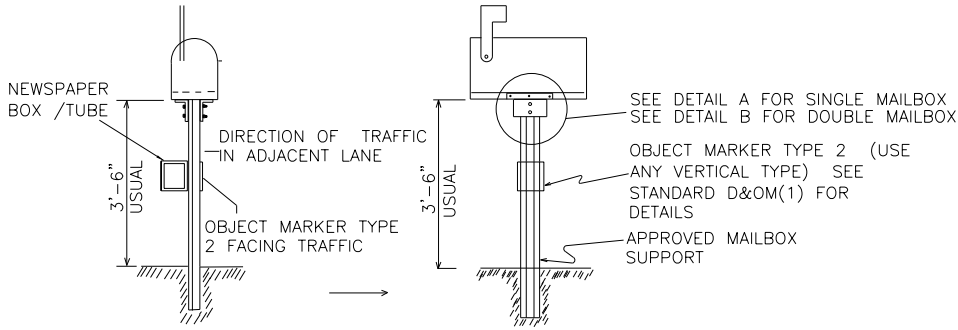

FOR BOLT SIZES SEE NOTES FOR STANDARD MAILBOX ATTACHMENT DETAILS

DETAIL A
SINGLE MAILBOX MOUNT

SINGLE MAILBOX – STANDARD MOUNT

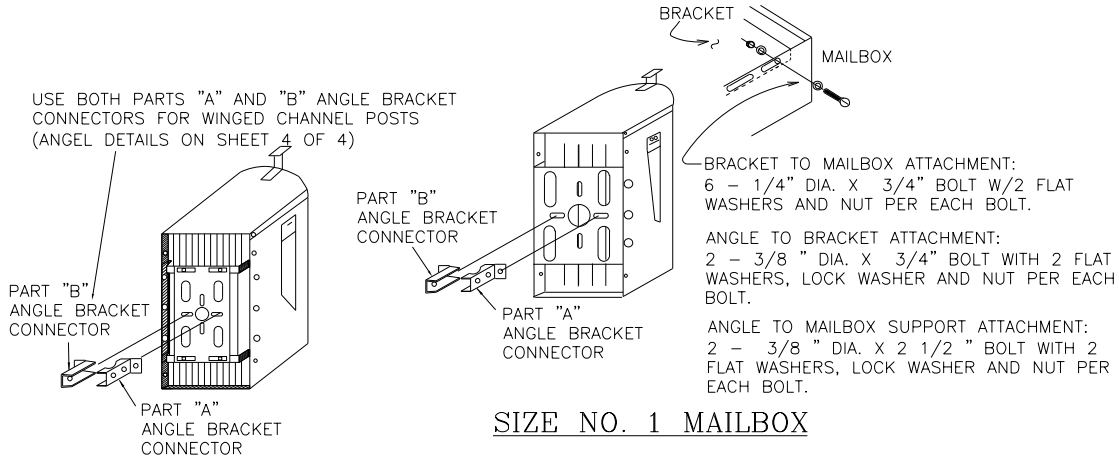

SIZE NO. 1 MAILBOX

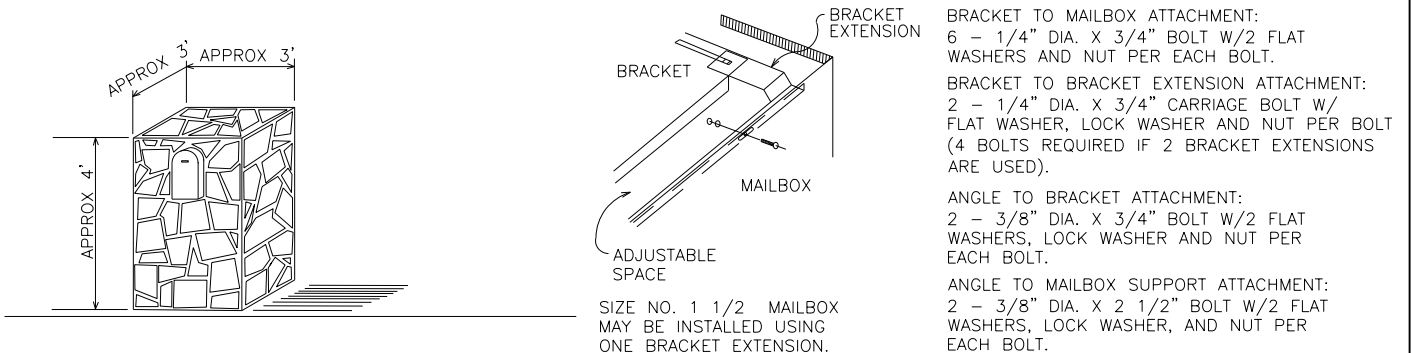

MAILBOX – MASONRY TYPE

SIZE NO. 1 1/2 AND NO. 2 MAILBOX

PRIOR TO BIDDING, THE CONTRACTOR SHALL REVIEW THE MASONRY TYPE MAILBOXES ON THE PROJECT. THE METHOD OF CONSTRUCTION AND MATERIALS FOR THE NEW MAILBOXES SHALL BE SIMILAR TO EXISTING STRUCTURES.

REMOVAL AND DISPOSAL OF WASTE MATERIAL SHALL BE CONSIDERED SUBSIDIARY TO THIS PAY ITEM.

SCALE: NOT TO SCALE



MARBLE FALLS
800 THIRD STREET
MARBLE FALLS, TX 78654
PH: (830) 693-6737

These documents were prepared by,
or under the supervision of:

ERIC BELAJ 107148 May 31, 2017
Engineer's Name PE# Date

Engineer's Signature

SECTION

PAVING

DETAIL NO.

PV-30

TITLE

MAILBOX

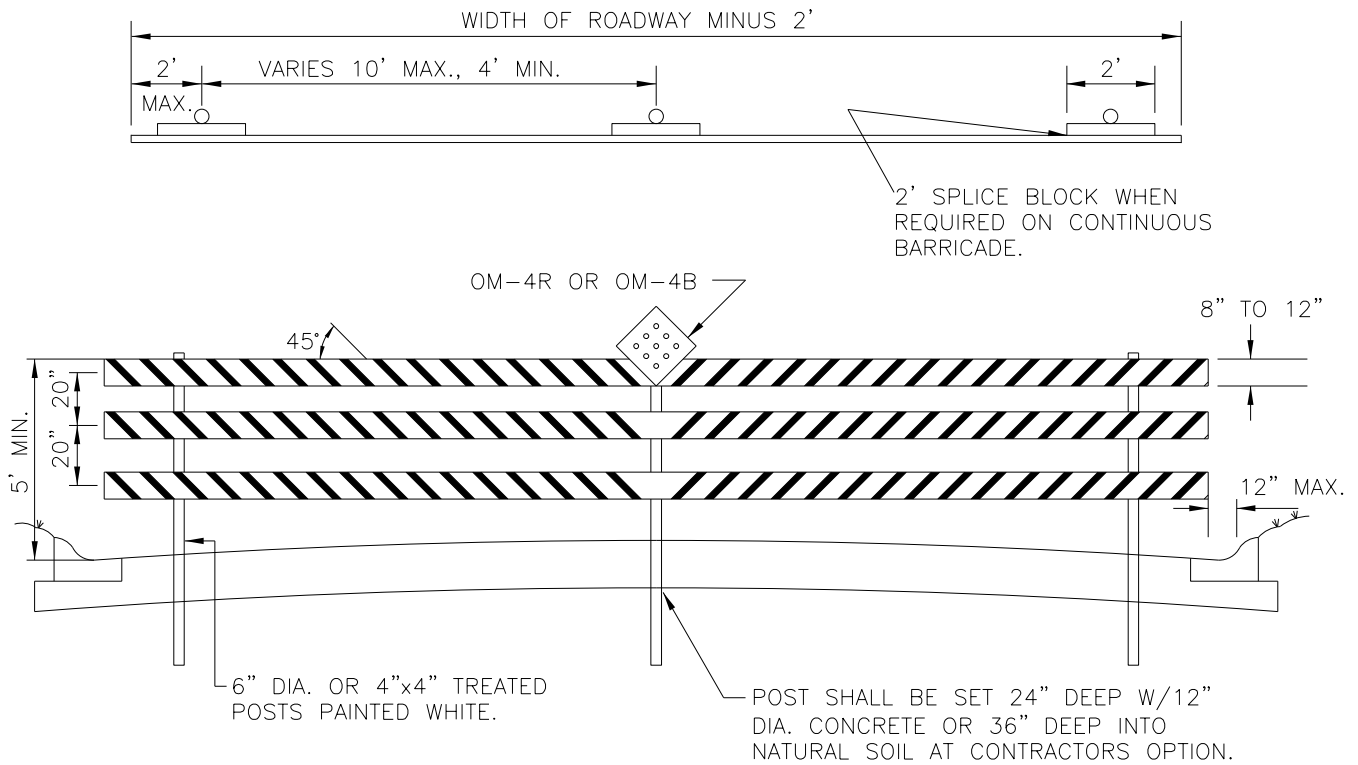

NOTES:

1. THE DESIGN OF THIS BARRICADE IS IN COMPLIANCE WITH THE TEXAS MANUAL ON UNIFORM TRAFFIC CONTROL DEVICES FOR STREETS AND HIGHWAYS.
2. WIDTH OF RAIL SHALL BE A MINIMUM OF 8" AND MAY BE UP TO A MAXIMUM OF 12", 2" NOMINAL SMOOTH LUMBER.
3. RAILS SHALL BE FASTENED TO EACH POST WITH 1/4" STEEL BOLTS WITH WASHERS ON EACH SIDE OR WITH 3-20d NAILS.
4. THE RAILS SHALL RECEIVE TWO COATS OF WHITE OIL BASE OUTSIDE PAINT, THEN SHALL HAVE 6" WIDE REFLECTORIZED RED STRIPES OF TAPE PLACED ON 45° SLOPES, DOWN AND TOWARD THE CENTER OF THE BARRICADE.
5. BARRICADES MAY BE CONSTRUCTED IN SECTIONS OR MAY BE CONTINUOUS ACROSS ROADWAY WIDTH. SPLICES ON CONTINUOUS RAIL BARRICADES SHALL BE AT POSTS AND SHALL HAVE A 2' SPLICE BLOCK ON BACK SIDE OF THE SAME MATERIAL AS RAIL.
6. 18" DIAMOND REFLECTORIZED RED PANEL OR 18" DIAMOND RED OR BLACK PANEL WITH 9-3" DIAMETER RED REFLECTORS SYMMETRICALLY PLACED AT CENTER POSTS, A MINIMUM OF 4' ABOVE GROUND SHALL BE USED FOR END OF ROAD MARKERS.

SCALE: NOT TO SCALE



MARBLE FALLS
800 THIRD STREET
MARBLE FALLS, TX 78654
PH: (830) 693-6737

These documents were prepared by,
or under the supervision of:

ERIC BELAJ 107148 May 31, 2017
Engineer's Name PE# Date

Engineer's Signature

SECTION

PAVING

DETAIL NO.

PV-31

TITLE

BARRICADE

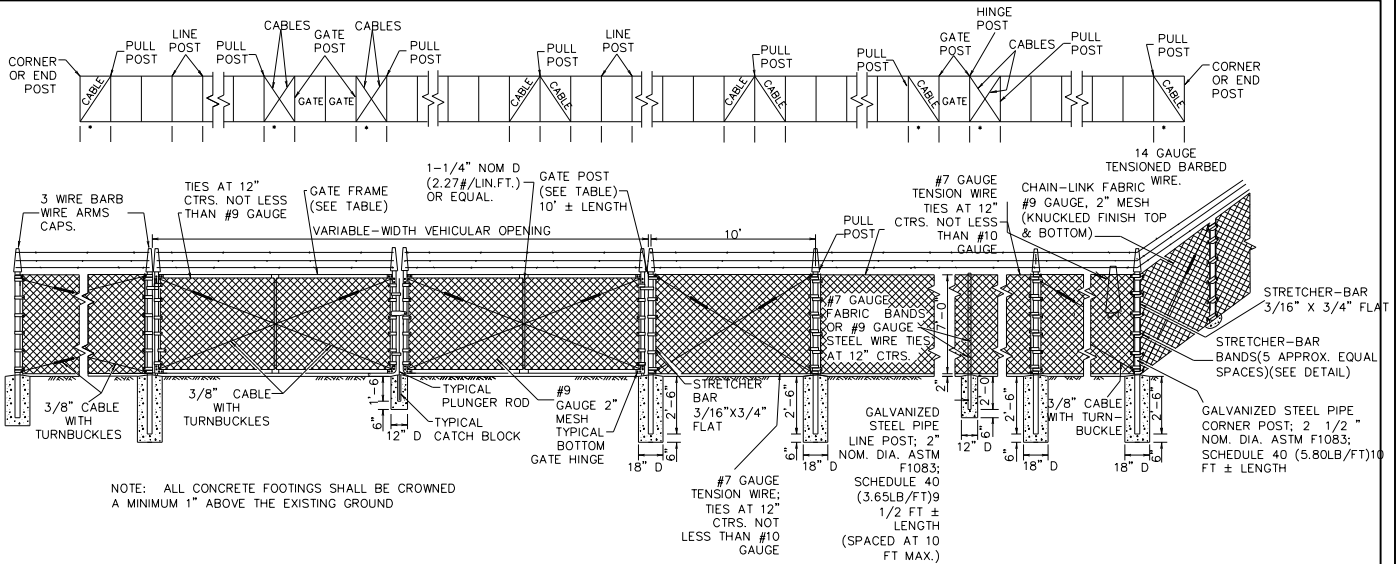

CHAIN-LINK BARRIER FENCE (6 FT.)

** THICKNESS EQUAL TO THICKNESS OF GATE FRAME, OR GREATER

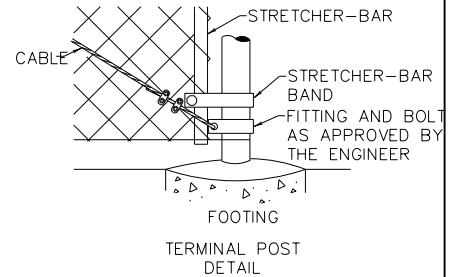
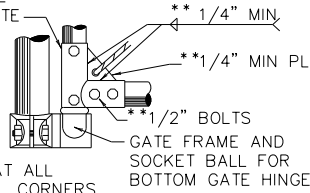

R = RADIUS
D = DIAMETER

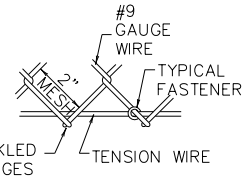

FABRIC & TENSION WIRE DETAIL TOP & BOTTOM

TABLE OF MINIMUM SIZES & WEIGHTS

GATE OPENING TYPE			
SINGLE INCLUSIVE		DOUBLE INCLUSIVE	
UP TO 6'		UP TO 12'	
OVER 6' TO 12'		OVER 12' TO 26'	
OVER 12' TO 18'		OVER 26' TO 36'	
OVER 18'		OVER 36'	
GATE FRAME		GATE POST	
SIZE	WT./LIN. FT.	SIZE	WT./LIN. FT.
1-1/2" NOM D	2.72 LBS.	2-1/2" NOM D	5.79 LBS.
OR EQUAL	2.72 LBS.	OR EQUAL	
	2.72 LBS.	3-1/2" NOM D	9.11 LBS.
		OR EQUAL	
		6" NOM D	18.97 LBS.
		8" NOM D	24.70 LBS.

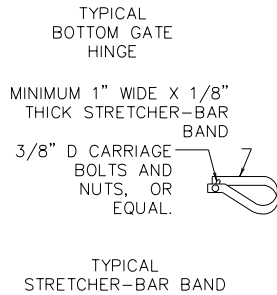

CHAIN-LINK BARRIER FENCE
6 FOOT HEIGHT SECURITY

GENERAL NOTES:

1. TYPICAL INSTALLATION PLAN MAY VARY AS SHOWN ELSEWHERE ON THE PLANS OR AS DIRECTED BY THE ENGINEER. LOCATION OF GATES SHOWN ELSEWHERE ON PLANS.
2. GATE-FRAME MEMBERS SHALL BE BOLTED, AT FRAME CORNERS, TO JOINT FITTINGS WITH FOUR 1/2" BOLTS PER JOINT.
3. ALL CABLE CONNECTIONS ARE TO BE MADE WITH TWO 3/8" CABLE CLAMPS.
4. ALL PULL POSTS AND END POSTS AND THEIR FOUNDATIONS SHALL HAVE THE SAME RESPECTIVE DIMENSIONS AS THOSE SHOWN FOR CORNER POST.
5. ALL PULL POST SHALL BE FURNISHED WITH TWO STRETCHER BARS.
6. ONE END OF EACH TURNBUCKLE MAY BE ATTACHED DIRECTLY TO FITTINGS WITH A CLEVIS.
7. BARBED WIRE ARMS SHALL BE ACCORDING TO INDUSTRY STANDARD AND APPROVED BY THE ENGINEER.

SCALE: NOT TO SCALE



MARBLE FALLS
800 THIRD STREET
MARBLE FALLS, TX 78654
PH: (830) 693-6737

These documents were prepared by,
or under the supervision of:

ERIC BELAJ 107148 May 31, 2017
Engineer's Name PE# Date

[Signature]
Engineer's Signature

SECTION

PAVING

DETAIL NO.

PV-32

TITLE

SECURITY FENCE

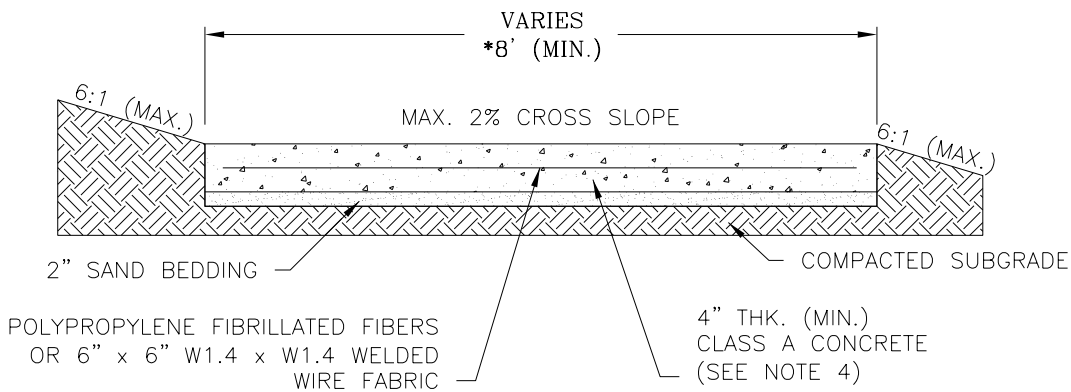
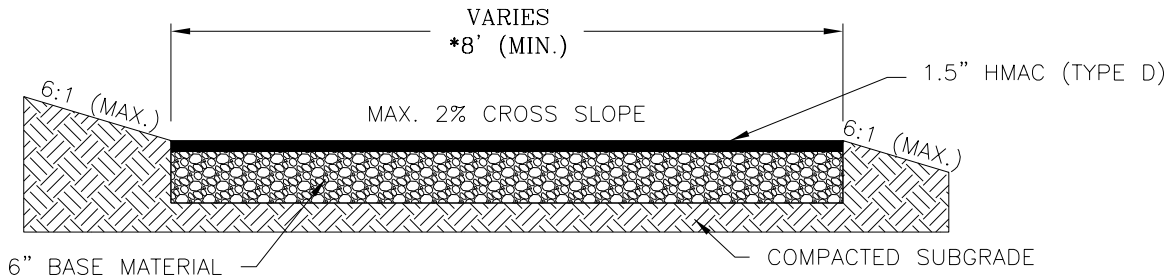
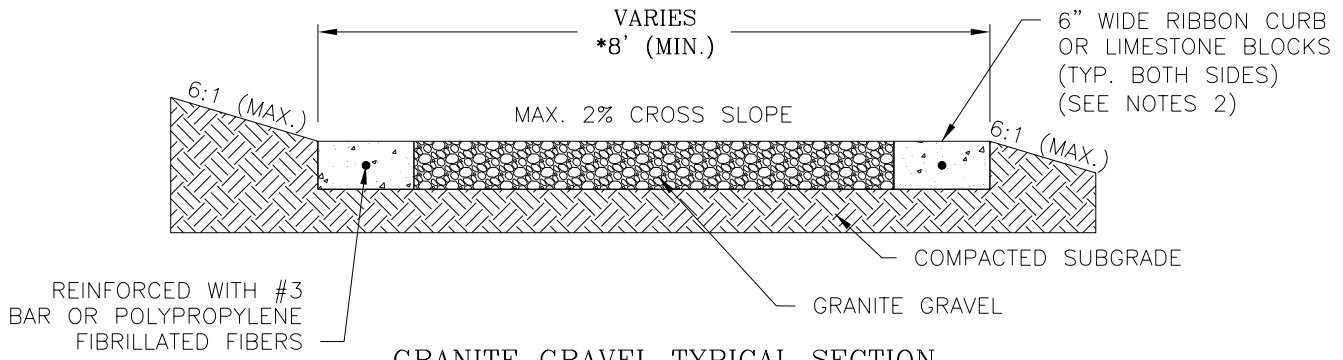

NOTES:

- HIKE AND BIKE SURFACE MATERIAL SHALL BE EITHER GRANITE GRAVEL, HMAC, OR CONCRETE. DEPTH SHALL BE AS INDICATED IN THE CONSTRUCTION DOCUMENTS, BUT SHALL NOT BE LESS THAN SHOWN.
- DEPTH OF RIBBON CURB OR BLOCKS SHALL MATCH THE DEPTH OF THE HIKE AND BIKE TRAIL SURFACE.
- ALL HIKE AND BIKE TRAILS SHALL BE CONSTRUCTED IN ACCORDANCE WITH THE REQUIREMENTS AMERICANS WITH DISABILITIES ACT (ADA).
- CONCRETE EXPANSION JOINTS SHALL BE PROVIDED IN ACCORDANCE WITH SD-10.

* A MINIMUM WIDTH OF 10' SHALL BE REQUIRED FOR EMERGENCY ACCESS THROUGH THE ENTIRE LENGTH OF HIKE AND BIKE TRAILS THAT SHALL EXTEND MORE THAN 200' FROM PUBLIC RIGHT OF WAY. ALL WIDTHS SHALL BE AS REQUIRED BY THE CITY OF MARBLE FALLS.

SCALE: NOT TO SCALE



MARBLE FALLS
800 THIRD STREET
MARBLE FALLS, TX 78654
PH: (830) 693-6737

These documents were prepared by,
or under the supervision of:

ERIC BELAJ 107148 May 31, 2017
Engineer's Name PE# Date

Engineer's Signature

SECTION

PAVING

DETAIL NO.

PV-33

TITLE

HIKE & BIKE
TRAIL SECTION (1 OF 2)

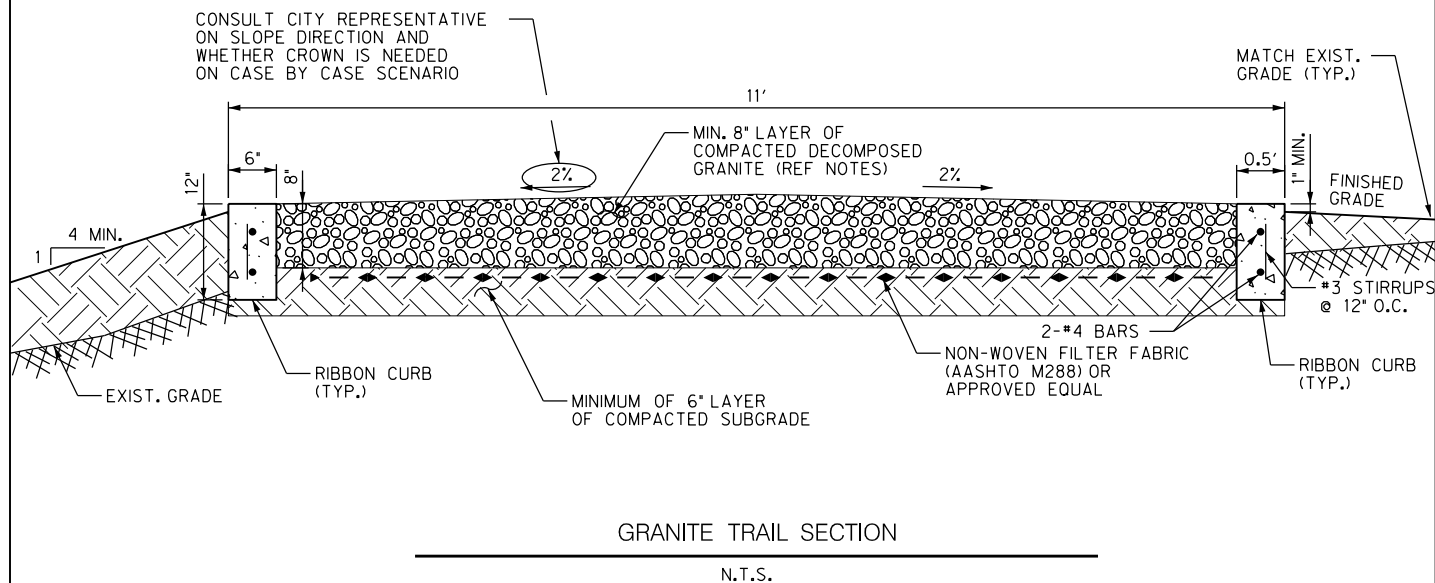

NOTES:

1. SUBGRADE SHALL BE COMPACTED TO AN OPTIMUM MOISTURE CONTENT, TO 95% AT (+/-)2% MODIFIED PROCTOR DENSITY AS DETERMINED BY ASTM D1557.
2. A MINIMUM OF 4" TOPSOIL SHALL BE REMOVED THROUGHOUT THE IMPACTED AREA PRIOR TO INSTALLATION OF PROPOSED IMPROVEMENTS.
3. CONTRACTOR SHALL ESTABLISH GRASS ON ALL IMPACTED AREAS.
4. THE NON-WOVEN FABRIC SHALL BE OF MEDIUM WEIGHT. CONTRACTOR SHALL PROVIDE A FABRIC SAMPLE TO CITY REPRESENTATIVE FOR APPROVAL.
5. CONTRACTOR SHALL PROVIDE A SAMPLE OF THE CRUSHED GRANITE TO CITY REPRESENTATIVE FOR APPROVAL.
6. RIBBON CURBS SHALL HAVE A CONTRACTION JOINT AT 10' O.C. AND AN EXPANSION JOINT AT 40' O.C. PER ASTM C1752.
7. ALL CONCRETE SHALL BE CLASS "A" CONC.
8. ALL CONSTRUCTION SHALL BE DONE PER CITY OF MARBLE FALLS STANDARDS AND SPECIFICATIONS.

SCALE: NOT TO SCALE



MARBLE FALLS
800 THIRD STREET
MARBLE FALLS, TX 78654
PH: (830) 693-6737

These documents were prepared by,
or under the supervision of:

ERIC BELAJ 107148 May 31, 2017
Engineer's Name PE# Date

Engineer's Signature

SECTION

PAVING

DETAIL NO.

PV-34

TITLE

HIKE & BIKE
TRAIL SECTION (2 OF 2)

NOTES:

1. AVOID DIRECT DRAINING DOWNSPOUT ONTO SIDEWALK.
2. UPON EXCAVATION REVIEW OPTIONS WITH CITY PRIOR TO INSTALLATION OF NEW SIDEWALK OR VERTICAL CONSTRUCTION.

TREE TYPE MUST BE APPROVED BY CITY. TREE TYPE MUST BE FROM CITY APPROVED TREE & PLANT LIST IN THE LANDSCAPE ORDINANCE.

BRICK AND LIMESTONE VENEER (TYP.)

IRRIGATION AND ELECTRIC OUTLET TO BE PROVIDED TO EACH, TYPICAL.

PLANTING BASIN DIMENSIONS SHALL BE BASED ON TREE TYPE AND SIZE WITH A MINIMUM WIDTH OF 4'.

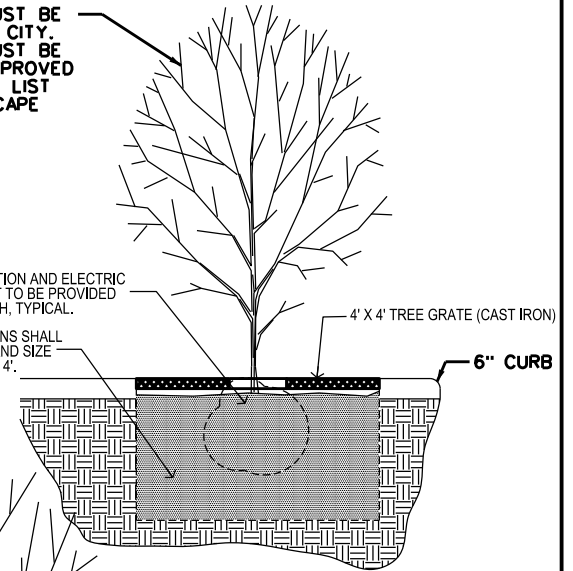

TREE PLANTING SECTION

SHADE TREE AT 25' O.C. W/ IRRIGATION AND ELEC. OUTLET

PROPERTY LINE

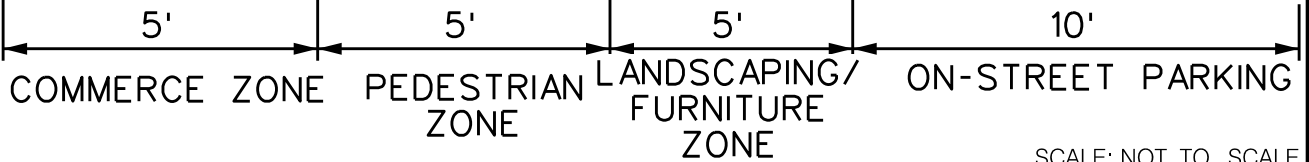
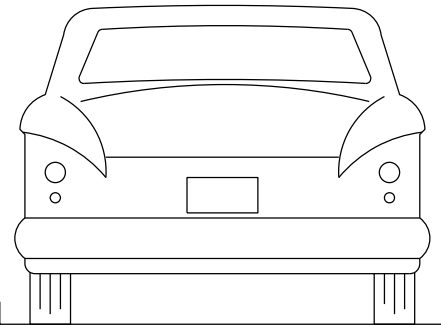

SCALE: NOT TO SCALE



MARBLE FALLS
800 THIRD STREET
MARBLE FALLS, TX 78654
PH: (830) 693-6737

These documents were prepared by, or under the supervision of:

KACEY PAUL 120200 September 19, 2018
Engineer's Name PE# Date

Engineer's Signature

SECTION

PAVING

DETAIL NO.

PV-35

TITLE

DOWNTOWN SIDEWALK SECTION

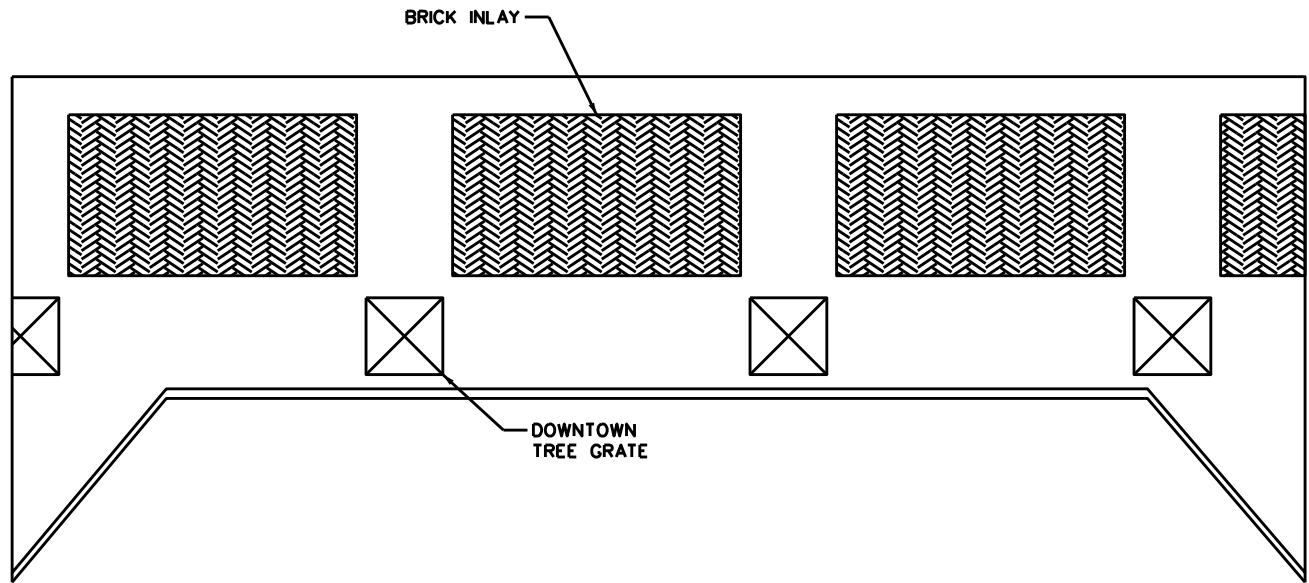

NOTES:

1. BRICK INLAYS SHALL BE RED BRICK IN A HERRINGBONE PATTERN. THERE SHALL BE A MINIMUM RATIO OF BRICK INLAY TO CONCRETE OF 3:1 AND THE SPACE BETWEEN THE CONCRETE SHALL BE A MINIMUM OF 4'. FINAL LAYOUT DESIGN MUST BE APPROVED BY CITY OF MARBLE FALLS.
2. SIDEWALKS SHALL COMPLY WITH TCSS FOR TYPICAL SIDEWALK SECTION, ASTM STANDARDS, AND ADA REQUIREMENTS.



SCALE: NOT TO SCALE



MARBLE FALLS
 800 THIRD STREET
 MARBLE FALLS, TX 78654
 PH: (830) 693-6737

These documents were prepared by,
 or under the supervision of:

KACEY PAUL 120200 September 19, 2018
 Engineer's Name PE# Date

Engineer's Signature

SECTION

PAVING

DETAIL NO.

PV-36

TITLE

DOWNTOWN SIDEWALK
 SECTION

HANDRAIL FABRICATION NOTES:

1. BALUSTERS SHALL BE EVENLY SPACE 4" O.C. MAX WITH NO OPENINGS TO EXCEED $\frac{3}{4}$ ".

2. HANDRAIL SHALL BE SECURED TO SIDEWALK WITH STEEL MOUNTING BASE PLATE WITH $\frac{1}{2}$ " X 10" ANCHOR BOLTS (STAINLESS STEEL). BASE PLATES SHALL BE SPACED NO MORE THAN 6' APART.

3. HANDRAIL SHALL HAVE THE FOLLOWING MATERIAL PARAMETERS:

- a) TOP OF RAIL - $1\frac{1}{4}$ " X $\frac{1}{4}$ " X $\frac{1}{8}$ " STEEL TUBE.
- b) BALUSTER - $\frac{1}{2}$ " STEEL BAR
- c) BOTTOM RAIL - $1\frac{1}{4}$ " X $1\frac{1}{4}$ " X $1\frac{1}{8}$ " STEEL TUBE.

4. TOP OF HANDRAIL SHALL HAVE A MILLED STEEL CAP WITH EASE EDGES.

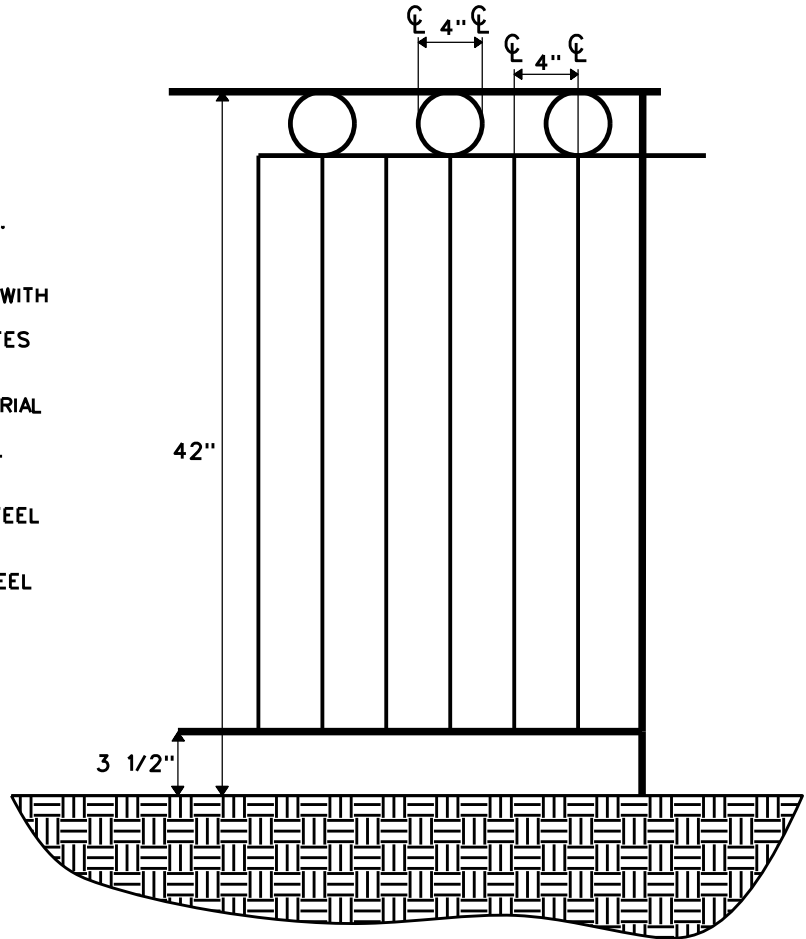

GENERAL NOTES:

- 1. HANDRAIL SHALL BE PARALLEL TO THE GROUND.
- 2. HANDRAILS SHALL HAVE A POWDERCOAT BLACK FINISH.
- 3. HANDRAIL SHALL MATCH HANDRAILS IN THE DOWNTOWN AREA AND PROPERLY CONNECT WITH NEIGHBORING HANDRAIL, WHERE POSSIBLE.

SCALE: NOT TO SCALE



MARBLE FALLS
 800 THIRD STREET
 MARBLE FALLS, TX 78654
 PH: (830) 693-6737

These documents were prepared by,
 or under the supervision of:

KACEY PAUL 120200 September 19, 2018
 Engineer's Name PE# Date

Engineer's Signature

SECTION

PAVING

DETAIL NO.

PV-37

TITLE

DOWNTOWN
 PUBLIC
 HANDRAILS

TREE TYPE MUST BE APPROVED BY CITY. TREE TYPE MUST BE FROM CITY APPROVED TREE & PLANT LIST IN THE LANDSCAPE ORDINANCE.

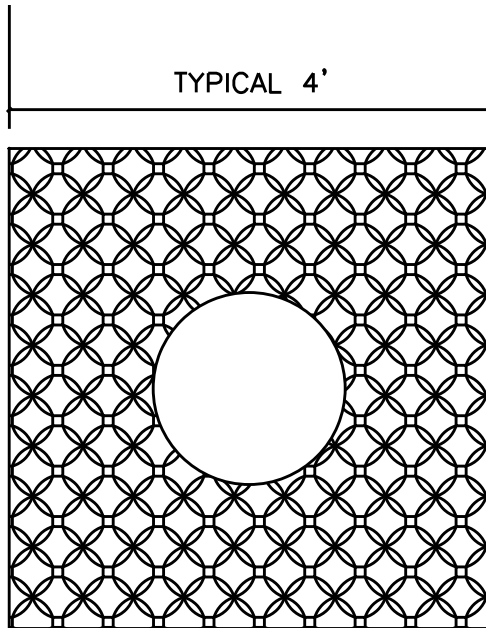

TREE GRATE

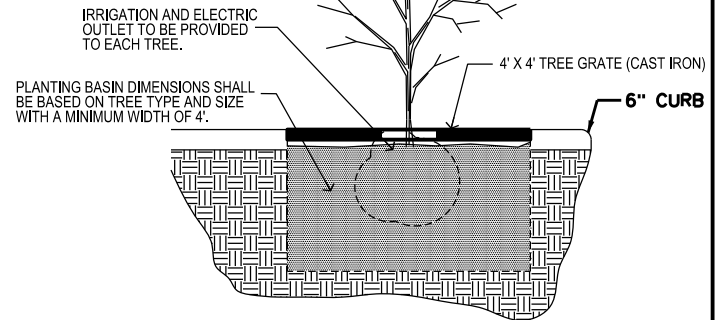

TREE PLANTING SECTION

NOTES:

1. TYPICAL GRATES SHALL BE 4' X 4' AND SHALL CONSIST OF NO FEWER THAN 2 PIECES. GRATE PIECES SHALL BE BOLTED TOGETHER.
2. GRATES SHALL BE CAST IRON.
3. TREE GRATES SHALL BE DESIGNED TO COMPLY WITH ADA STANDARDS.
4. PATTERN VARIATION ON TREE GRATE SHALL SLOT SIZE OPENINGS NO LARGER THAN 3/8". PATTERN DESIGNS SHALL BE APPROVED BY CITY OF MARBLE FALLS.
5. ALL GRATES SHALL HAVE A POWDERCOAT BLACK FINISH.
6. CENTER OPENING SHALL BE SIZED APPROPRIATELY FOR TREE SIZE TO LAY FLAT, PROTECT YOUNGER TREES, AND ALLOW FOR TREE GROWTH.
7. TREE GRATES SHALL BE 1 1/2" THICK WITH A STEEL SUPPORT FRAME SET INTO CONCRETE PAVING.

SCALE: NOT TO SCALE



MARBLE FALLS
 800 THIRD STREET
 MARBLE FALLS, TX 78654
 PH: (830) 693-6737

These documents were prepared by,
 or under the supervision of:

KACEY PAUL 120200 September 19, 2018
 Engineer's Name PE# Date

Engineer's Signature

SECTION

PAVING

DETAIL NO.

PV-39

TITLE

DOWNTOWN TREE GRATES

NOTES:

1. A MINIMUM OF 4" TOPSOIL SHALL BE REMOVED THROUGHOUT THE IMPACTED AREA PRIOR TO INSTALLATION OF PROPOSED IMPROVEMENTS.
3. CONTRACTOR SHALL ESTABLISH GRASS ON ALL IMPACTED AREAS.
3. ALL CONCRETE SHALL BE CLASS "A" CONC.
4. ALL CONSTRUCTION SHALL BE DONE PER CITY OF MARBLE FALLS STANDARDS AND SPECIFICATIONS.
5. PLACE 12"x12"x12" AREA OF CRUSHED ROCK OR GRAVEL WRAPPED IN GEOFABRIC AT EVERY WEEP WHOLE.

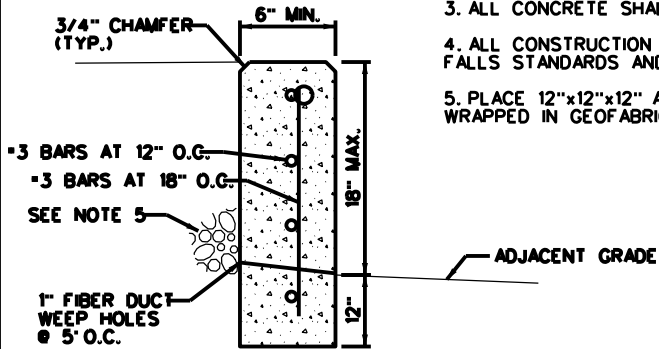

TY-1 WALL SECTION

N.T.S.

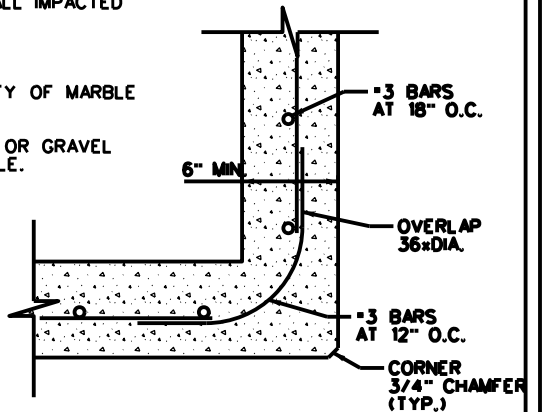

TY-1 WALL CORNER SECTION

N.T.S.

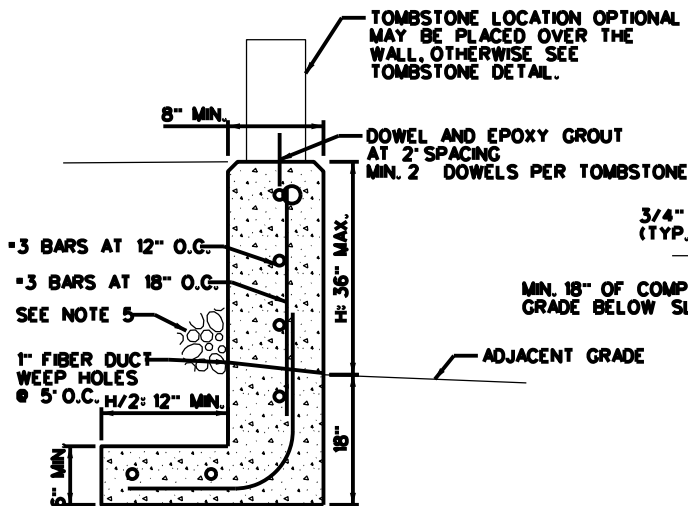

TY-2 WALL SECTION

N.T.S.

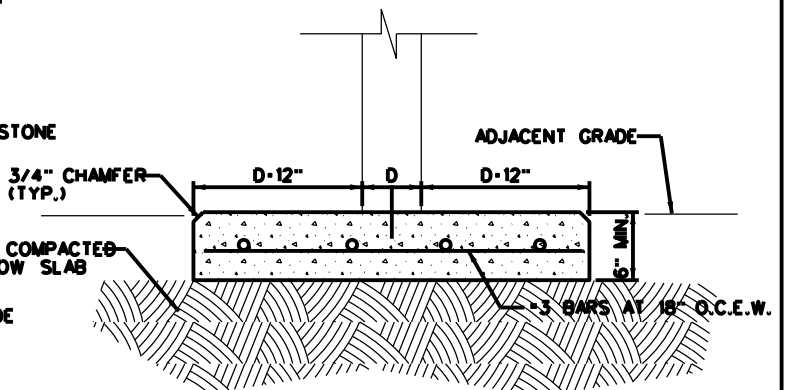

- NOTE:**
1. ON THE LONGITUDINAL EDGE THE SLAB SHALL BE 6" MINIMUM BEYOND THE TOMBSTONE.
 2. DOWEL AND EPOXY GROUT AT 2' SPACING MIN. 2 DOWELS PER TOMBSTONE. DOWEL SHALL BE 8" MIN.

TOMBSTONE SECTION

N.T.S.

SCALE: NOT TO SCALE



MARBLE FALLS
800 THIRD STREET
MARBLE FALLS, TX 78654
PH: (830) 693-6737

These documents were prepared by,
or under the supervision of:

ERIC BELAJ 107148 MAY 31, 2017
Engineer's Name PE# Date

[Signature]
Engineer's Signature

SECTION

PAVING

DETAIL NO.

PV-40

TITLE

CEMETERY WALL SECTION

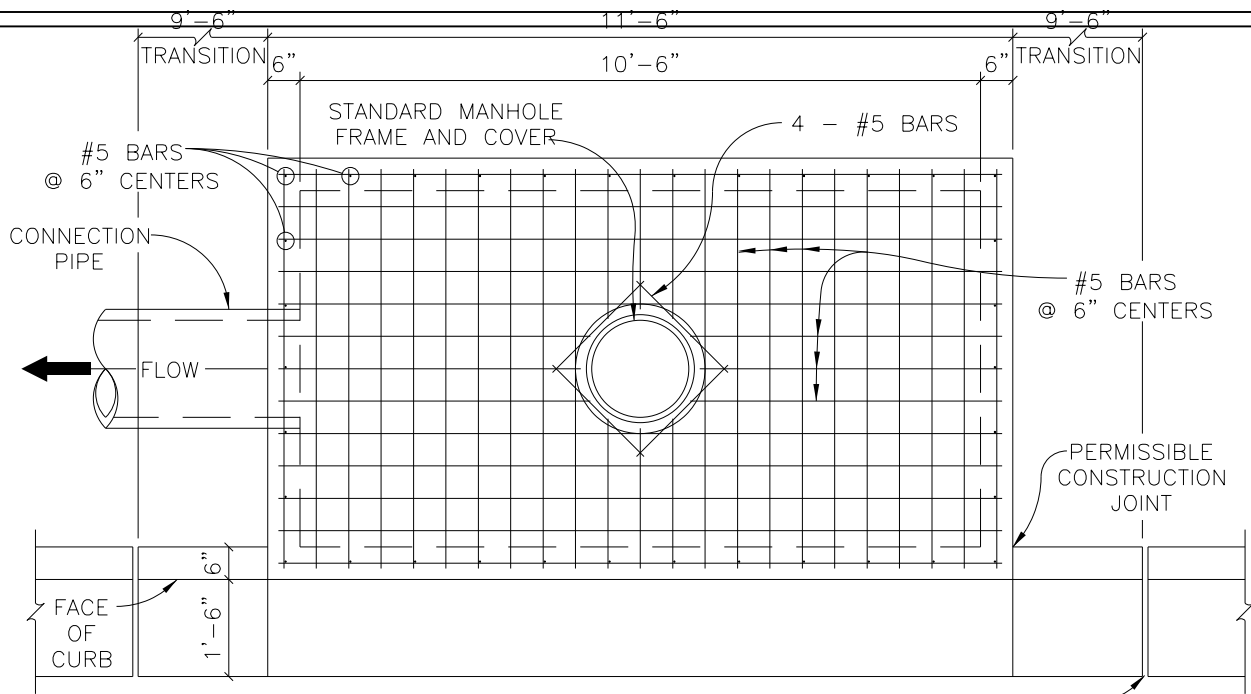

PLAN

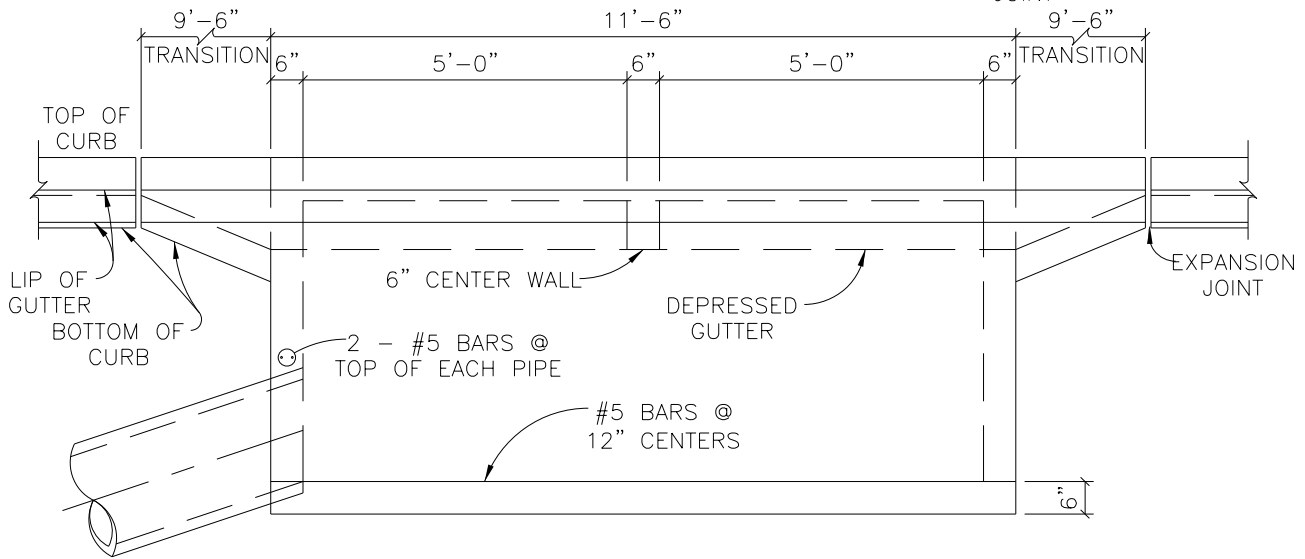

FRONT ELEVATION

NOTES:

1. ALL CONCRETE SHALL BE MINIMUM 5 SACK CONCRETE WITH A 28 DAY COMPRESSIVE STRENGTH OF CLASS A MINIMUM.
2. STORM SEWER PIPE MATERIAL TO BE AS INDICATED IN THE CONTRACT DOCUMENTS.
3. AT INLETS WHERE MULTIPLE PIPES ARE CONNECTED, THE INVERT SHALL BE GROUTED AND SHAPED AS REQUIRED TO PROVIDE AN EFFICIENT FLOW PATH FOR EACH PIPE.
4. WHERE AN INLET HAS MULTIPLE PIPES, ALIGN FLOW DIRECTIONS AS CLOSELY AS POSSIBLE TO MINIMIZE DIRECTIONAL CHANGES.

SCALE: NOT TO SCALE



MARBLE FALLS
 800 THIRD STREET
 MARBLE FALLS, TX 78654
 PH: (830) 693-6737

These documents were prepared by,
 or under the supervision of:

ERIC BELAJ 107148 May 31, 2017
 Engineer's Name PE# Date

[Signature]
 Engineer's Signature

SECTION
STORM DRAINAGE

DETAIL NO.
 SD-1

TITLE
 STANDARD CURB INLET

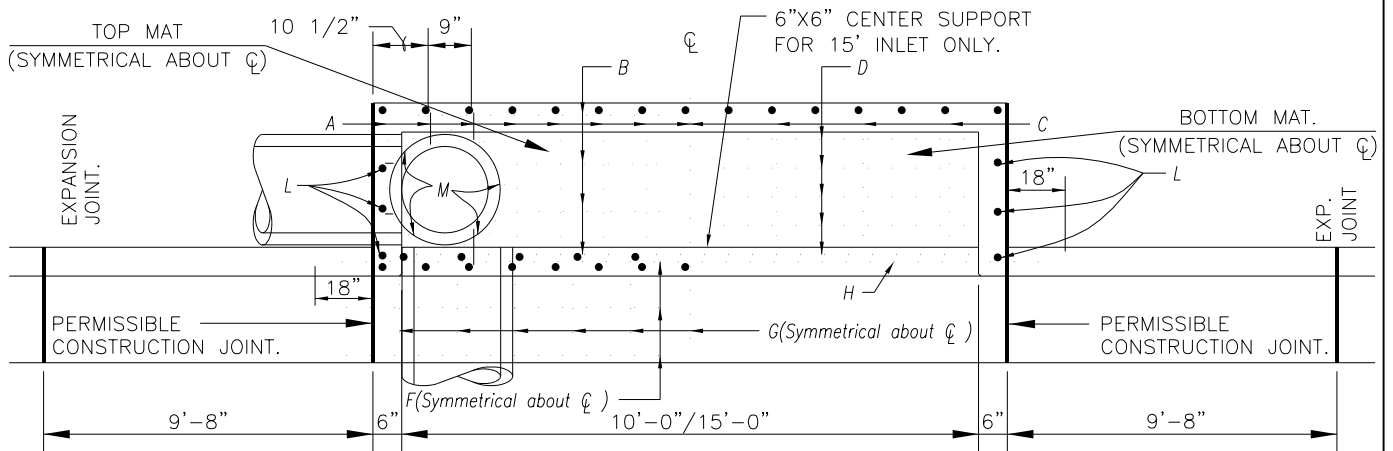

GENERAL LAYOUT

REINFORCING STEEL SCHEDULE					
BARS	SIZE	SPACING	BARS	SIZE	SPACING
A	5	9"	G	4	9"
B	4	10"	H	6	-
C	4	18"	J	4	12"
D	6	6"	K	4	9"
E	4	12"	L	4	12"
F	4	10"	M	5	-

NOTES:

- ALL CONCRETE SHALL BE CLASS "A".
- ALL REINFORCING STEEL SHALL BE GRADE 60.
- DIMENSIONS RELATING TO REINFORCING STEEL ARE TO CENTERS OF BARS.
- VERTICAL STEEL MAY BE SPLICED (15' MIN. LAP) IN THE LOWER ONE-HALF OF ALL INLET WALLS.
- IN AREAS OF CONFLICT BETWEEN REINFORCING STEEL, PIPES AND MANHOLE FRAME THE REINFORCEMENT SHALL BE BENT OR ADJUSTED TO CLEAR AS DIRECTED BY THE ENGINEER.
- PAYMENT WILL BE MADE FOR EACH INLET OF THE TYPE SPECIFIED, COMPLETE IN PLACE INCLUDING MANHOLE FRAME AND COVER.
- CHAMFER ALL EXPOSED EDGES 3/4".
- MANHOLE FRAME AND COVERS SHALL BE FURNISHED WITH THE CAST-ON EYES AND CHAIN AS SHOWN IN THE CAST-ON EYE AND COVER CHAIN DETAILS.
- THE CONTRACTOR MAY PROPOSE ALTERNATE PROCEDURES FOR THE CONSTRUCTION OF INLETS, INCLUDING PRECAST UNITS. PLANS FOR SUCH PROPOSED ALTERNATES SHALL BE SUBMITTED TO THE ENGINEER FOR REVIEW AND APPROVAL BEFORE CONSTRUCTION.
- ALL INLET WALLS SHALL BE FORMED EXCEPT WHERE THE NATURE OF THE SURROUNDING MATERIAL IS SUCH THAT IT CAN BE TRIMMED TO A SMOOTH VERTICAL FACE. WHEN INLET WALLS ARE PLACED TO NEAT EXCAVATION LINES, THE WALL THICKNESS SHALL NOT EXCEED 10 INCHES.
- PAYMENT FOR INLETS AT THE CONTRACT PRICE SHALL INCLUDE THE TRANSITION CURB.
- INVERT OF INLET SHALL BE SLOPED 1:20 WITH FILL CONCRETE.
- AT INLETS WHERE MULTIPLE PIPES ARE CONNECTED, THE INVERT SHALL BE GROUTED AND SHAPED AS REQUIRED TO PROVIDE AN EFFICIENT FLOW PATH FOR EACH PIPE.
- WHERE AN INLET HAS MULTIPLE PIPES, ALIGN FLOW DIRECTIONS AS CLOSELY AS POSSIBLE TO MINIMIZE DIRECTIONAL CHANGES.
- INSTALL A 6" CENTER WALL SUPPORT IN THE MOUTH OF THE INLET EVERY 10'.

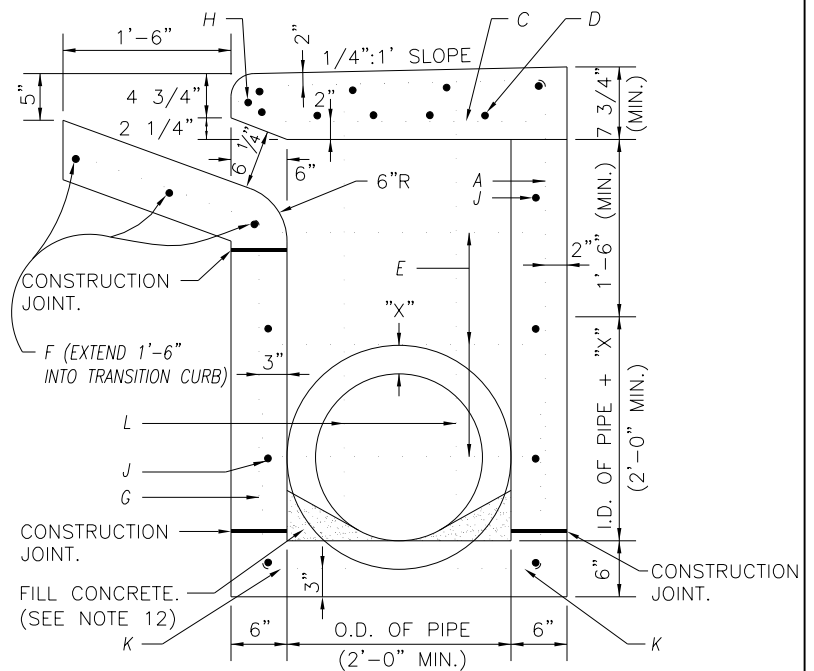

ELEVATION - SECTION LAYOUT

SCALE: NOT TO SCALE



MARBLE FALLS
 800 THIRD STREET
 MARBLE FALLS, TX 78654
 PH: (830) 693-6737

These documents were prepared by,
 or under the supervision of:

ERIC BELAJ 107148 May 31, 2017
 Engineer's Name PE# Date

[Signature]
 Engineer's Signature

SECTION
STORM DRAINAGE

DETAIL NO.
 SD-2

TITLE
 EXTENDED CURB INLET

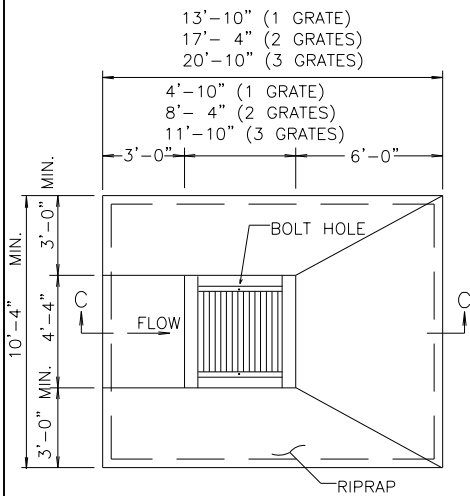

DITCH BLOCK PLAN

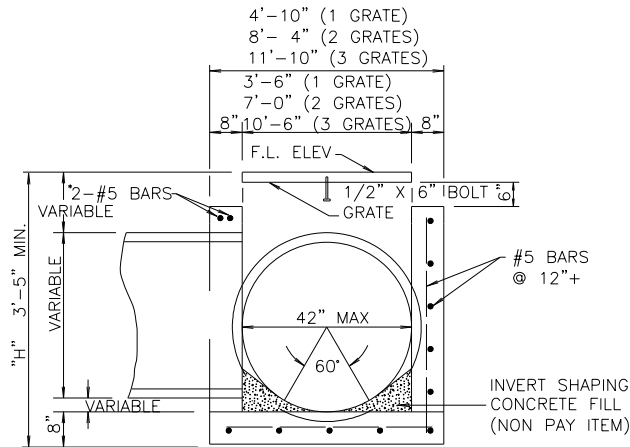

SECTION A-A

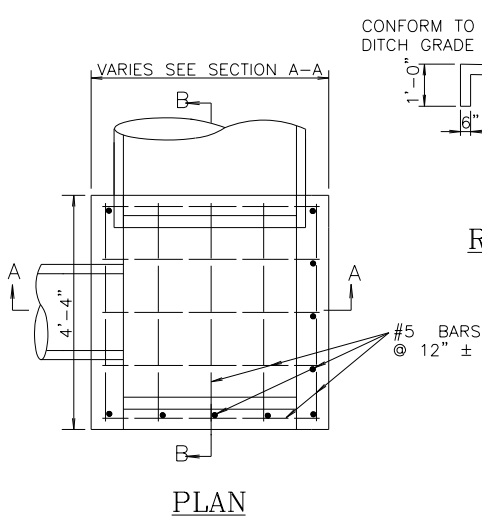

PLAN

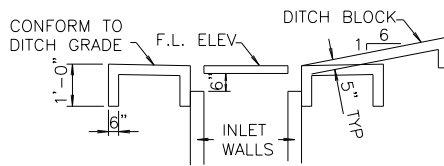

SECTION C-C
RIPRAP DETAILS

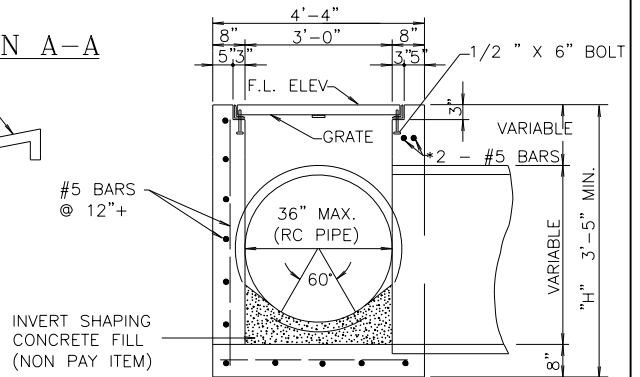

SECTION B-B

* WHEN HEIGHT ABOVE PIPE IS 2'-6" OR LESS, PLACE 2 - #5 BARS AS SHOWN.

*INLET SHOWN IS FOR A STANDARD 3'X3' INLET. INLET DIMENSIONS SHALL BE ADJUSTED FOR OTHER SIZES.

GENERAL NOTES:

1. CONCRETE FOR DROP INLETS SHALL BE CLASS "A".
2. BOLTS, NUTS, AND WASHERS SHALL BE GALVANIZED.
3. REFER TO THE TXDOT STANDARD SPECIFICATION FOR CONSTRUCTION AND MAINTANANCE OF HIGHWAYS, STREETS AND BRIDGES, JUNE 2004. PLACEMENT OF CONCRETE RIPRAP CLASS "B" AND GRATES SHALL BE IN ACCORDANCE WITH TXDOT SPECIFICATION 471, "FRAMES, GRATES, RINGS AND COVERS." PAYMENT FOR THESE ITEMS WILL NOT BE MADE DIRECTLY, BUT SHALL BE CONSIDERED SUBSIDIARY TO ITEM 701.10, "GRATE INLET."
4. FOR INSTALLATION ON BOX CULVERTS, ADJUSTMENTS MAY BE MADE BY THE ENGINEER TO FIT UNUSUAL CONDITIONS.
5. RIPRAP CONCRETE CLASS "B" SHALL BE PLACED AS SOON AS PRACTICAL TO MINIMIZE EROSION.
6. REINFORCEMENT FOR RIPRAP SHALL BE WWF 6X6-W2.9XW2.9.
7. CONNECTING PIPES SHOULD ENTER WITHIN 10 DEGREES OF NORMAL TO INLET WALL. IF NECESSARY, PIPE ELBOW OR CURVED APPROACH ALIGNMENT SHOULD BE USED TO STAY WITHIN THIS LIMIT.
8. EXCAVATION AND BACKFILL WILL NOT BE PAID FOR DIRECTLY, BUT SHALL BE CONSIDERED SUBSIDIARY TO ITEM 701.10, "GRATE INLET."

GRATE DETAILS

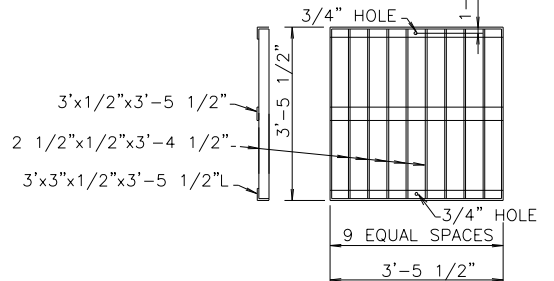

NOTE:
FILLET WELD ALL JOINING SURFACES.

SCALE: NOT TO SCALE



MARBLE FALLS
800 THIRD STREET
MARBLE FALLS, TX 78654
PH: (830) 693-6737

These documents were prepared by,
or under the supervision of:

ERIC BELAJ 107148 May 31, 2017
Engineer's Name PE# Date

[Signature]
Engineer's Signature

SECTION
STORM DRAINAGE

DETAIL NO.
SD-3

TITLE
AREA INLET

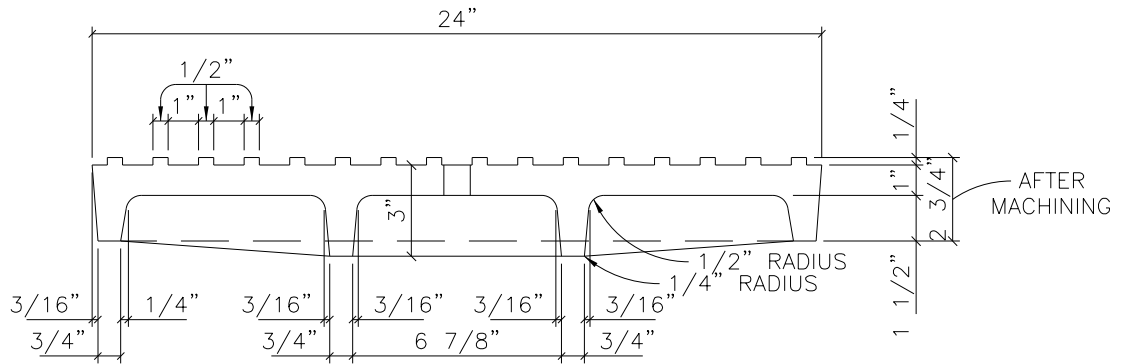

SECTION

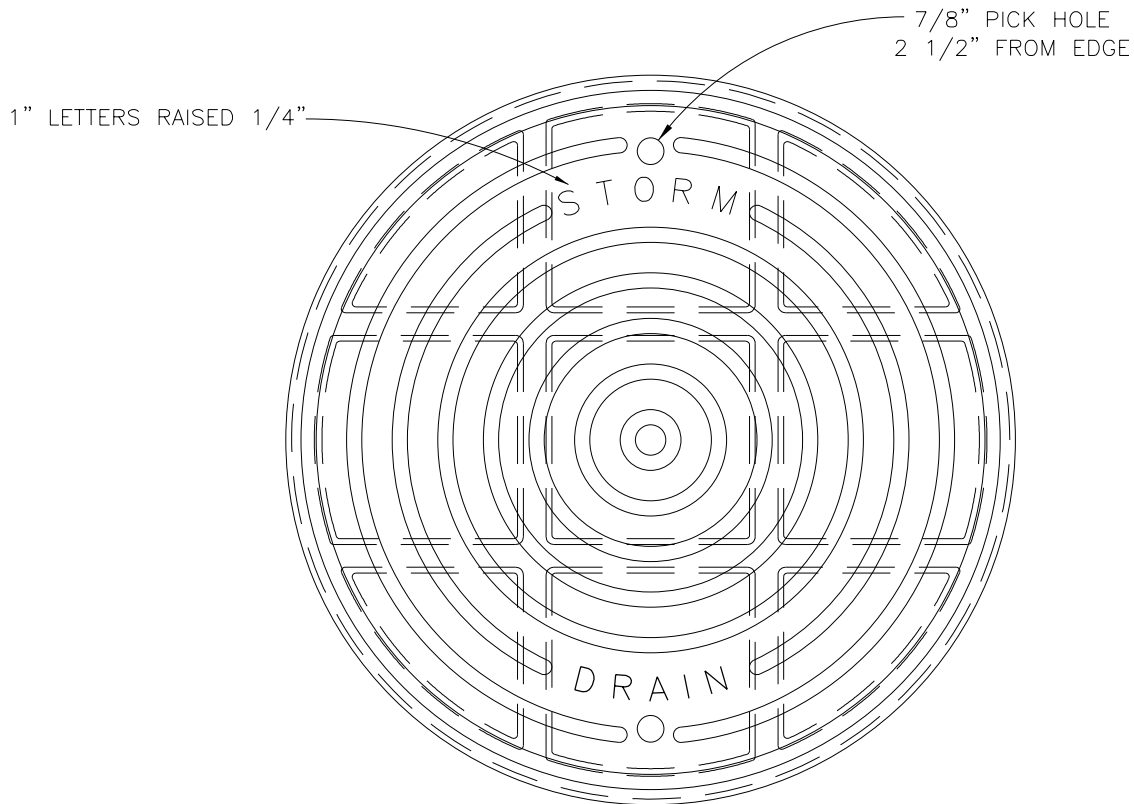

PLAN

NOTE:

1. REQUIRED FOR USE IN STORM SEWER STRUCTURES HAVING A DEPTH OF 4- FEET OR LESS.
2. ALL MANHOLE COVERS SHOULD SAY "STORM DRAIN"

SCALE: NOT TO SCALE



MARBLE FALLS
800 THIRD STREET
MARBLE FALLS, TX 78654
PH: (830) 693-6737

These documents were prepared by,
or under the supervision of:

ERIC BELAJ 107148 May 31, 2017
Engineer's Name PE# Date

Engineer's Signature

SECTION
STORM DRAINAGE

DETAIL NO.
SD-4

TITLE
24" MANHOLE COVER
(1 OF 2)

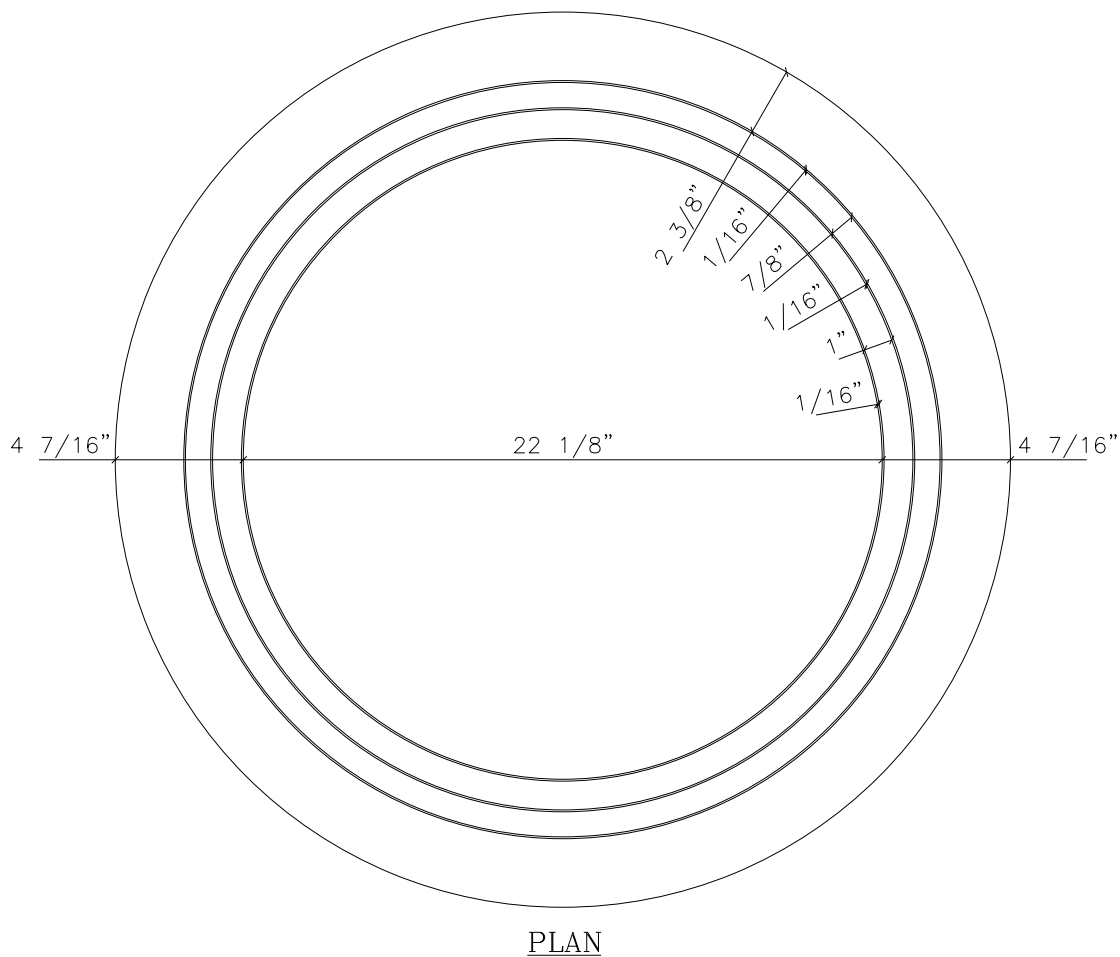
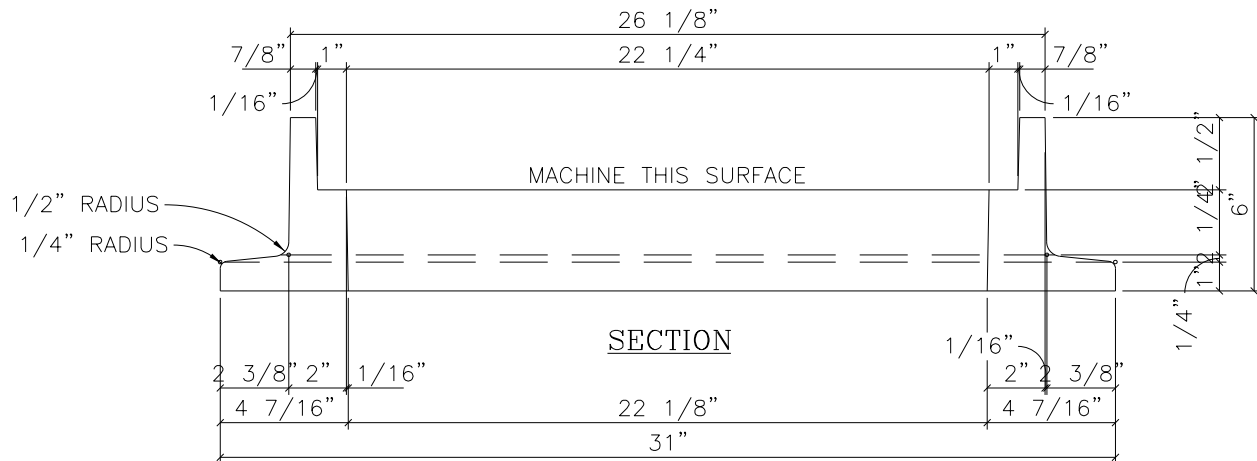

SCALE: NOT TO SCALE



MARBLE FALLS
800 THIRD STREET
MARBLE FALLS, TX 78654
PH: (830) 693-6737

These documents were prepared by,
or under the supervision of:

ERIC BELAJ 107148 May 31, 2017
Engineer's Name PE# Date

Engineer's Signature

SECTION
STORM DRAINAGE

DETAIL NO.
SD-5

TITLE
24" MANHOLE COVER
(2 OF 2)



PLAN

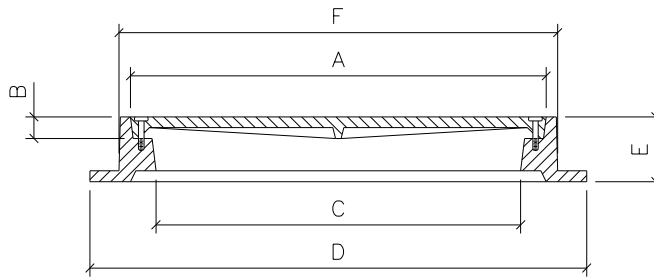

SECTION

NOTES:

1. REQUIRED FOR USE IN STORM SEWER STRUCTURES HAVING A DEPTH OF GREATER THAN 4- FEET.
2. STORM SEWER MANHOLE FRAME AND COVER TO BE EAST JORDAN IRON WORKS, INC. V-1600-5, OR APPROVED EQUAL.
3. COVER TO BE TYPE 36 MARKED "STORM SEWER".
4. LID SHALL HAVE A TYPE 4 STAINLESS STEEL PICK BAR. REFER TO PICK BAR DETAIL.

	DIMENSIONS						COVER		RING		SET
	A	B	C	D	E	F	CASTING #	WEIGHT	CASTING #	WEIGHT	WEIGHT
V-1600-5	38	2	36	46	6	40	41600545	365 LBS	41600510	320 LBS	685 LBS

SCALE: NOT TO SCALE



MARBLE FALLS
 800 THIRD STREET
 MARBLE FALLS, TX 78654
 PH: (830) 693-6737

These documents were prepared by,
 or under the supervision of:

ERIC BELAJ 107148 May 31, 2017
 Engineer's Name PE# Date

Engineer's Signature

SECTION

STORM DRAINAGE

DETAIL NO.

SD-6

TITLE

38" MANHOLE COVER

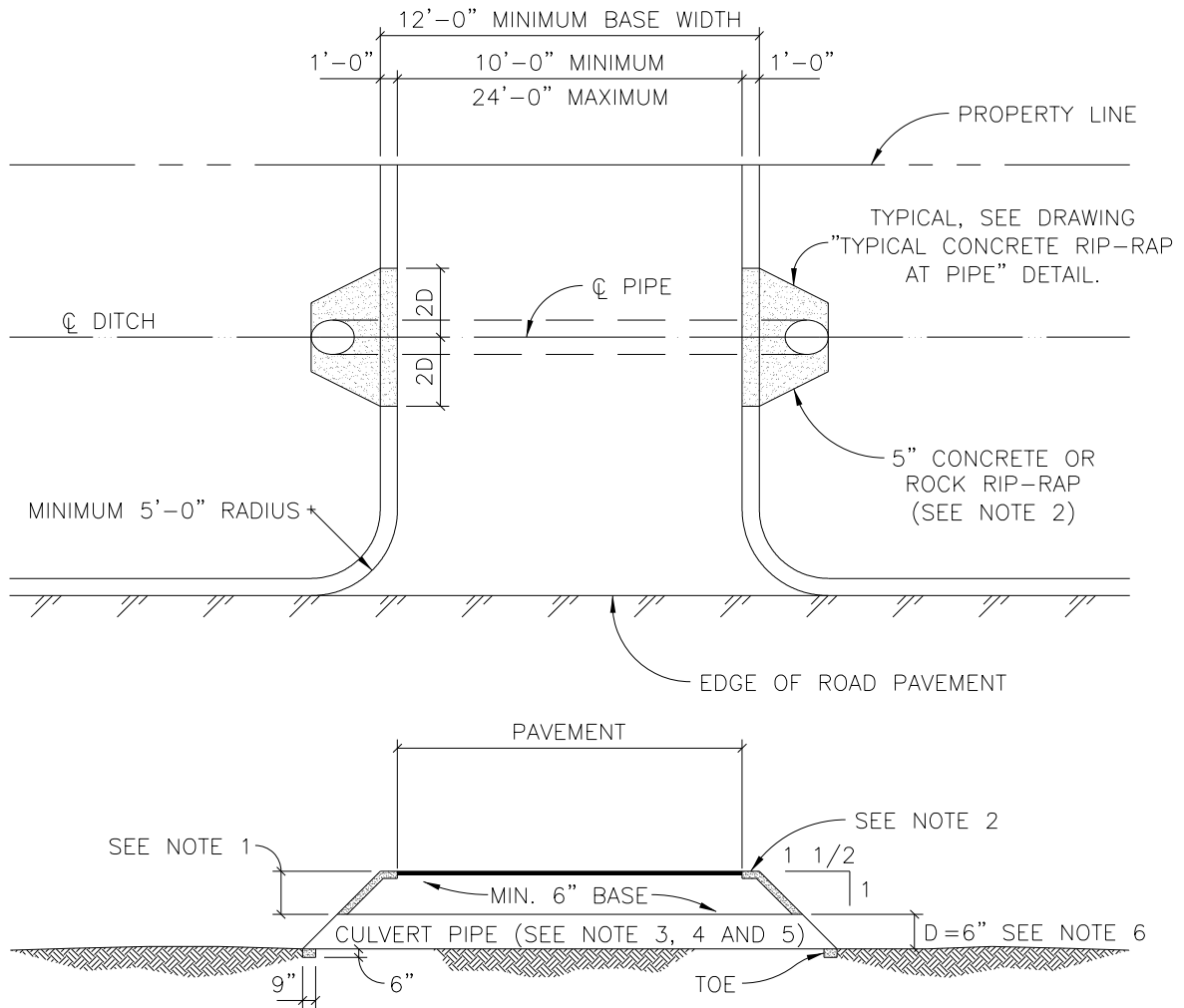

NOTES:

1. MINIMUM COVER OVER CULVERT PIPE SHALL BE 6" (SEE NOTE 5).
2. 5" CONCRETE OR ROCK RIP-RAP SHALL BE INSTALLED.
3. CULVERT PIPE TO BE MINIMUM OF 18" DIAMETER.
4. CULVERT PIPE MATERIAL TO BE R.C.P. (CLASS III), A.D.S. "N-12" , AS DIRECTED BY THE ENGINEER.
5. MINIMUM COVER OVER CULVERT PIPE SHALL PROVIDE H2O LOADING.
6. BACKFILL AROUND CULVERT PIPE SHALL BE SELECT MATERIAL TO BE PLACED AND COMPACTED TO 95%.
7. WHEN CULVERT INSTALLATION CONSISTS OF A SINGLE CIRCULAR CONDUIT OF 48" DIAMETER OR LESS INSTALLED IN AN EARTHEN DITCH OR CHANNEL, THE DRAINAGE CONDUIT SHALL BE AT ELEVATION 6" BELOW THE NOMINAL FLOW LINE OF THE DITCH OR CHANNEL.

SCALE: NOT TO SCALE



MARBLE FALLS
 800 THIRD STREET
 MARBLE FALLS, TX 78654
 PH: (830) 693-6737

These documents were prepared by,
 or under the supervision of:

ERIC BELAJ 107148 May 31, 2017
 Engineer's Name PE# Date

Engineer's Signature

SECTION
STORM DRAINAGE

DETAIL NO.
 SD-7

TITLE
 RESIDENTIAL DRIVEWAY
 CULVERT

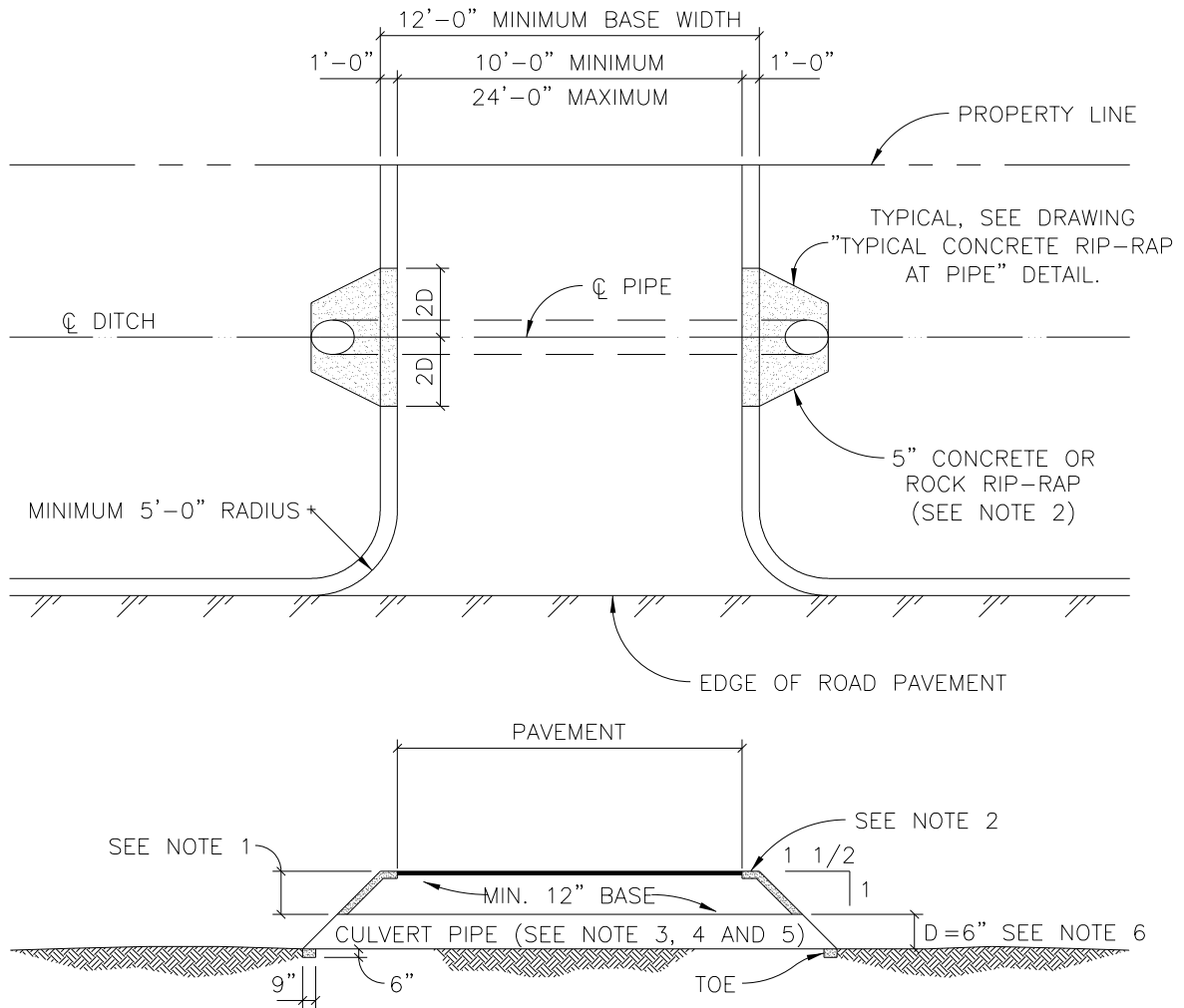

NOTES:

1. MINIMUM COVER OVER CULVERT PIPE SHALL BE 6" (SEE NOTE 5).
2. 5" CONCRETE RIP-RAP SHALL BE INSTALLED WITH #3 BARS AT 18" O.C.E.W OR W6xW6 WIRE MESH.
3. CULVERT PIPE TO BE MINIMUM OF 18" DIAMETER.
4. CULVERT PIPE MATERIAL TO BE R.C.P. (CLASS III), A.D.S. "N-12", AS DIRECTED BY THE ENGINEER.
5. MINIMUM COVER OVER CULVERT PIPE SHALL PROVIDE H2O LOADING.
6. BACKFILL AROUND CULVERT PIPE SHALL BE SELECT MATERIAL TO BE PLACED AND COMPACTED TO 95%.
7. WHEN CULVERT INSTALLATION CONSISTS OF A SINGLE CIRCULAR CONDUIT OF 48" DIAMETER OR LESS INSTALLED IN AN EARTHEN DITCH OR CHANNEL, THE DRAINAGE CONDUIT SHALL BE AT ELEVATION 6" BELOW THE NOMINAL FLOW LINE OF THE DITCH OR CHANNEL.

SCALE: NOT TO SCALE



MARBLE FALLS
 800 THIRD STREET
 MARBLE FALLS, TX 78654
 PH: (830) 693-6737

These documents were prepared by,
 or under the supervision of:

ERIC BELAJ 107148 May 31, 2017
 Engineer's Name PE# Date

Engineer's Signature

SECTION
STORM DRAINAGE

DETAIL NO.
 SD-8

TITLE
 NON-RESIDENTIAL
 DRIVEWAY CULVERT

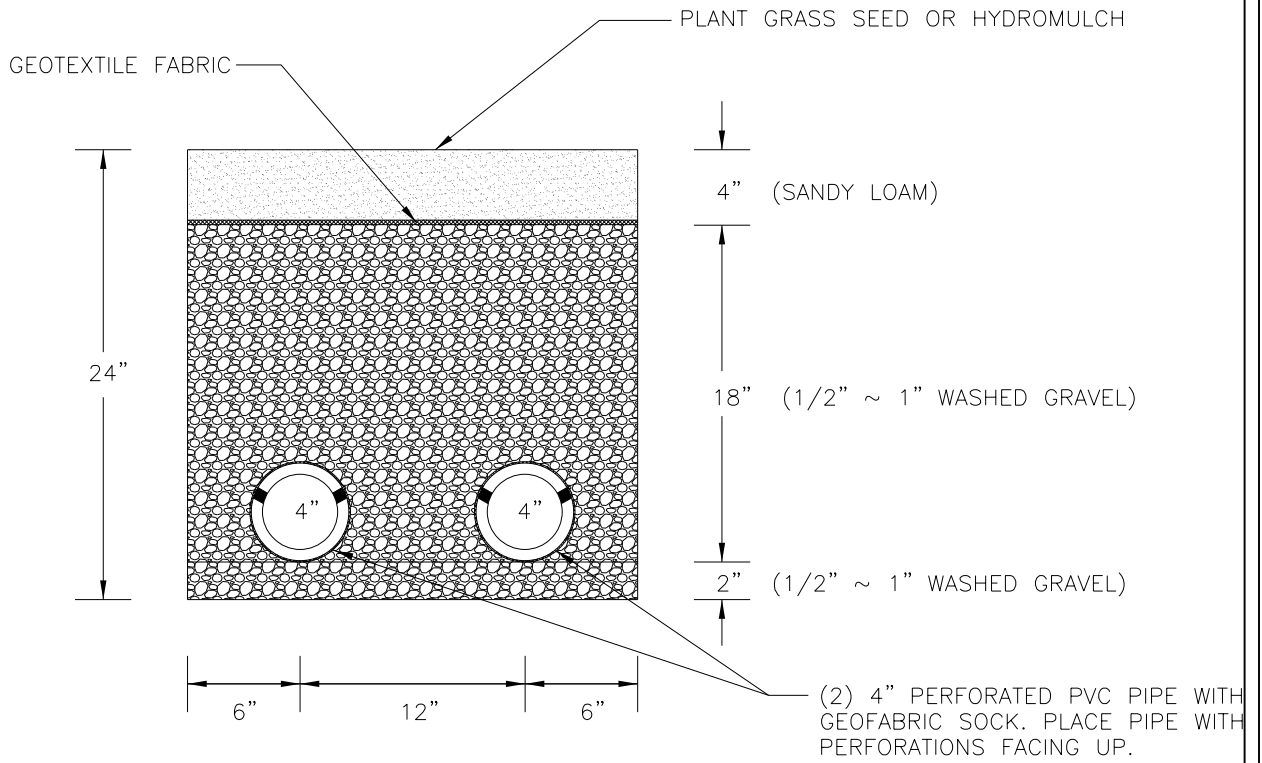

SCALE: NOT TO SCALE



MARBLE FALLS
 800 THIRD STREET
 MARBLE FALLS, TX 78654
 PH: (830) 693-6737

These documents were prepared by,
 or under the supervision of:

ERIC BELAJ 107148 May 31, 2017
 Engineer's Name PE# Date

Eric Belaj
 Engineer's Signature

SECTION
STORM DRAINAGE

DETAIL NO.
 SD-9

TITLE
 FRENCH DRAIN

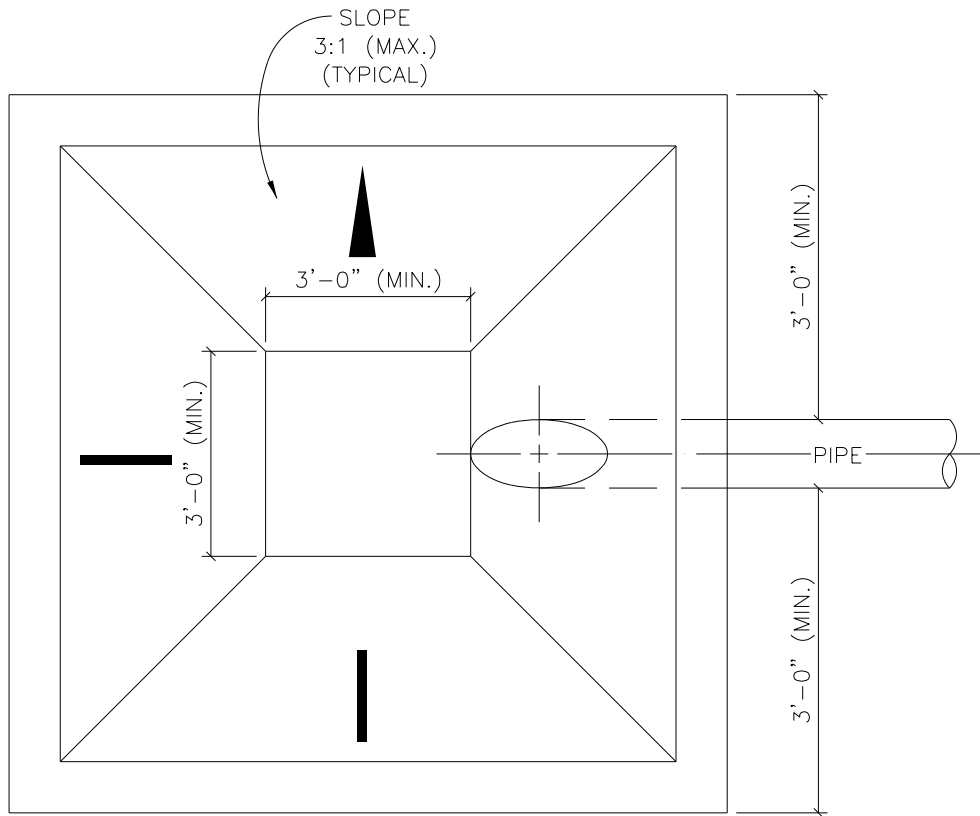

PLAN

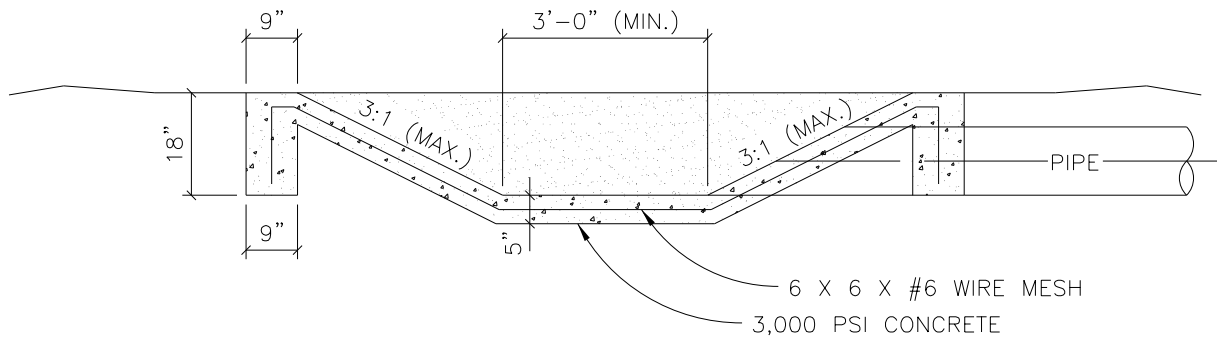

SECTION

SCALE: NOT TO SCALE



MARBLE FALLS
 800 THIRD STREET
 MARBLE FALLS, TX 78654
 PH: (830) 693-6737

These documents were prepared by,
 or under the supervision of:

ERIC BELAJ 107148 May 31, 2017
 Engineer's Name PE# Date

[Signature]
 Engineer's Signature

SECTION
STORM DRAINAGE

DETAIL NO.
 SD-10

TITLE
 CONCRETE VALLEY DRAIN

MINIMUM RIP-RAP QUANTITIES	
PIPE	SQ. YDS.
18"	6.2
24"	6.9
27"	7.8
30"	9.5
36"	10.4
42"	12.0
48"	14.3
54"	16.4

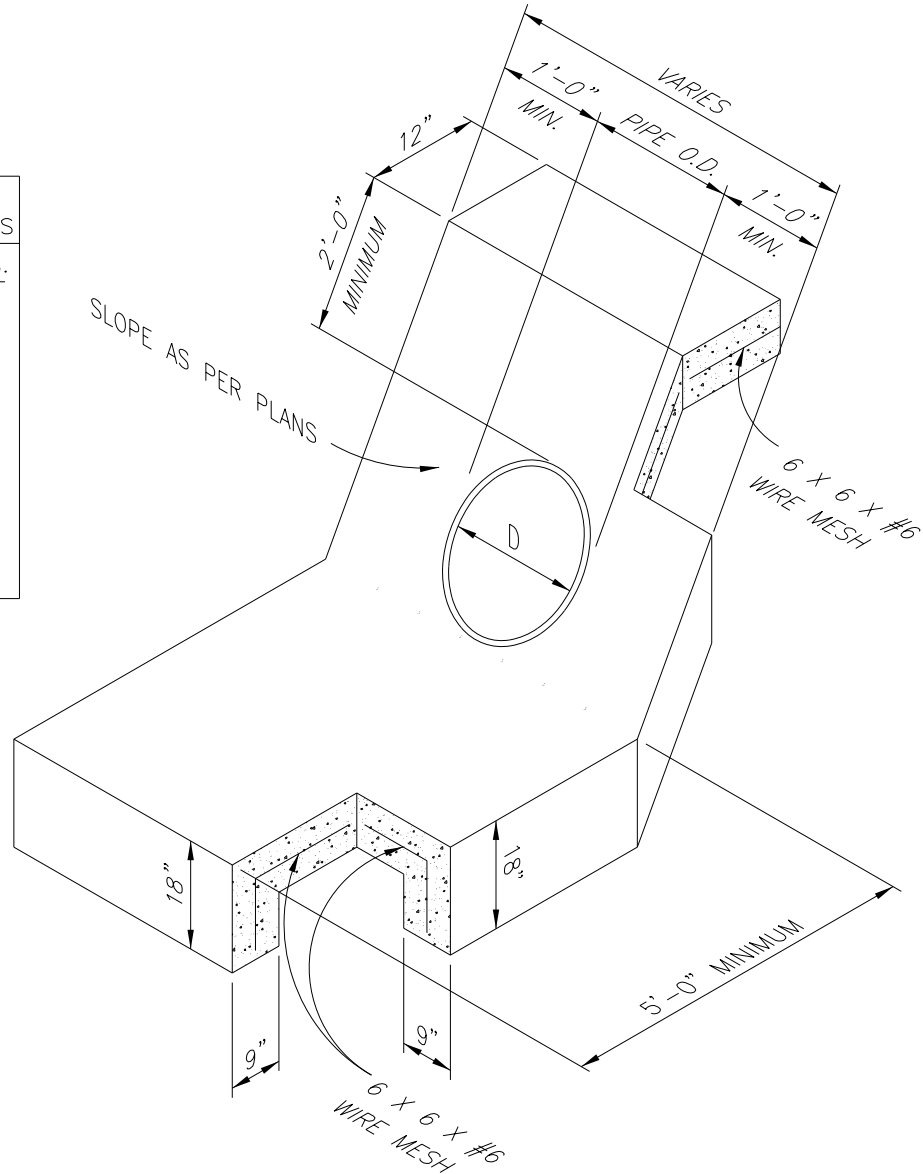

NOTES:

1. WHEN HEADWALLS AND WINGWALLS ARE REQUIRED, THEY SHALL CONFORM TO THE TxDOT STANDARDS, OR AS DIRECTED BY THE CITY.
2. ENERGY DISAPPATORS IF PIPE VELOCITY EXCESSED 5.0 F.P.S. OR AS DIRECTED BY THE CITY.

SCALE: NOT TO SCALE



MARBLE FALLS
800 THIRD STREET
MARBLE FALLS, TX 78654
PH: (830) 693-6737

These documents were prepared by,
or under the supervision of:

ERIC BELAJ 107148 May 31, 2017
Engineer's Name PE# Date

Engineer's Signature

SECTION

STORM DRAINAGE

DETAIL NO.

SD-11

TITLE

SLOPED END TREATMENT
TYPE 'A'

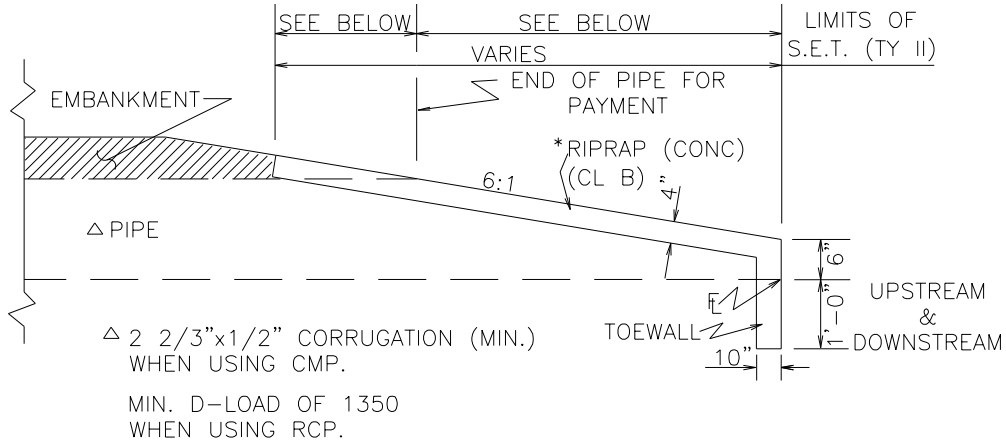

TYPICAL SECTION

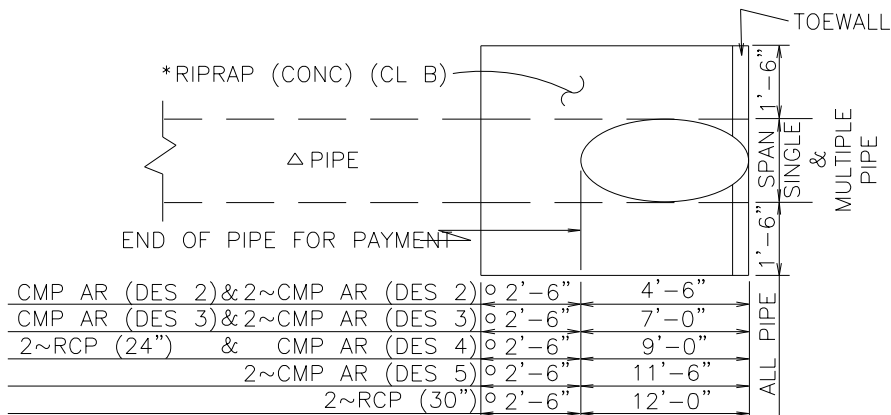

EST. RIPRAP QUAN. FOR ONE SAFETY END TREATMENT (FOR INFORMATION ONLY.)
 CMP AR (DES 2) = 0.5 CY
 CMP AR (DES 3) = 0.7 CY
 CMP AR (DES 4) = 0.8 CY
 2~CMP AR (DES 2) = 0.8 CY
 2~CMP AR (DES 3) = 1.2 CY
 2~CMP AR (DES 5) = 2.2 CY
 2~RCP (24") = 0.8 CY
 2~RCP (30") = 1.2 CY

°MAY VARY TO SUIT CONDITIONS.

TYPICAL PLAN

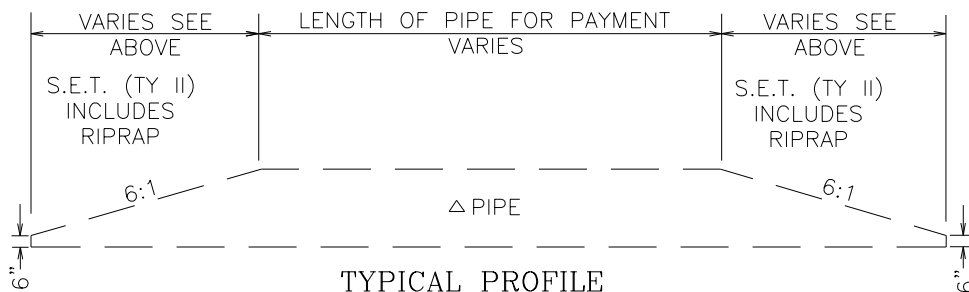

TYPICAL PROFILE

SCALE: NOT TO SCALE



MARBLE FALLS
 800 THIRD STREET
 MARBLE FALLS, TX 78654
 PH: (830) 693-6737

These documents were prepared by,
 or under the supervision of:

ERIC BELAJ 107148 May 31, 2017
 Engineer's Name PE# Date

[Signature]
 Engineer's Signature

SECTION
STORM DRAINAGE

DETAIL NO.
 SD-12

TITLE
 SLOPED END TREATMENT
 TYPE 'B' (1 OF 2)

NOTE:

Use same dimensions for multiple pipe.

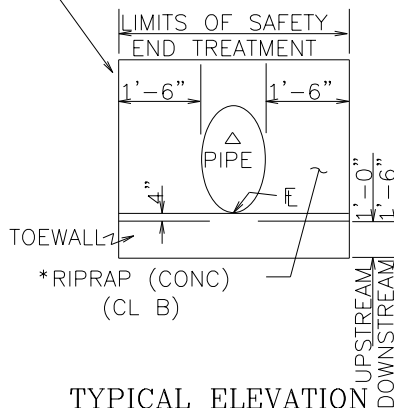

TYPICAL ELEVATION AT PIPE ENDS

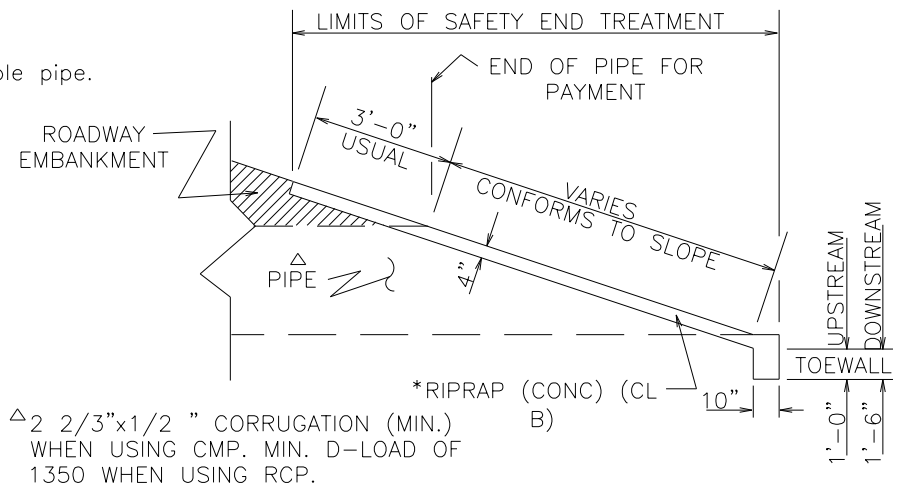

TYPICAL SECTION AT PIPE END

Δ 2 2/3"x1/2" CORRUGATION (MIN.)
WHEN USING CMP. MIN. D-LOAD OF 1350 WHEN USING RCP.

CROSS DRAINAGE SAFETY END TREATMENT (TY II) DETAIL

NOTE:

- PIPE ENDS SHALL BE CUT IN THE FIELD TO MATCH THE ROADWAY SLOPE.
- *ALL RIPRAP CONCRETE SHOWN WITH THE S.E.T. WILL NOT BE PAID FOR DIRECTLY BUT SHALL BE CONSIDERED SUBSIDIARY TO THE BID ITEM "SAFETY END TREATMENT".
- **ALL RIPRAP (CONC) (CL B) PLACED OUTSIDE THE S.E.T. LIMITS (DITCH BLOCK, ETC.) WILL BE PAID FOR IN ACCORDANCE WITH THE BID ITEM "RIPRAP".

IF IN THE OPINION OF THE ENGINEER THAT A DITCH BLOCK IS NEEDED, 100 LF OF MBGF AND 2 TAS WILL BE PLACED AT THE LOCATION DETERMINED BY THE ENGINEER.

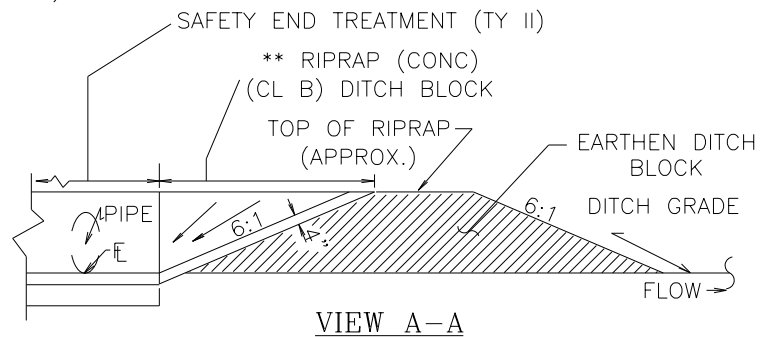
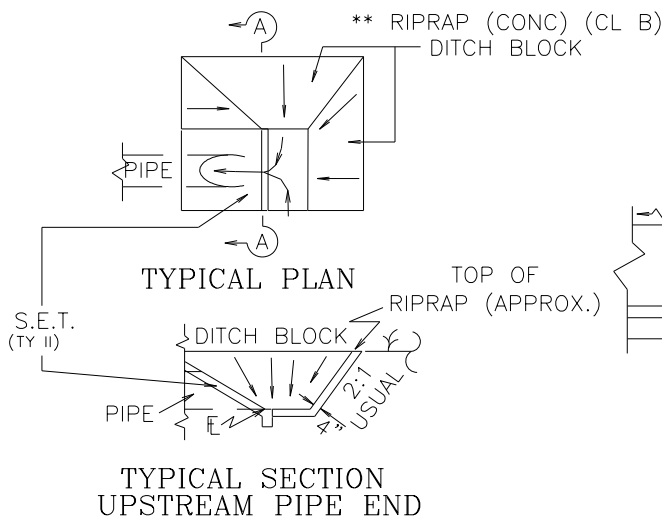

SCALE: NOT TO SCALE



MARBLE FALLS
800 THIRD STREET
MARBLE FALLS, TX 78654
PH: (830) 693-6737

These documents were prepared by,
or under the supervision of:

ERIC BELAJ 107148 May 31, 2017
Engineer's Name PE# Date

[Signature]
Engineer's Signature

SECTION
STORM DRAINAGE

DETAIL NO.
SD-13

TITLE
SLOPED END TREATMENT
TYPE 'B' (2 OF 2)

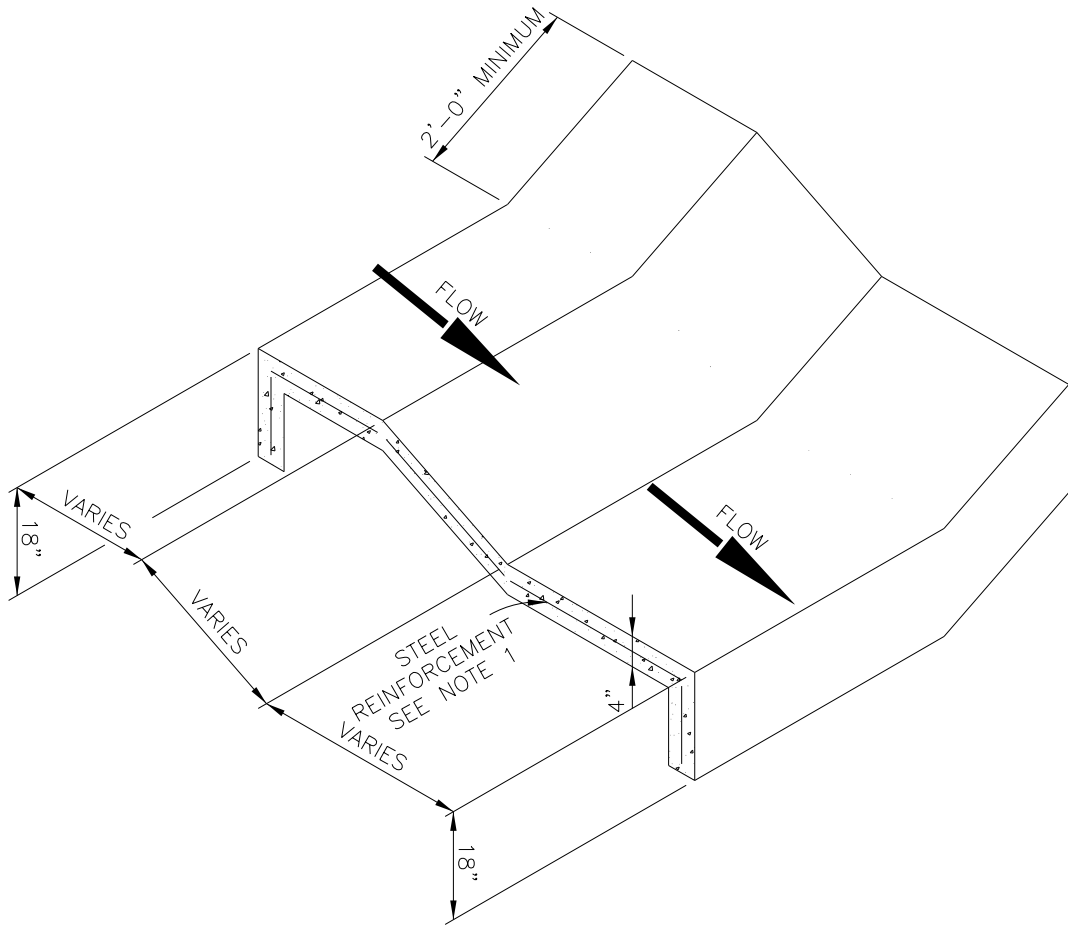

NOTE:

1. CONCRETE RIP RAP SHALL BE REINFORCED WITH #3 BARS, GRADE 60, AT 12" C.C. EACHWAY OR EQUIVALENT WELDED WIRE MESH.

SCALE: NOT TO SCALE



MARBLE FALLS

800 THIRD STREET
MARBLE FALLS, TX 78654

PH: (830) 693-6737

These documents were prepared by,
or under the supervision of:

ERIC BELAJ 107148 May 31, 2017
Engineer's Name PE# Date

Engineer's Signature

SECTION

STORM DRAINAGE

DETAIL NO.

SD-14

TITLE

SPILLWAY TREATMENT

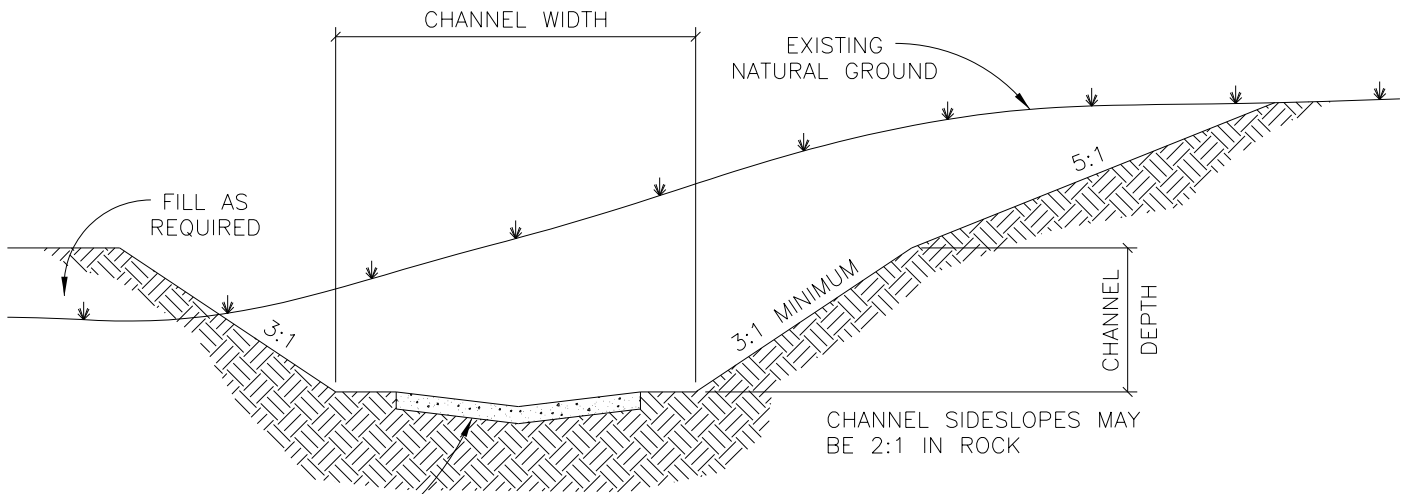

TYPICAL 6 FOOT WIDE
 CONCRETE PILOT CHANNEL
 WITH 6x6x#6 WIRE MESH
 (3000 PSI CONCRETE)

SCALE: NOT TO SCALE



MARBLE FALLS
 800 THIRD STREET
 MARBLE FALLS, TX 78654
 PH: (830) 693-6737

These documents were prepared by,
 or under the supervision of:

ERIC BELAJ 107148 May 31, 2017
 Engineer's Name PE# Date

Engineer's Signature

SECTION
STORM DRAINAGE

DETAIL NO.
 SD-15

TITLE
 PILOT CHANNEL

PIPE OUTLET TO WELL DEFINED CHANNEL

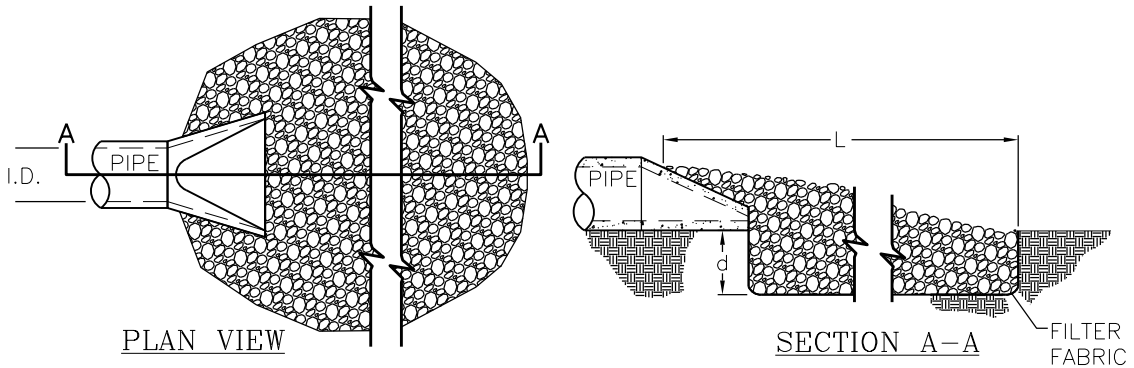

PIPE OUTLET TO FLAT AREA

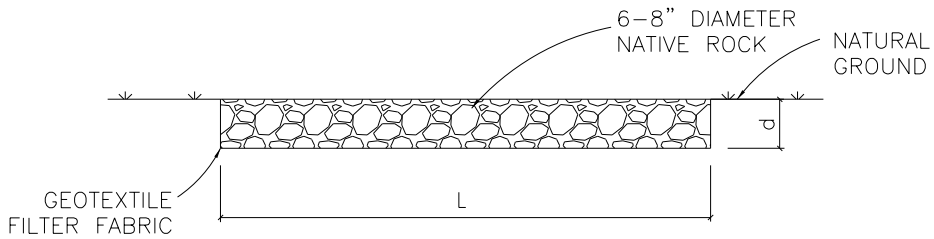
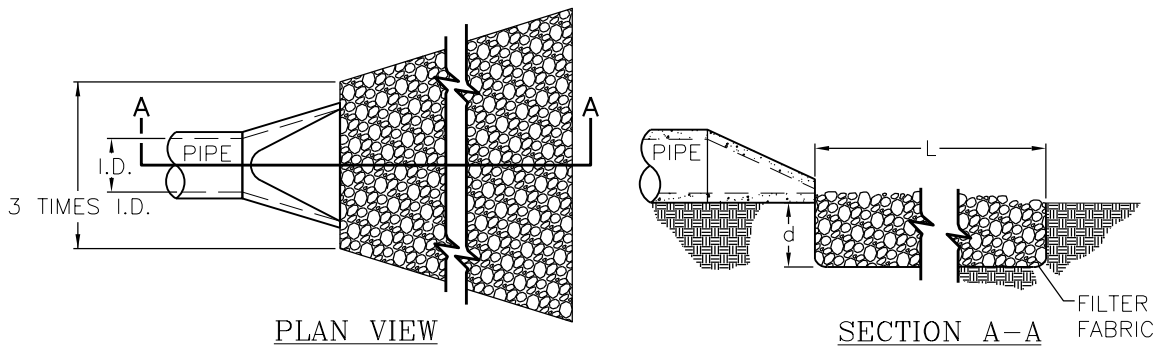

NOTES:

1. L = THE LENGTH OF THE RIPRAP APRON (FT). ($L=0.5V * D$)
 V = CULVERT DISCHARGE VELOCITY (FT/S).
 D = DIAMETER OR HEIGHT OF CULVERT (FT).
2. d = 1.5 TIMES THE MAXIMUM STONE DIAMETER BUT NOT LESS THAN 6" (inches).
3. IN A WELL-DEFINED CHANNEL EXTEND THE APRON UP THE CHANNEL BANKS.
4. A FILTER BLANKET OR FILTER FABRIC SHOULD BE INSTALLED BETWEEN THE RIPRAP AND SOIL FOUNDATION.
5. STONES SHALL BE FIELD STONE OR ROUGH QUARRY STONE, THE STONE SHOULD BE HIGHLY WEATHER RESISTANT, HARD, ANGULAR & WELL GRADED.

SCALE: NOT TO SCALE



MARBLE FALLS
 800 THIRD STREET
 MARBLE FALLS, TX 78654
 PH: (830) 693-6737

These documents were prepared by,
or under the supervision of:

ERIC BELAJ 107148 May 31, 2017
 Engineer's Name PE# Date

Engineer's Signature

SECTION
STORM DRAINAGE

DETAIL NO.
SD-16

TITLE
HEADWALL RIPRAP

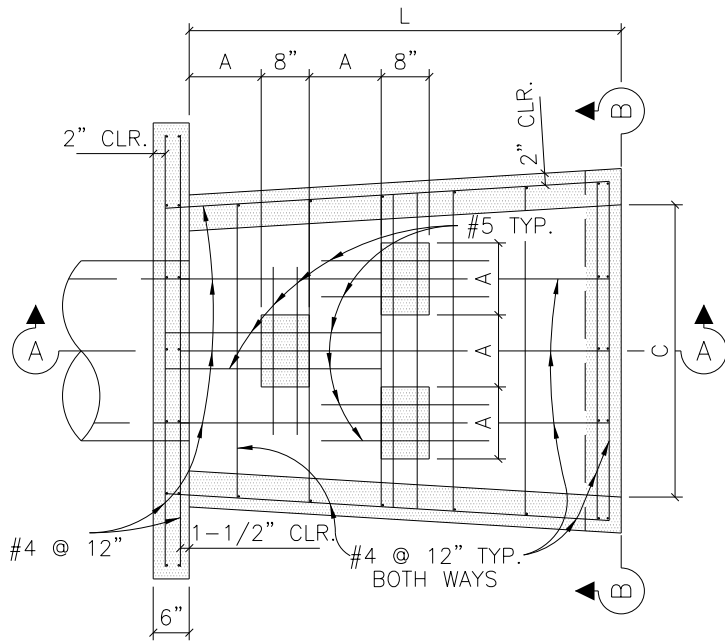

PLAN

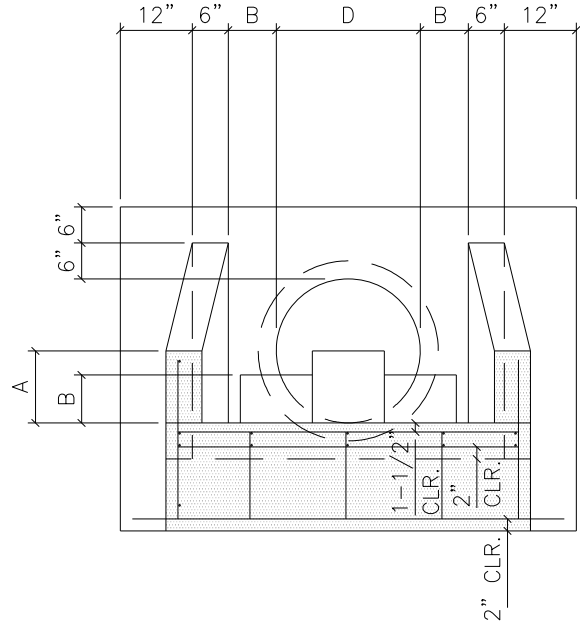

SECTION B-B

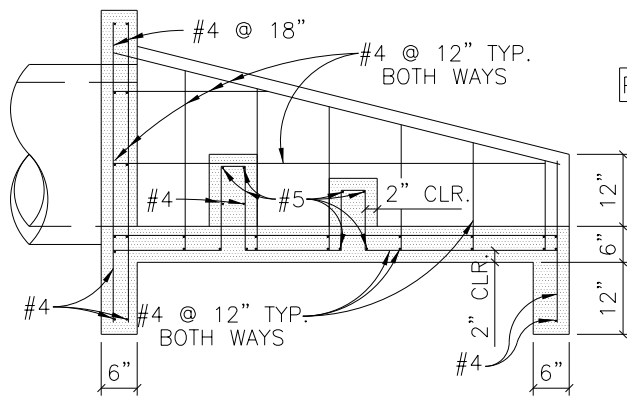

SECTION A-A

DIMENSIONS IN INCHES

PIPE I.D.	18	21	24	27	30	33	36	42	48	54	60
A	9	10	12	14	15	16	18	21	24	27	30
B	6	7	8	9	10	11	12	14	16	18	20
C	32	42	48	54	60	66	72	84	96	108	120
L	54	63	72	81	90	99	108	126	144	162	180

SCALE: NOT TO SCALE



MARBLE FALLS
800 THIRD STREET
MARBLE FALLS, TX 78654
PH: (830) 693-6737

These documents were prepared by,
or under the supervision of:

ERIC BELAJ 107148 May 31, 2017
Engineer's Name PE# Date

Engineer's Signature

SECTION
STORM DRAINAGE

DETAIL NO.
SD-17

TITLE
HEADWALL ENERGY
DISSIPATORS

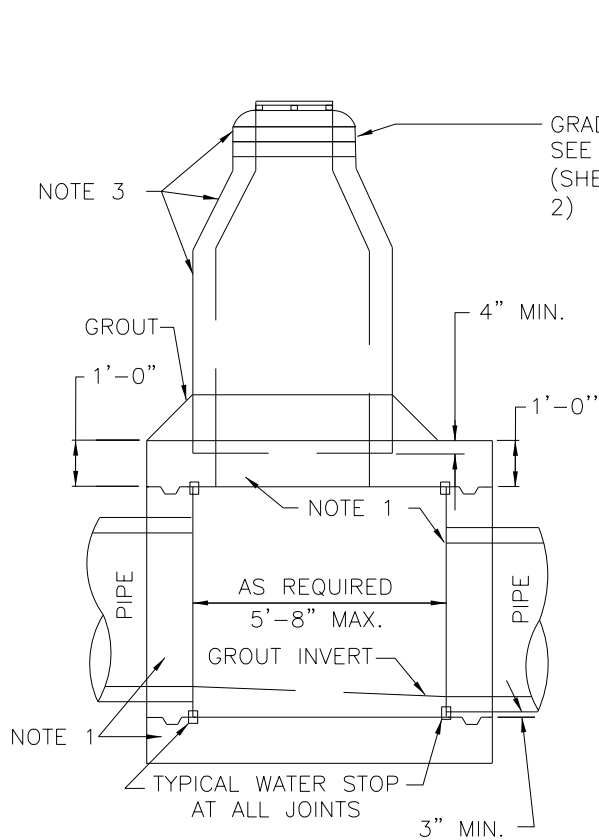

SECTION A-A

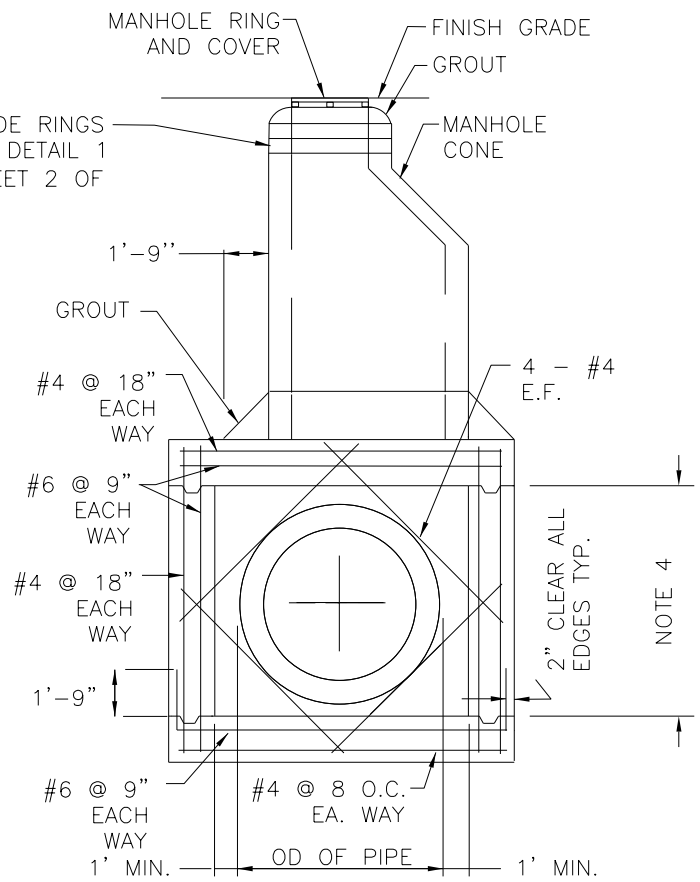

SECTION B-B

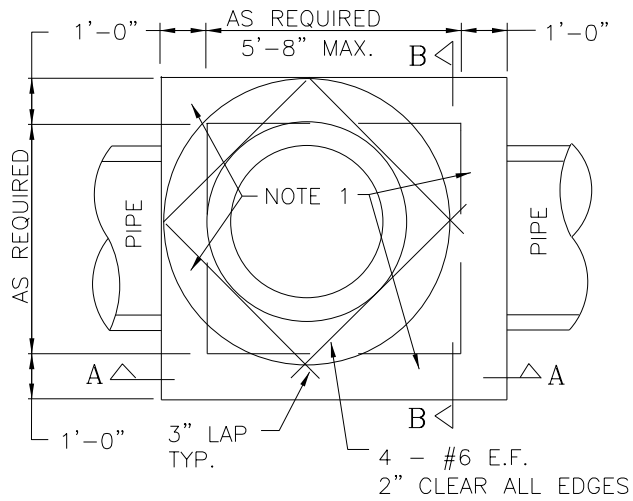

NOTES:

1. ALL CONCRETE SHALL BE CLASS "A" WITH GRADE 8 AGGREGATE.
2. ALL REINFORCEMENT SHALL BE GRADE 60 DEFORMED BARS.
3. IN SHALLOW INSTALLATION WHERE THERE IS INSUFFICIENT DEPTH FOR MANHOLE CONES AND RINGS, SET GRADE RING DIRECTLY ON TOP OF BOX STRUCTURE
4. CONSTRUCT BOX AT DEPTHS AND WITH VERTICAL CLEARANCE AS REQUIRED TO ACCOMMODATE ALL PIPE CONNECTIONS.
5. USE THE CITY OF MARBLE FALLS STANDARD STORM SEWER SET. STORM SEWER MANHOLE FRAMES AND COVER TO BE EAST JORDAN IRON WORKS, INC. V-1600-5 OR APPROVED EQUAL (24" OR 38")

SCALE: NOT TO SCALE



MARBLE FALLS
800 THIRD STREET
MARBLE FALLS, TX 78654
PH: (830) 693-6737

These documents were prepared by,
or under the supervision of:

ERIC BELAJ 107148 May 31, 2017
Engineer's Name PE# Date

[Signature]
Engineer's Signature

SECTION
STORM DRAINAGE

DETAIL NO.
SD-18

TITLE
JUNCTION BOX
(1 OF 2)

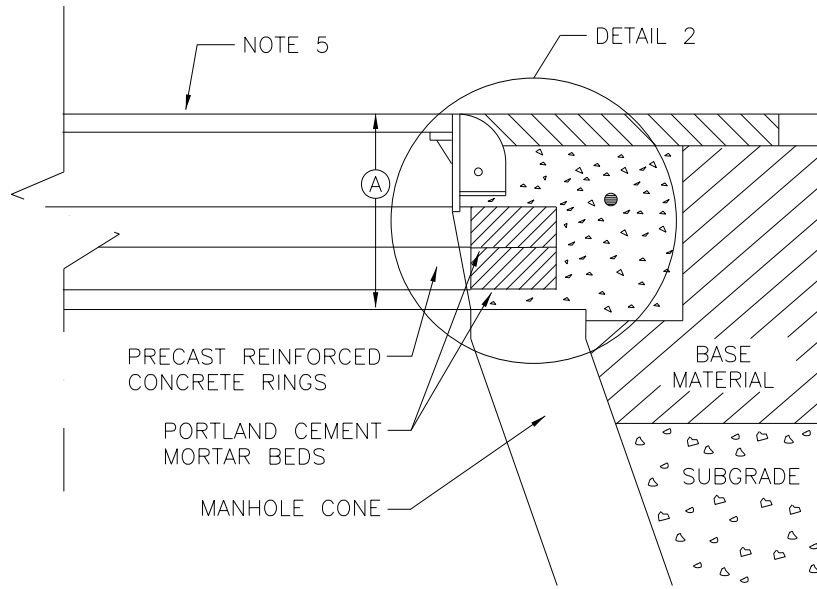

DETAIL 1

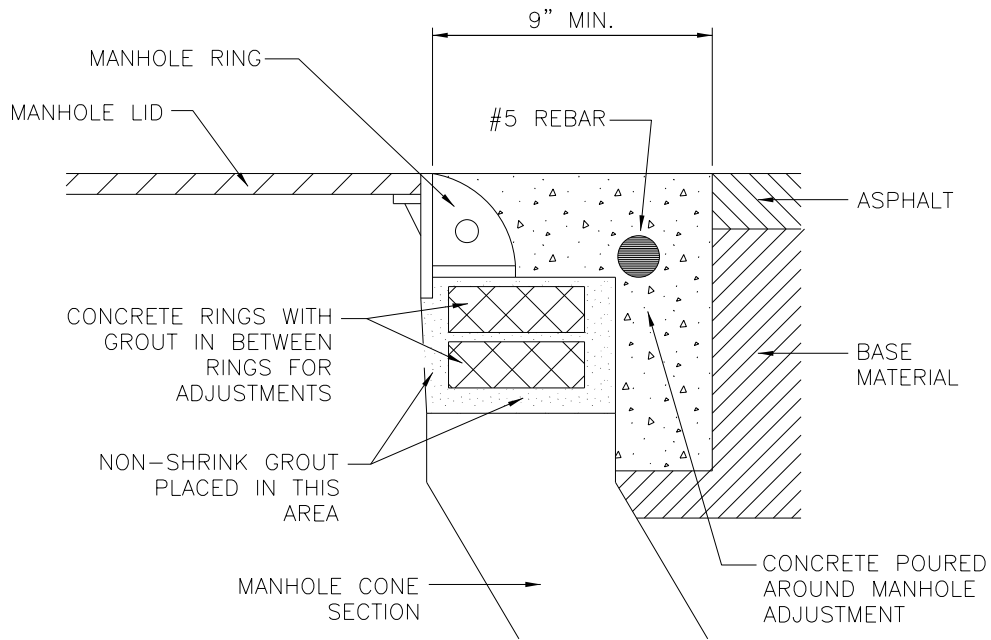

DETAIL 2

SCALE: NOT TO SCALE



MARBLE FALLS
 800 THIRD STREET
 MARBLE FALLS, TX 78654
 PH: (830) 693-6737

These documents were prepared by,
 or under the supervision of:

ERIC BELAJ 107148 May 31, 2017
 Engineer's Name PE# Date

[Handwritten Signature]
 Engineer's Signature

SECTION
STORM DRAINAGE

DETAIL NO.
 SD-19

TITLE
 JUNCTION BOX
 (2 OF 2)

MAST ARM = *A (TYP.)

NOTES:

1. DRILLED SHAFT FOOTING- USE CLASS "C" CONCRETE. VISIBLE PORTION OF CONCRETE TO RECEIVE RUBBED FINISH.
2. FOUR GALVANIZED STEEL ANCHOR BOLTS (MIN. YIELD = 55 KSI) *F(DIA.) X *G(LENGTH) WITH *H HOOKS AT BOTTOM. BOLTS SHALL BE ACCORDING TO POLE MANUFACTURER'S SPECIFICATIONS AND INSTALLED WITH POLE MANUFACTURER'S TEMPLATE.
3. ONE SCH. 40 PVC CONDUIT SIZED AS REQUIRED FOR PULLING WIRE. CONDUIT SHALL BE ROUTED FROM POLE TO PULL BOX AS REQUIRED.
4. ONE 3/8" COPPER GROUND ROD. POLE AND SYSTEM TO BE CONNECTED TO GROUND ROD AT INSTALLATION OF POLE.
5. EIGHT BARS #4 EVENLY SPACED, MAINTAIN MIN. 3" CLEAR.
6. SPIRAL 3/8" DIA. AT 12" PITCH, MAINTAIN MIN. 3" CLEAR.
7. ALL LUMINARIES AND POLES SHALL INCLUDE ALL REQUIRED MISCELLANEOUS PARTS, FITTINGS, WIRING, FUSES, AND LAMPS REQUIRED TO PRODUCE A FULLY FUNCTIONING SYSTEM.

POLE HEIGHT = *B (TYP.)

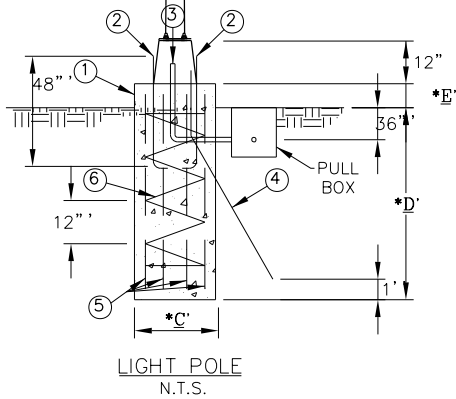

*** DIMENSIONS**

LOCATION		
A		FT.
B		FT.
C		IN.
D		FT.
E		IN.
F		IN.
G		IN.
H		IN.

* DIMENSIONS AND REINFORCING SCHEDULE IS SPECIFIC TO EACH USE. APPROPRIATE DESIGN MUST BE PROVIDED BY DESIGN ENGINEER.

Install conduit and trench in accordance with the National Electric Code (NEC)

SCALE: NOT TO SCALE



MARBLE FALLS
 800 THIRD STREET
 MARBLE FALLS, TX 78654
 PH: (830) 693-6737

These documents were prepared by,
 or under the supervision of:

ERIC BELAJ 107148 May 31, 2017
 Engineer's Name PE# Date

Engineer's Signature

SECTION

ELECTRICAL

DETAIL NO.

EL-1

TITLE

STREET LIGHT

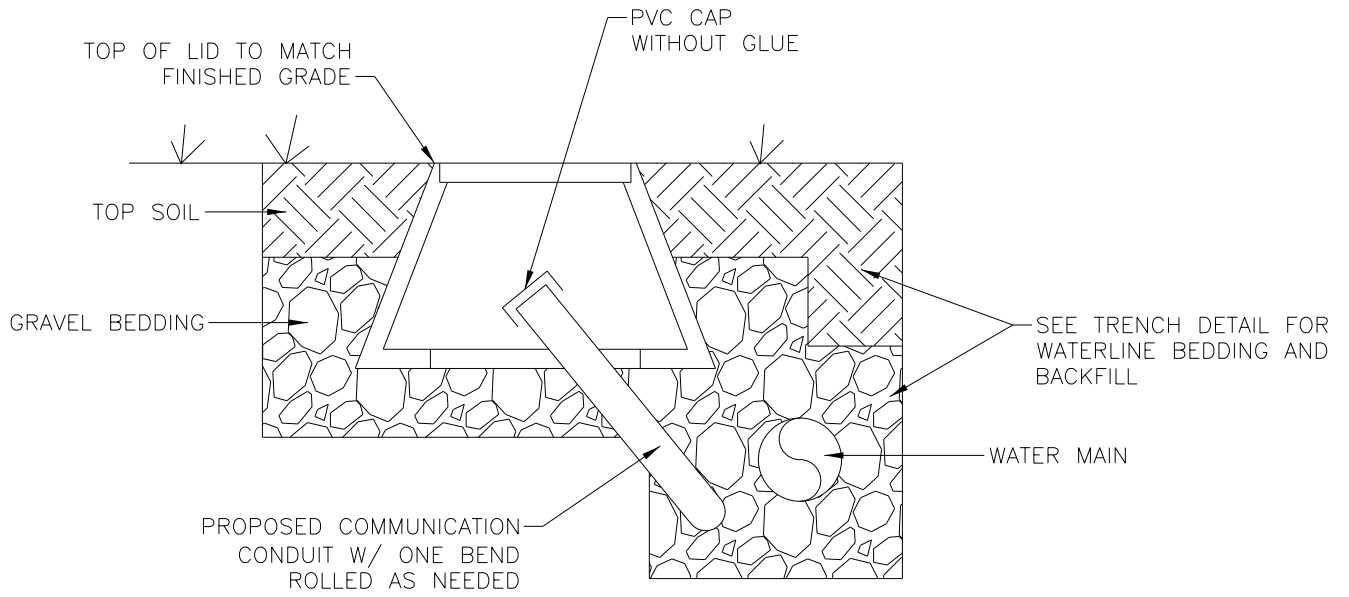

END VIEW - CONDUIT IN WATER LINE TRENCH

N.T.S.

SCALE: NOT TO SCALE



MARBLE FALLS

800 THIRD STREET
MARBLE FALLS, TX 78654

PH: (830) 693-6737

These documents were prepared by,
or under the supervision of:

ERIC BELAJ 107148 May 31, 2017
Engineer's Name PE# Date

Engineer's Signature

SECTION

ELECTRICAL

DETAIL NO.

EL-3

TITLE

ELECTRICAL & COMM.
PULL BOX (2 OF 2)

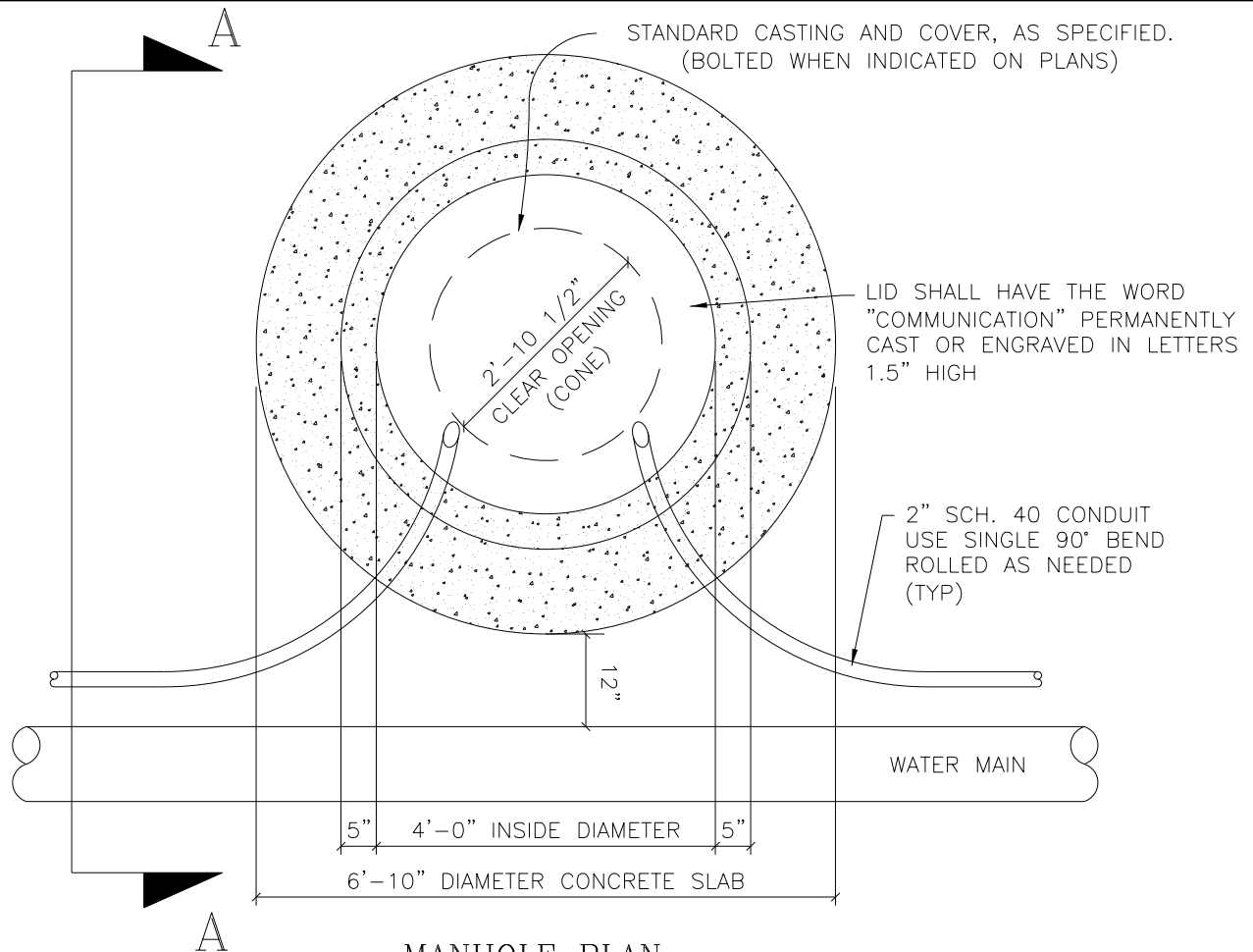

MANHOLE PLAN

NOTES:

MANHOLE DETAILS SHALL REFLECT THE CITY'S MINIMUM SPECIFICATIONS, AS STATED BELOW:

1. ALL MANHOLES SHALL BE 48" I.D., R.C.P., CLASS III, WITH RUBBER O-RING GASKET JOINTS CONFORMING TO ASTM C478, C433 AND C76.
2. ALL MANHOLES SHALL HAVE WATER-TIGHT FRAME AND COVER, WITH A MINIMUM 30" CLEAR OPENING, AS MANUFACTURED BY EAST JORDAN IRON WORKS (AS PER CONCRETE APRON AROUND MANHOLE RING & COVER DETAIL) OR APPROVED EQUAL.
3. ALL MANHOLES SHALL BE CONCRETE WITH CAST IRON FRAME AND BOLTED COVER.
4. ALL MANHOLES SHALL HAVE A CONCENTRIC LID.
5. TWO (2") INCH GRADE RINGS WITH AN I.D. TO MATCH FRAMES CLEAR OPENING, MINIMUM OF TWO (2), MAXIMUM OF FIVE (5) GRADE RINGS REQUIRED.
6. MANHOLES SHALL BE PRECAST ASTM C-478 BELL AND SPIGOT WITH "O" RING JOINTS.
7. SEE SPECIFICATIONS ON MATERIALS AND CONSTRUCTION.
8. ALL MANHOLE COVERS SHALL BE BOLTED. MANHOLES LOCATED IN PAVEMENT TO BE DESIGNED FOR HS-20 TRAFFIC LOADS.
9. MANHOLES LOCATED IN PAVEMENT SHALL HAVE BACKFILL COMPACTED TO 95% OF OPTIMUM AS DETERMINED BY TXDOT TEST METHOD TX114E. DENSITY REPORTS SHALL BE PROVIDED TO CITY FOR CERTIFICATION. AS AN ALTERNATIVE FLOWABLE FILL MATERIAL HAVING A STRENGTH F'_c RANGING FROM 300 TO 500 PSI MAY BE USED FOR BACKFILL.
10. SEE CITY OF MARBLE FALLS STANDARD MANHOLE DETAILS FOR DETAILS NOT SHOWN HERE.

SCALE: NOT TO SCALE



MARBLE FALLS

800 THIRD STREET
MARBLE FALLS, TX 78654

PH: (830) 693-6737

These documents were prepared by,
or under the supervision of:

ERIC BELAJ 107148 May 31, 2017
Engineer's Name PE# Date

Engineer's Signature

SECTION

ELECTRICAL

DETAIL NO.

EL-4

TITLE

ELECTRICAL & COMM.
MANHOLE (1 OF 2)

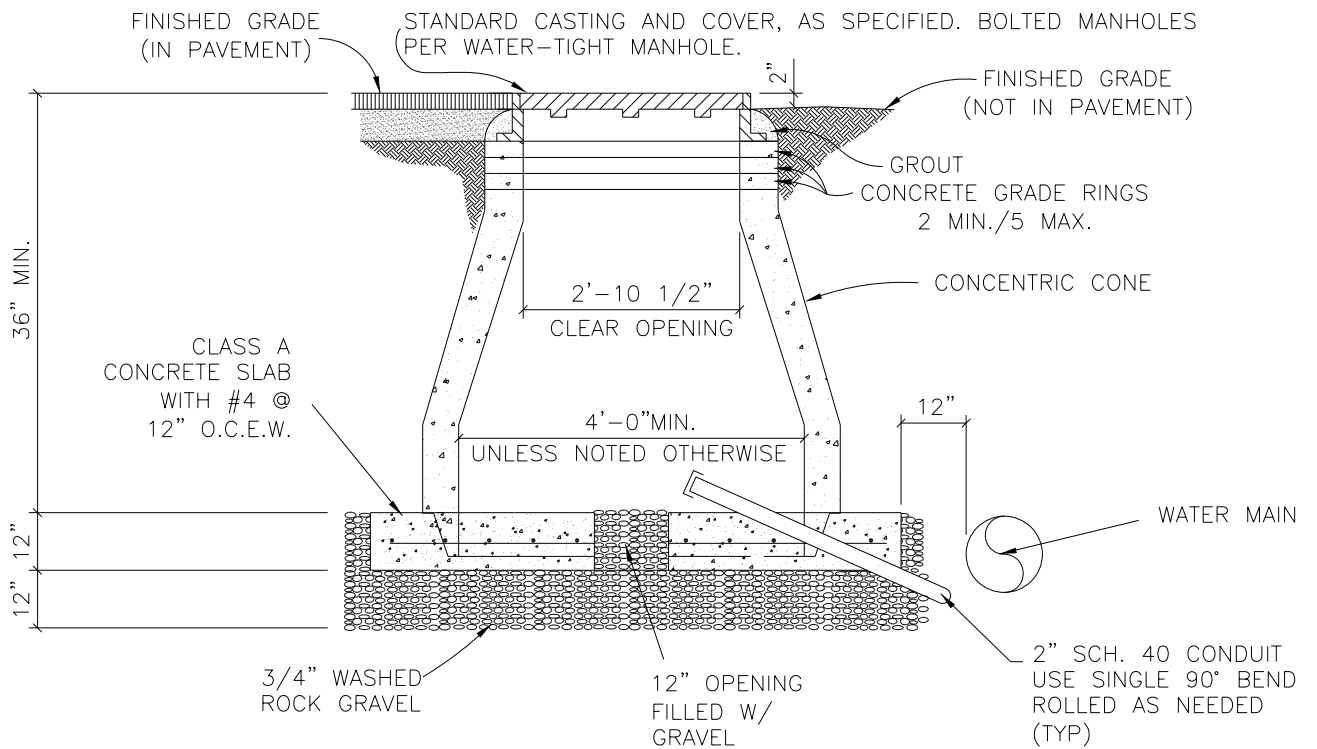

SECTION A-A

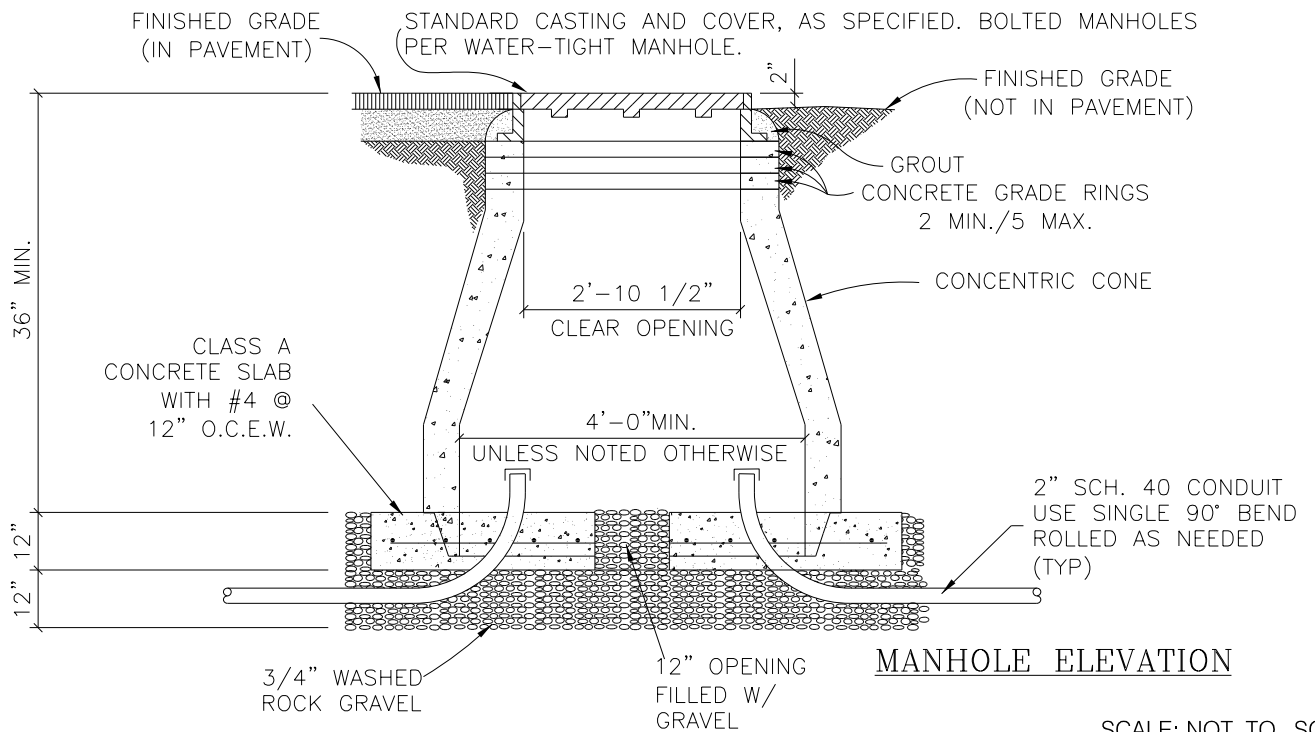

SCALE: NOT TO SCALE



MARBLE FALLS
800 THIRD STREET
MARBLE FALLS, TX 78654
PH: (830) 693-6737

These documents were prepared by,
or under the supervision of:

ERIC BELAJ 107148 May 31, 2017
Engineer's Name PE# Date

Eric Belaj
Engineer's Signature

SECTION

ELECTRICAL

DETAIL NO.

EL-5

TITLE

ELECTRICAL & COMM.
MANHOLE (2 OF 2)